

ME
and
my
Night
systems

MisuraEmme®

*Hands respectful of tradition,
evoke emotions, hands proud of developing
Italian made products.*

*Mani capaci di rispettare la tradizione,
evocare emozioni, mani orgogliose
di produrre Made in Italy.*



ME AND MY NIGHT SYSTEMS

COLLEZIONE ARMADI E CABINE ARMADIO
WARDROBE AND WALK-IN CLOSET COLLECTION

Sommario _ Index

39 PALO ALTO I-BOX	127 PALO ALTO FREE	177 PALO ALTO WALL	221 DESIGN SOLUTIONS	279 DOORS	335 HANDLES	343 EQUIPMENT
60 Dimensioni e componenti struttura _ <i>Dimensions and structure components</i>	138 Dimensioni e componenti struttura _ <i>Dimensions and structure components</i>	196 Dimensioni e componenti struttura _ <i>Dimensions and structure components</i>	224 Angoli esterni, passaggi porta e retro finito _ <i>External corners, doorways and back finished panels</i>	280 Narcisse	337 Roller	344 Organizzazione interni _ <i>Inner unit organization</i>
74 Finiture struttura _ <i>Structure finishings</i>	148 Finiture struttura _ <i>Structure finishings</i>	206 Finiture struttura _ <i>Structure finishings</i>	230 Composizioni lineari _ <i>Linear compositions</i>	286 Zeus	337 Rod	356 Finiture attrezzatura _ <i>Equipment finishings</i>
80 Tipologia aperture _ <i>Opening typologies</i>	152 Tipologia aperture _ <i>Opening typologies</i>	210 Accessori e dettagli struttura _ <i>Accessories and structure details</i>	234 Finestre, passaggi porta e colonne _ <i>Windows, doorways and columns</i>	292 Rex	337 Comma	360 Ripiani _ <i>Shelves</i>
106 Accessori e dettagli struttura _ <i>Accessories and structure details</i>	164 Accessori e dettagli struttura _ <i>Accessories and structure details</i>	214 Impianto illuminazione _ <i>Lighting system</i>	238 Nicchie, tamponamenti e riduzioni _ <i>Niches, fillers and reductions</i>	298 Puzzle	337 Hook	366 Cassettiere _ <i>Chest of drawers</i>
118 Impianto illuminazione _ <i>Lighting system</i>	170 Impianto illuminazione _ <i>Lighting system</i>		246 Divisorio _ <i>Partitioning</i>	304 London	338 N3	388 Elementi sospesi _ <i>Hanging elements</i>
			250 Angoli interni _ <i>Inside corners</i>	310 Milano	338 Lemma	394 Elementi dedicati _ <i>Dedicated elements</i>
			260 Vanity, vani a giorno e contenitori _ <i>Vanity, open compartments and storage units</i>	316 Brillanta	338 Acanto	404 Elementi Hi-tech _ <i>Hi-tech elements</i>
			264 Raccordi e integrazioni _ <i>Fittings and integrations</i>	322 First	339 Revers	412 Elemento ad Isola _ <i>Island element</i>
			270 Ponti, sopralzi e mansarde _ <i>Bridges, overhangs attics</i>	328 Tecno	339 Per	418 Accessori _ <i>Accessories</i>
			274 Cabine _ <i>Walk-in closet</i>		339 Gost	
					339 Ashi	
					339 Split	
					340 Narcisse	
					340 Rex	
					340 Regula	
					340 Flap	
					341 Puzzle	
					341 Key	
					341 Magnetic Key	

PALO ALTO

I-BOX, FREE, WALL

Palo Alto è una famiglia di 3 sistemi caratterizzati ognuno da un focus specifico di applicazione. I sistemi sono in grado d'integrarsi tra loro per offrire le migliori soluzioni progettuali possibili e garantendo composizioni con un'estetica continuativa, fortemente personalizzabile e senza tempo.

Palo Alto is a family of 3 systems each characterized by a specific application focus. The systems are capable of integrating with each other to offer the best possible design solutions and ensuring compositions with a unique highly customizable and timeless aesthetic.

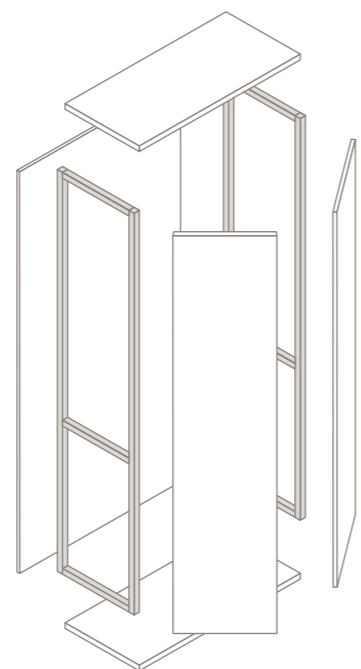

PALO ALTO I-BOX

Un sistema modulare con struttura a box completo, integrabile in ogni suo punto con diversi componenti e accessori come pannelli, ante, mensole, cassetti, ideale per generare configurazioni infinite di armadi e cabine armadio.

A modular system with a box structure, it can be integrated at every point with different components and accessories such as panels, doors, shelves, drawers, ideal for generating endless configurations of closets and walk-in closets.

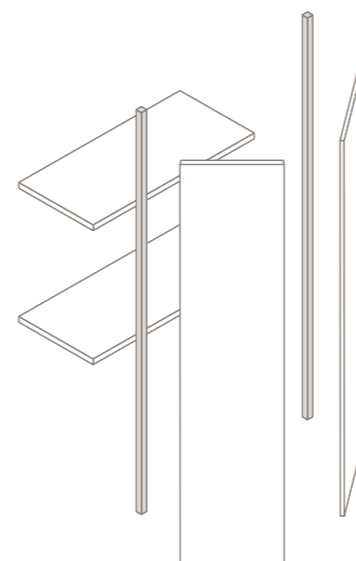

PALO ALTO FREE

Un sistema modulare con una struttura composta da montanti terra-soffitto, sulla quale si innestano direttamente diversi componenti e accessori come ante, mensole e cassetti. Ideale per generare armadi in nicchia o configurazioni a portale anche completamente svincolate dalle pareti.

A modular system with a structure composed of floor-to-ceiling uprights, in which various components and accessories such as doors, shelves and drawers are directly inserted. Ideal for generating niche cabinets or doorways that are also completely disconnected from walls.

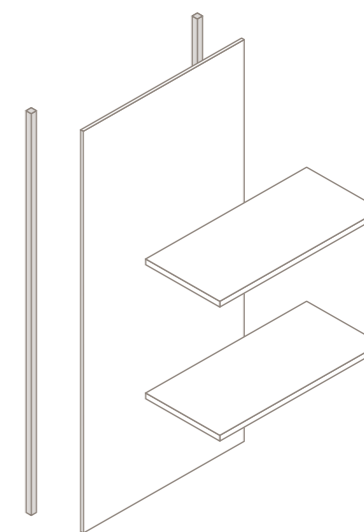

PALO ALTO WALL

Un sistema modulare a boiserie terra-soffitto con la possibilità d'integrare componenti e accessori come mensole, cassetti e contenitori. Ideale per sfruttare e arredare elegantemente le pareti della zona notte soprattutto in configurazioni di cabine armadio.

A modular floor-to-ceiling boiserie system with the possibility of integrating components and accessories such as shelves, drawers and storage units. Ideal for exploiting and elegantly furnishing the walls of the night area especially in walk-in closet configurations.

PALO ALTO ARCHITECTURAL

I-BOX, FREE, WALL

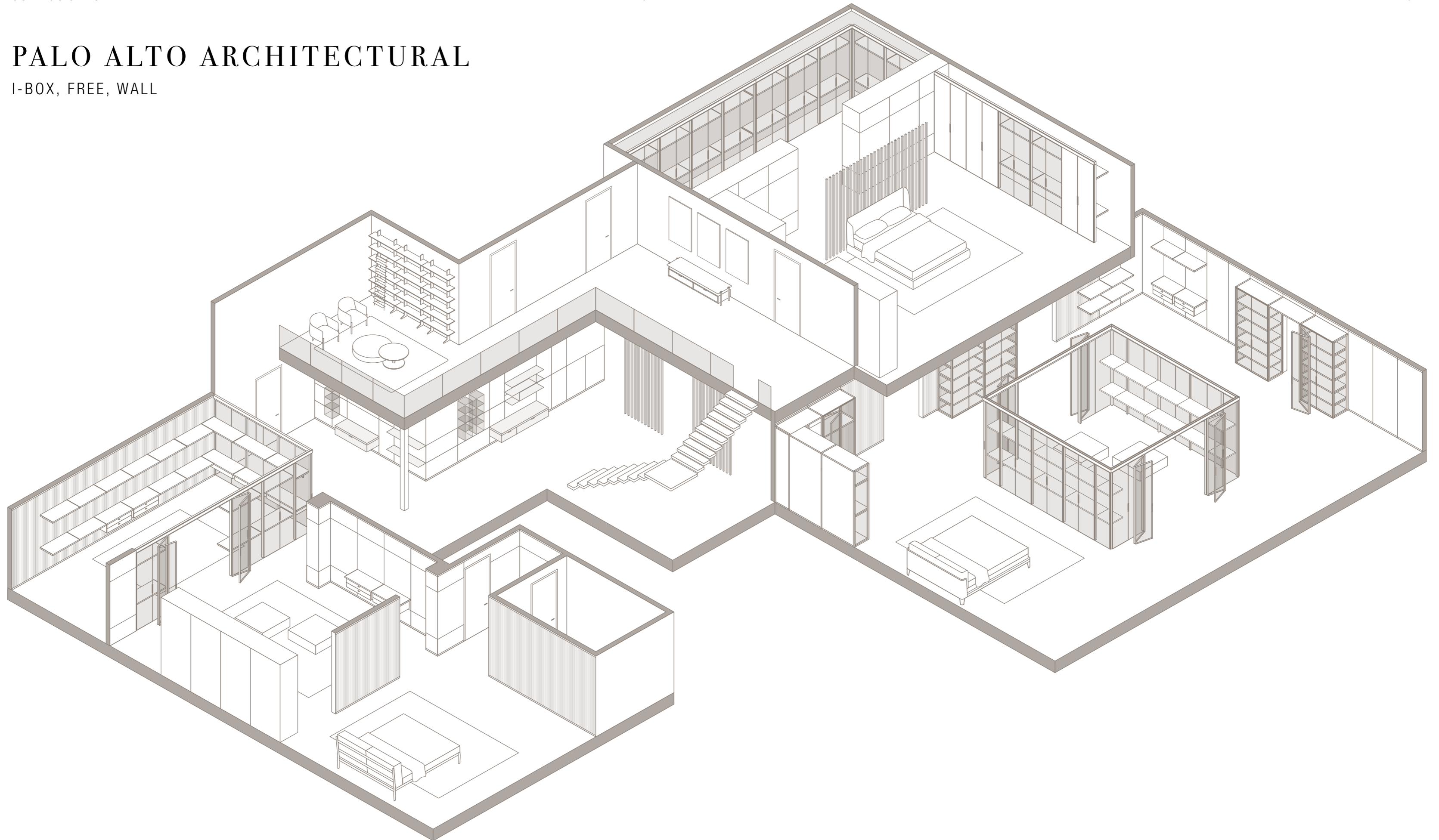





Nelle pagine precedenti:
 Sistema notte **Palo Alto Free**, ante **Rex** apertura "RX6"
 e ripiani **Frame** in vetro trasparente,
 parti in metallo verniciato Canna di Fucile.
 Sistema notte **Palo Alto I-Box**, con ante **Puzzle**
 integrato al sistema **Boiserie Puzzle** in finiture CIMENTO®
 Naturale (cemento) e Paglia Intrecciata. Sistema notte
Palo Alto Wall, pannelli in finitura Paglia Intrecciata,
 ripiani **Frame** in vetro trasparente, cassettiere sospese
 essenza Tabacco, frontali in ecopelle lavorata con
 maniglie **Cardea**, parti in metallo verniciate Canna di Fucile.
 Nella pagina a fianco: Sistema notte **Palo Alto Wall**,
 con pannelli in essenza Millerighe Tabacco, cassettiere
 sospese in ecopelle con top in essenza Tabacco, maniglie
Cardea, ripiani **Frame** in vetro trasparente,
 parti in metallo verniciato Canna di Fucile.

On the previous pages:
Palo Alto Free night system, **Rex** doors with "RX6"
 opening, doors and **Frame** shelves
 in transparent glass, structure in Gunmetal finish.
Palo Alto I-Box night system, with **Puzzle** doors
 integrated with **Puzzle Boiserie** system featuring
 CIMENTO® Natural (concrete) and Woven Straw finishes.
Palo Alto Wall night system in Woven Straw finish,
 with transparent glass **Frame** shelves, hanging chest of
 drawers units, top in Tobacco veneer, eco-leather fronts
 and **Cardea** handles, with Gunmetal varnished frame.
On the side page: Palo Alto Wall night system
 in Tobacco veneer Millerighe finish, with hanging chest
 of drawers units, top in Tobacco essence, eco-leather
 fronts and **Cardea** handles, transparent glass
Frame shelves with Gunmetal varnished frame.





Nella pagina a fianco: dettaglio del sistema notte **Palo Alto Wall** in finitura Millerighe Tabacco, struttura Canna di Fucile, ripiani in vetro trasparente con tubo appendiabiti rivestito in ecopelle.

*On the side page: Detail of **Palo Alto Wall** night system, Tobacco veneer Millerighe finish, Gunmetal varnished frame, transparent glass shelves and hanging rail with eco-leather cover.*

Nella pagina a fianco: **Palo Alto Wall** con cassettera sospesa con frontali in ecopelle lavorata e maglie Cardea, ripiani Frame in vetro trasparente, con tubo appendiabiti rivestito in ecopelle lavorata, parti in metallo verniciate Canna di Fucile.

Nella pagina successiva: Sistema Notte **Palo Alto Wall**, in finitura Paglia Intrecciata con ripiani Portascarpe in vetro trasparente e parti in metallo verniciate Canna di Fucile. Sistema notte **Palo Alto I-Box** con ante **Puzzle** in CIMENTO® Naturale (cemento) e Paglia Intrecciata.

*On the side page: **Palo Alto Wall** night system with hanging chest of drawers, eco-leather fronts and Cardea handles, transparent glass shelves with hanging rail with embossed eco-leather cover.*

*On the next page: **Palo Alto Wall** night system, in Woven Straw finish with transparent glass shoe rack shelves, Gunmetal varnished Frame. **Palo Alto I-Box** night system with **Puzzle** doors in CIMENTO® Natural (concrete) and Woven Straw finishes.*

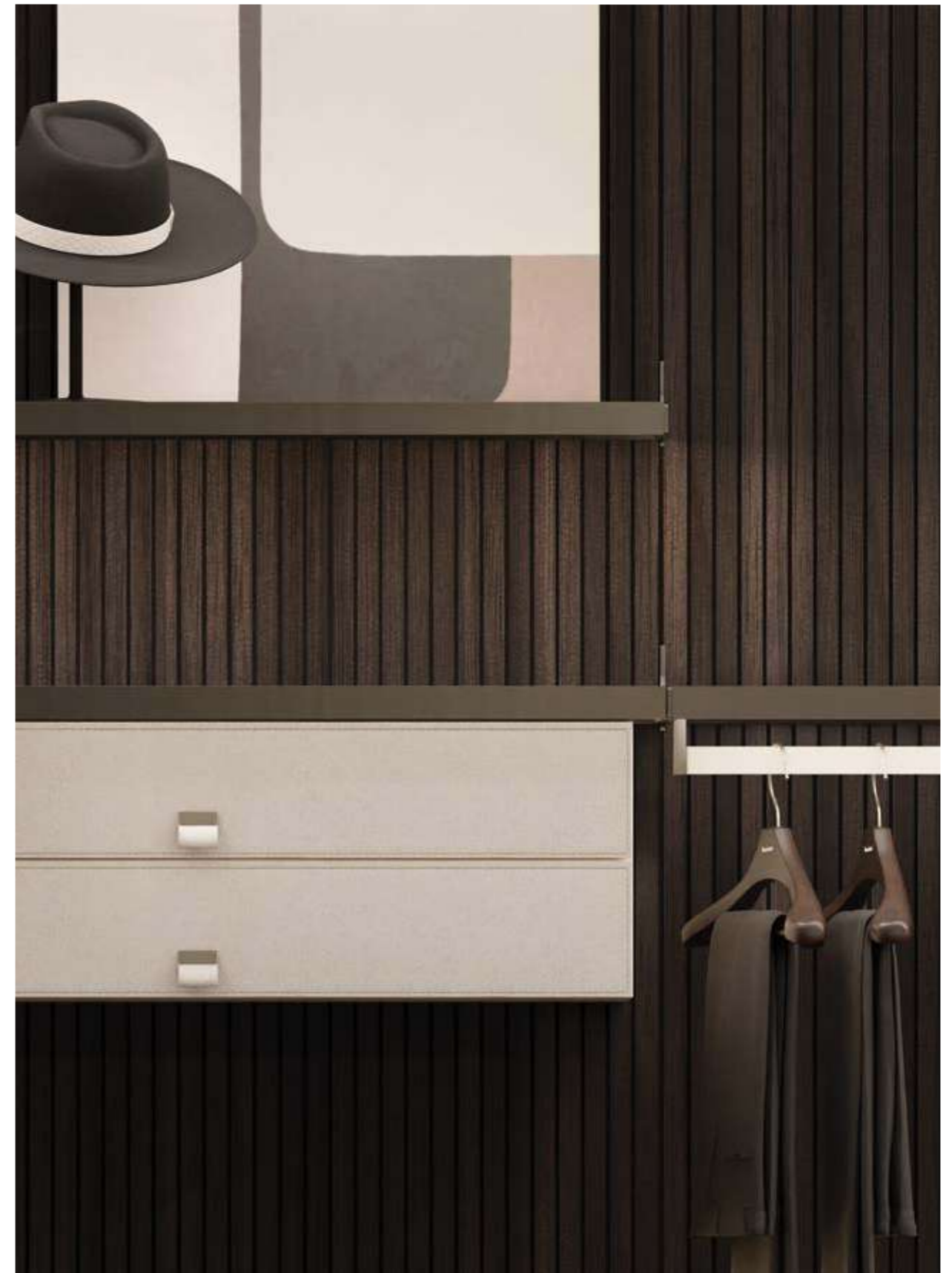







Nella pagina a fianco, nelle pagine precedenti e in quelle successive: Sistema notte **Palo Alto I-Box** con ante Puzzle in CIMENTO® Naturale (cemento) e sistema notte **Palo Alto Free** con struttura in metallo Champagne Silver, ante **Rex** in vetro Trasparente e in essenza Noce Canaletto.

*On the side page, previous pages and next pages: **Palo Alto I-Box** night system with Puzzle doors in CIMENTO® Natural (concrete), **Palo Alto Free** night system with Champagne Silver, **Rex** door in Transparent glass and Canaletto Walnut wood veneer.*



In queste pagine e nelle pagine seguenti: Boiserie **Puzzle** in essenza Noce Canaletto, **Teke** sospese in vetro trasparente. Sistema notte **Palo Alto Free** con ante **Rex** in vetro naturale acidato, struttura in metallo Champagne Silver. Chaise Lounge **Baltimora** struttura metallo, seduta e retro con rivestimento in pelle. Servomuto **Irving**, struttura metallo, piano in marmo. Portagiornali **Denver**, struttura metallo, rivestimento in pelle.

*On these and next pages: **Puzzle boiserie** in Canaletto Walnut veneer with hanging cabinet **Teke**, transparent glass. **Palo Alto Free** night system with frosted natural glass **Rex** doors, Champagne Silver metal frame. **Baltimora** chaise lounge, metal structure seat and back upholstered in leather. **Irving** valet stand, metal structure, marble base. **Denver** magazine rack, metal structure leather covered.*







Nella pagina a fianco: dettaglio del sistema notte **Palo Alto Free** con struttura in metallo Champagne Silver, ante **Rex** in vetro naturale acidato.

*On the side page: detail of **Palo Alto Free** system with Champagne Silver metal frame, frosted natural glass **Rex** doors.*

Nelle pagine successive e in quella a fianco:
boiserie Puzzle in essenza Noce Canaletto con **Teke**
 sospese in vetro trasparente e mensole in alluminio.
 Sistema notte **Palo Alto Free** con struttura in metallo
 Champagne Silver, ante **Rex** in vetro Naturale acidato,
 Chaise Lounge **Baltimora** struttura metallo, seduta e
 retro con rivestimento in pelle. Portagiornali **Denver**,
 struttura metallo e rivestimento pelle. Servomuto **Irving**,
 struttura metallo, piano in marmo.

*On these pages: **Palo Alto Free** night system with
 Champagne Silver metal frame, frosted natural glass **Rex**
 doors. **Puzzle boiserie** in Canaletto
 Walnut veneer, with transparent glass
 hanging storage units and aluminum shelves.
Baltimora chaise lounge, metal structure seat
 and back upholstered in leather. **Denver** magazine rack,
 metal structure, leather cover. **Irving** valet stand,
 metal structure, marble base.*

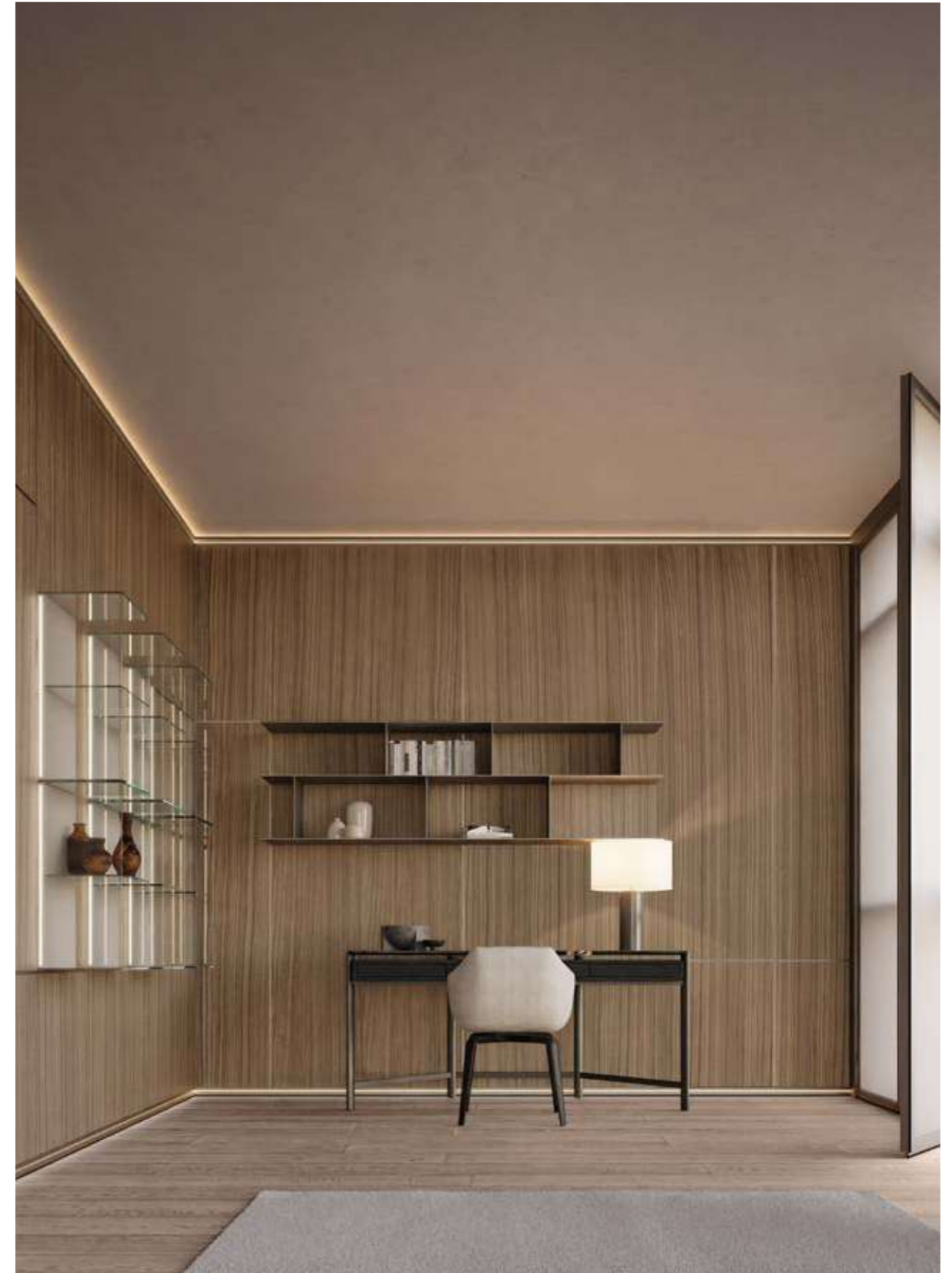



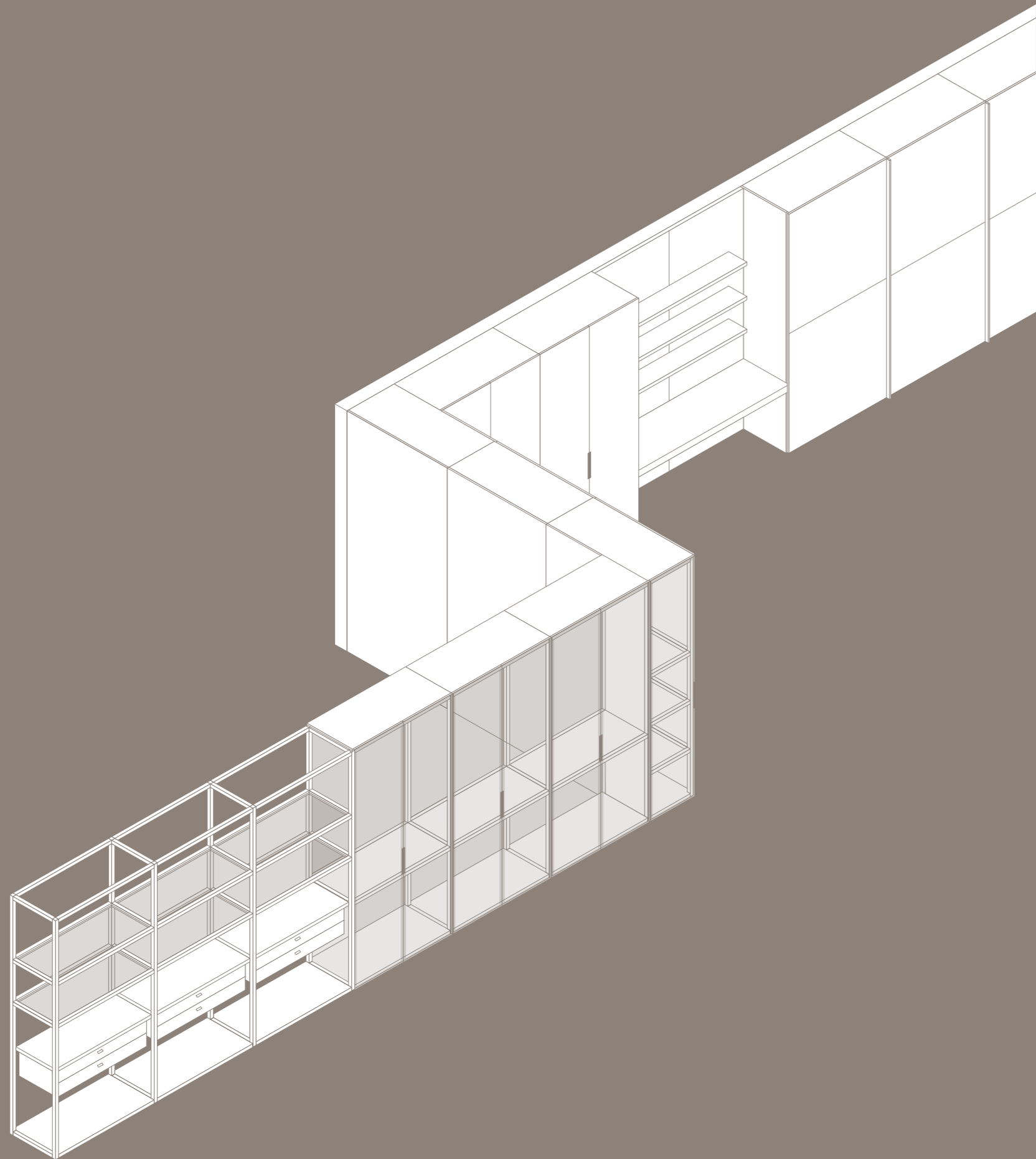

PALO ALTO I-BOX

SISTEMA INTEGRATO CABINA ARMADIO E ARMADIO
 WALK-IN CLOSET AND WARDROBE INTEGRATED SYSTEM

Palo Alto I-Box è un sistema in cui l'armadio e la cabina armadio hanno la medesima struttura, i medesimi elementi, sia in legno che in alluminio, la medesima attrezzatura, le medesime finiture e le medesime regole compositive. Si può quindi dire che nel sistema Palo Alto I-Box l'armadio è una soluzione particolare di cabina armadio completa di ante su ogni modulo e viceversa, la cabina è una soluzione particolare di armadio con assenza di ante. Entrambe le soluzioni sono un sottoinsieme di un sistema che prevede la completa integrazione. È quindi possibile realizzare soluzioni miste con vani senz'ante e con ante di diversa tipologia di apertura.

Precision, pull Palo Alto I-Box System is a system in which the walk-in closet and the wardrobe share the same structures, the same elements, both in wood and in aluminum, the same equipment, the same finishing and last but not least the same compositional rules. Therefore, it is worth asserting that inside Palo Alto I-Box system the wardrobe can be considered as a particular walk-in closet solution supplied with doors on each module and vice-versa, that is the walk-in closet is a particular wardrobe solution without doors. Both solutions represent a subset of a system providing a complete integration. Consequently, it is possible to provide mixed solutions with walk-in closet and with doors characterized by several opening typologies.

60 Dimensioni e componenti struttura _ *Dimensions and structure components*

74 Finiture struttura _ *Structure finishings*

80 Tipologia aperture _ *Opening typologies*

106 Accessori e dettagli struttura _ *Accessories and structure details*

118 Impianto illuminazione _ *Lighting system*





Nelle pagine precedenti e a fianco: sistema notte **Palo Alto I-Box**, fianchi telaio in finitura Canna di Fucile, schienali in Tecnomarble, attrezzatura interna in nobilitato metallizzato Graphite ed ecopelle. Sistema notte **I-Box** con ante **Narcisse** vetro trasparente complanari, fianchi telaio in alluminio finitura Canna di Fucile, schienali tecnomarble Dream Arabesque, scarpiera e attrezzatura interna in nobilitato metallizzato Graphite, ed ecopelle.

*On the previous pages and on the side: **Palo Alto I-Box** night system, framed sides in Gunmetal finish, Tecnomarble backpanel, internal equipment in Graphite metallic melamine and eco-leather. **I-Box** night system, with **Narcisse** transparent glass coplanar doors, sides frame in aluminum finish Gunmetal, back Dream Arabesque tecnomarble, shoe racks and internal equipment in melamine metallic Graphite and eco-leather.*







Nelle pagine precedenti e a fianco: Sistema notte **Palo Alto I-Box**, con ante **Tecno** nobilitato metallizzato Champagne, fianchi telaio in alluminio finitura Canna di Fucile, schienali nobilitato Shantung di Seta, attrezzatura interna in nobilitato metallizzato Champagne.

*On the previous pages and on the side: **Palo Alto I-Box** night system, with **Tecno** doors melamine metallic Champagne, sides frame in aluminum finish Gunmetal, back melamine Silk Shantung, internal equipment in melamine metallic Champagne.*









In queste pagine e in quella successiva: sistema notte **Palo Alto I-Box**, con ante **Rex** essenza Rovere nero e profilo in alluminio finitura Canna di Fucile. Vanity del sistema notte **Palo Alto I-Box**, con boiserie in nobilitato metallizzato Champagne e specchio Fumè, mensola in alluminio in finitura Canna di Fucile, sistema **Maggie** laccato opaco con cassetti in cuoio, scrivania in essenza Rovere nero.

*In these pages and in the following one: **Palo Alto I-Box** night system, with **Rex** doors wooden panel black Oak and aluminum profile finish Gunmetal. Vanity of the **Palo Alto I-Box** night system, with wall panels in melamine metallic Champagne and Fumè mirror, aluminum shelf in Gunmetal finish, matt lacquered **Maggie** system with leather drawers, desk in black Oak wood.*



Dimensioni e componenti struttura _ *Dimensions and structure components*



Dimensioni e componenti struttura _ Dimensions and structure components

DIMENSIONI _ DIMENSIONS

Il sistema Palo Alto I-Box prevede 6 dimensioni in altezza, 2 in profondità e 9 in larghezza.

Palo Alto I-Box provides 6 dimensions in height, 2 in depth and 9 in width.

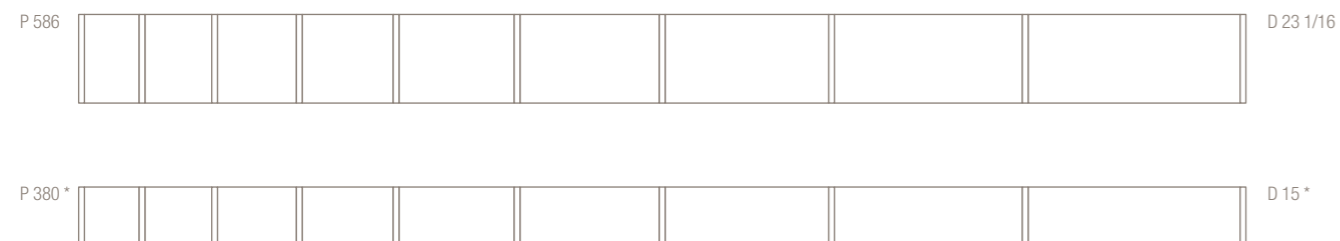
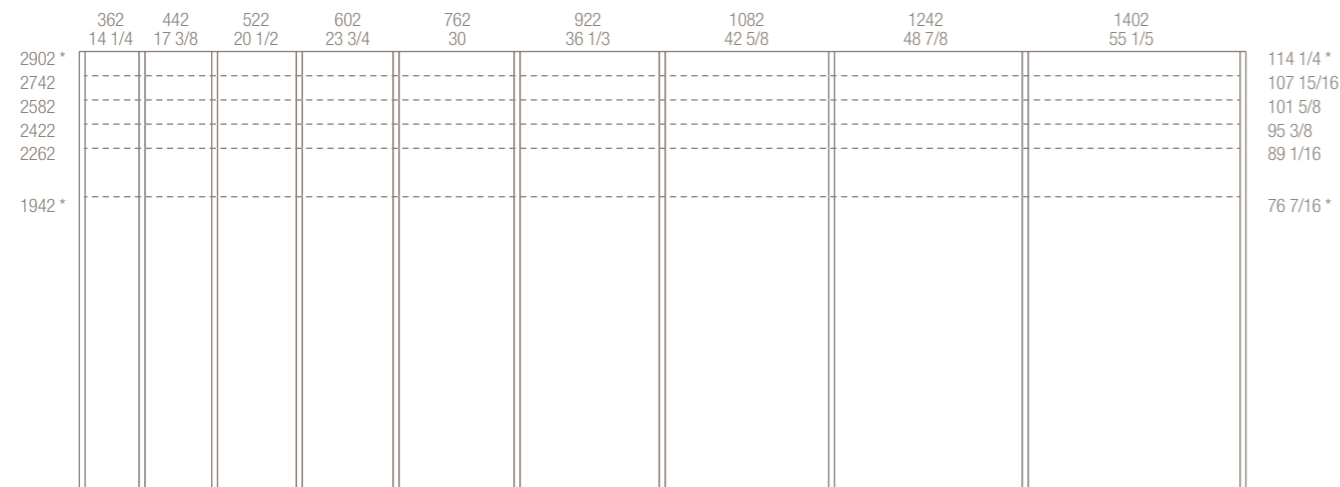

Misure espresse in **mm** e **pollici** _
Dimensions are shown in **mm** and **inches**

* Misure non disponibili per versioni scorrevoli e coplanari _
Measurements not available for sliding and coplanar doors.

MODULARITÀ _ MODULARITY

Il sistema prevede 2 spessori di spalle iniz./ term. Sp. 19 mm e Sp. 38 mm. Inoltre prevede la possibilità di avere una sovraspalla di Sp. 19 mm da utilizzare in finitura per la spalla iniz./term. di Sp. 19 mm (19+19 mm). Per ottenere la dimensione del **modulo iniz./term.** sommare alla dimensione del vano lo spessore della spalla terminale (19 mm o 38 mm o 19+19 mm). Per ottenere la dimensione del **modulo centrale** sommare alla dimensione del vano lo spessore della spalla centrale Sp. 38 mm. Per ottenere la lunghezza totale di una composizione sommare il **modulo iniziale + modulo centrale + spalla terminale** (19 mm o 38 mm o 19+19 mm).

*The system provides 2 init./term finishing side panels 19mm Th and 38mm Th. Furthermore, it provides the opportunity to have a 19mm Th. finishing side panels to use for the init/term 19mm Th. (19mm+19mm). in order to obtain the **init/term modular dimension**, pls. add the case dimension to the terminal side thickness (9mm or 38mm or 19+19mm). To obtain the **central dimension**, pls. add the case dimension to the central side thickness 38mm Th. To obtain the total length of a composition, pls. add the **initial module + the central module + the terminal side** (19mm or 38mm or 19+19mm).*

Senza ante _ Walk-in closet

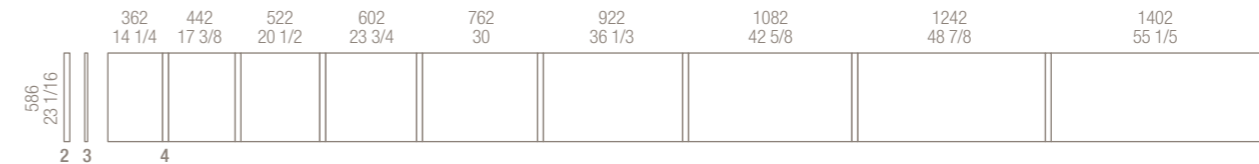

Battente _ Hinged door

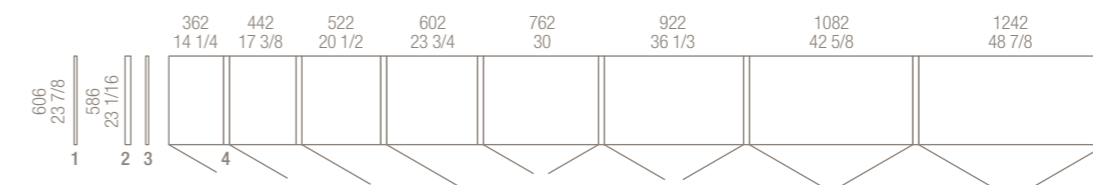

Scorrevole _ Sliding door

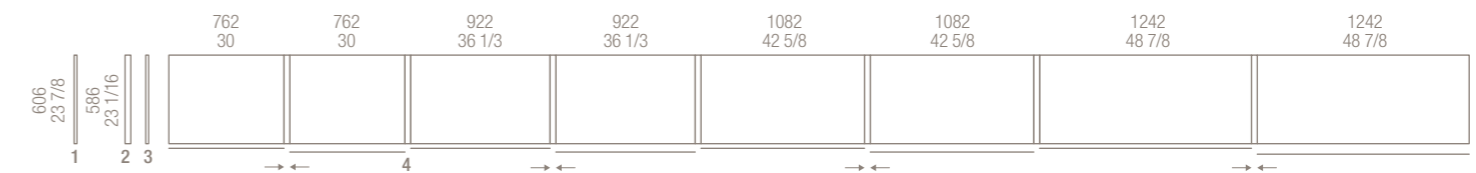

Coplanare _ Coplanar door

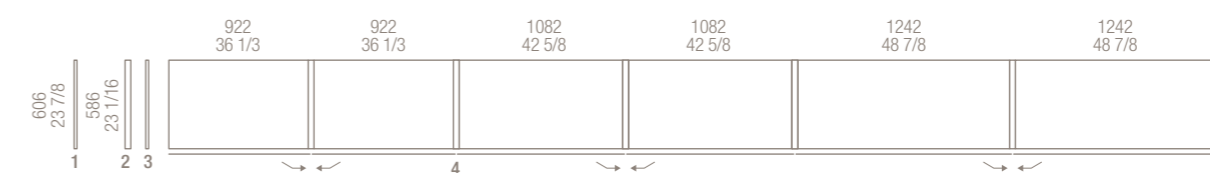

1. Sovraspalla (optional) Sp. 19 mm _ Finishing side panel (optional) Th. 6/8"
2. Spalla iniziale/terminale Sp. 38 mm _ Initial/terminal side panel Th. 1 1/2"

3. Spalla iniziale/terminale Sp. 19 mm _ Initial/terminal side panel Th. 6/8"
4. Spalla centrale Sp. 38 mm _ Central side panel Th. 1 1/2"

Dimensioni e componenti struttura _ Dimensions and structure components

COMPONENTI DELLA STRUTTURA PROFONDITÀ 586 MM _ STRUCTURE COMPONENTS DEPTH TH. 23 1/8

- 1 Spalla iniziale/terminale _ Initial/terminal side panel
- 2 Spalla centrale _ Central side panel
- 3 Coperchio _ Top
- 4 Schienale _ Back
- 5 Basamento _ Base
- 6 Sovraspalla _ Finishing side panel

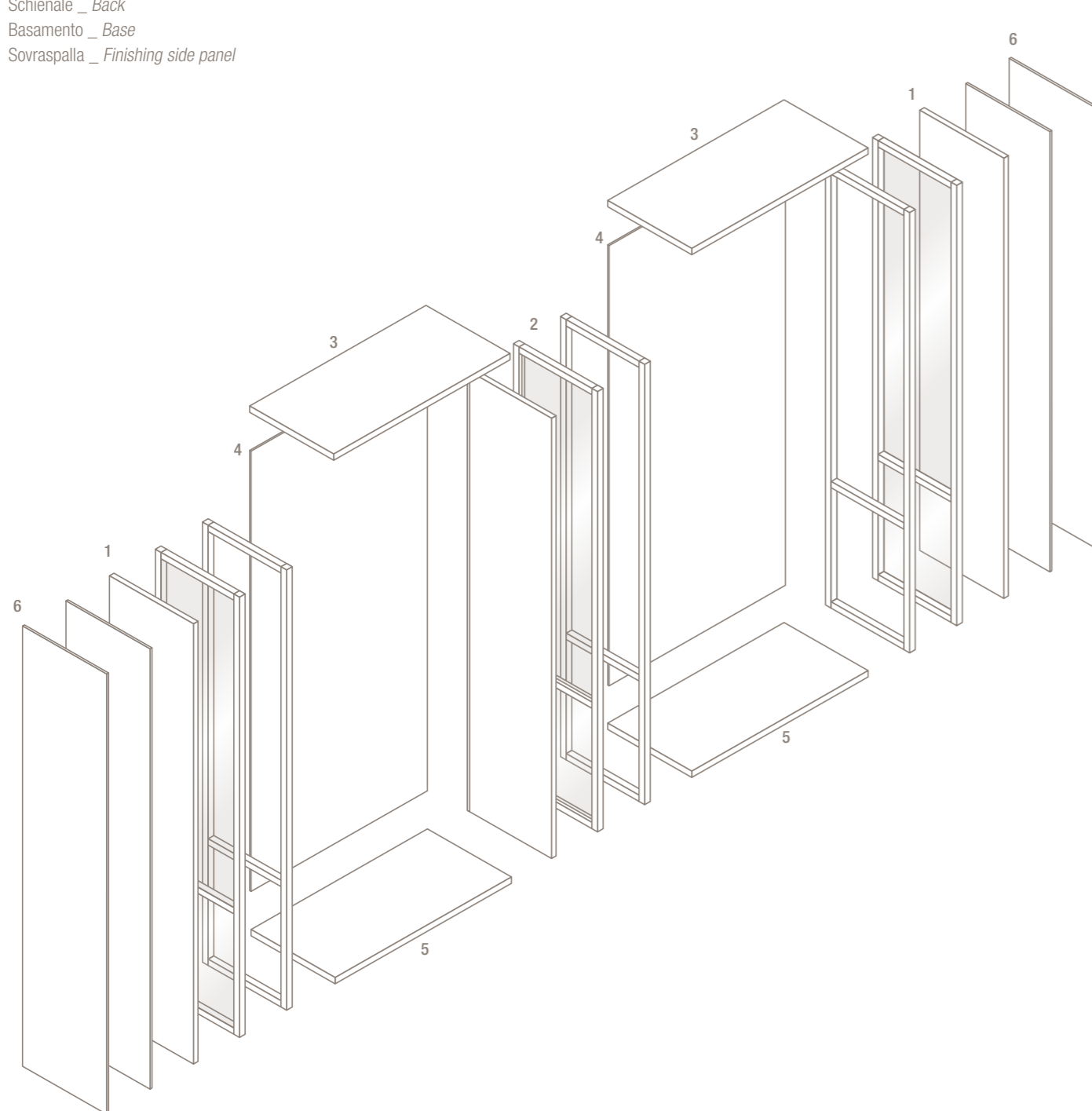

COMPONENTI DELLA STRUTTURA PROFONDITÀ 380 MM _ STRUCTURE COMPONENTS DEPTH TH. 15"

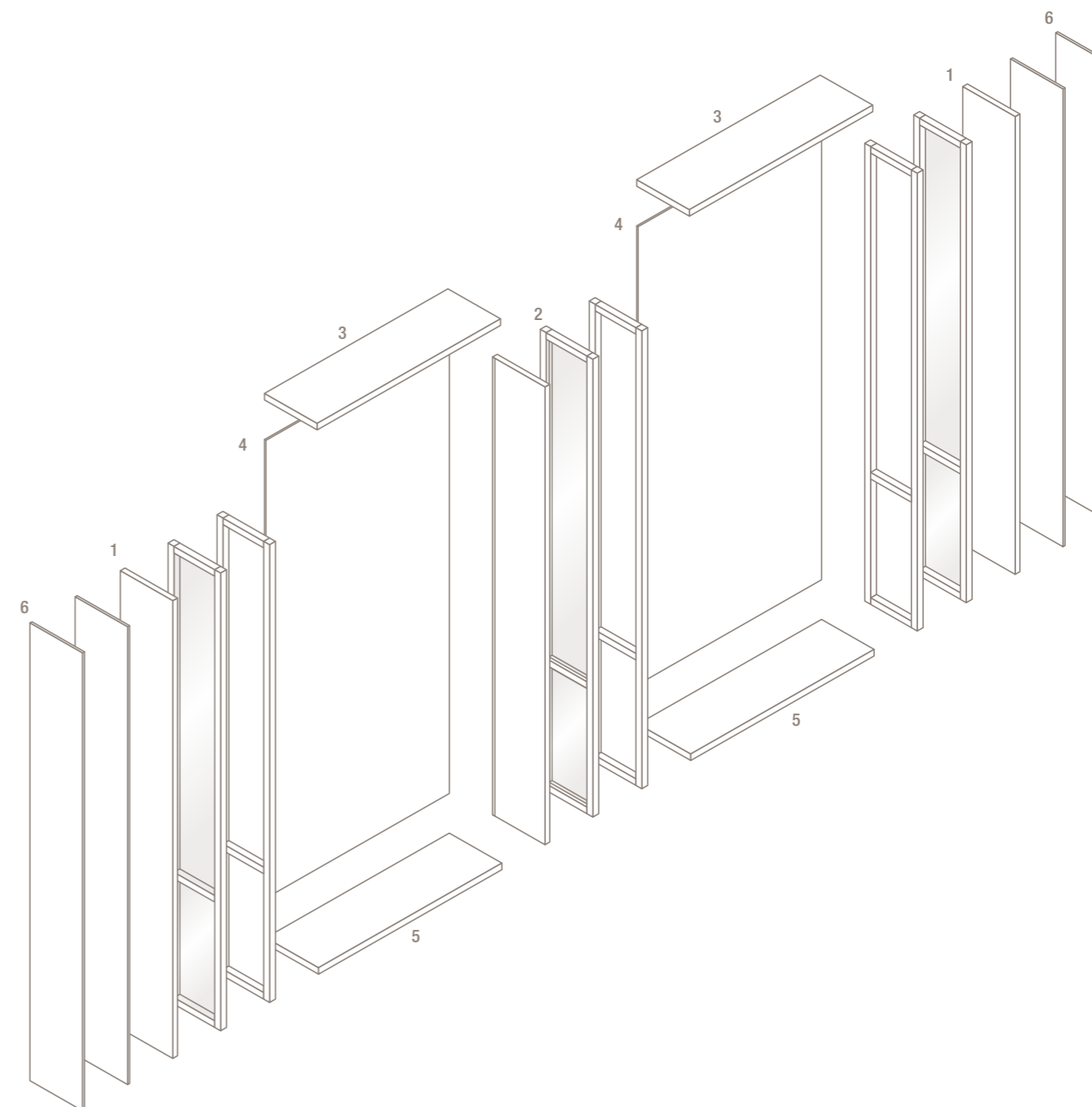

Dimensioni e componenti struttura _ Dimensions and structure components

TIPOLOGIE RIPIANI _ SHELVES TYPOLOGIES

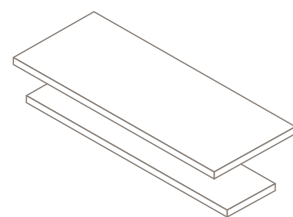

Ripiano Legno

Ripiano in particelle di legno nobilitato o laccato opaco Sp. 38 mm, P. 340 mm e 546 mm.

Wooden shelf

Chipboard shelf in melamine or matt lacquered Th. 1 1/2", D. 13 3/8" and 21 1/2".

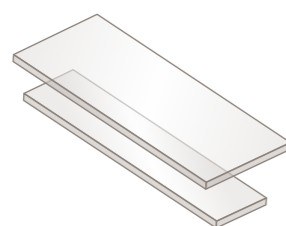

Ripiano Frame

Ripiano in vetro con telaio verniciato metallizzato Sp. 38 mm, P. 340 mm e 546 mm.

Frame shelf

Glass shelf with varnished metallised frame Th. 1 1/2", D. 13 3/8" and 21 1/2".

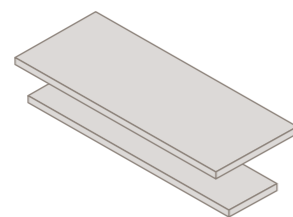

Ripiano Ecopelle

Ripiano in ecopelle con telaio verniciato metallizzato Sp. 38 mm, P. 340 mm e 546 mm.

Eco-leather Shelf

Eco-leather Shelf with varnished metallised frame Th. 1 1/2", D. 13 3/8" and 21 1/2".

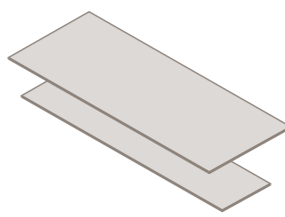

Ripiano Vetro

Ripiano in vetro Sp. 12 mm, P. 340 mm e 546 mm.

Glass shelf

Glass shelf Th. 1/2", D. 13 3/8" and 21 1/2".

TIPOLOGIE SCHIENALI _ BACK PANELS TYPOLOGIES



Schienale Legno

Schienale in particelle di legno nobilitato o laccato opaco Sp. 8 mm.

Wood back panel

Chipboard Back panel in melamine or matt lacquered Th. 3/8".



Schienale Vetro

Schienale in vetro Sp. 4 mm.

Glass back panel

Glass back panel Th. 1/8".



Schienale Tecno-marble

Schienale in tecno-marble Sp. 6 mm.

Tecno-marble back panel

Tecno-marble back panel Th. 2/8".

TIPOLOGIE SPALLE LEGNO _ WOOD SIDE PANEL TYPOLOGIES

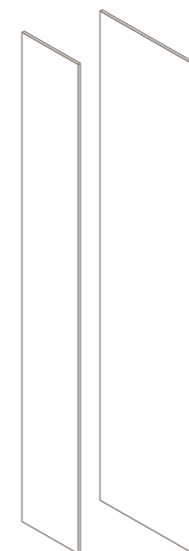

Spalla legno iniziale/terminale

Sp. 19 mm, P. 380 mm e 586 mm.

Init./term. wooden side panel

Th. 6/8", D. 15" and 23 1/8".

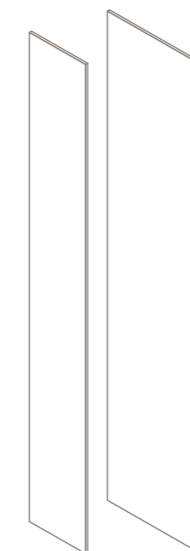

Sovrappalla legno

Sp. 19 mm, P. 400 mm e 606 mm.

Finishing wooden side panel

Th. 6/8", D. 15 6/8" and 23 7/8".

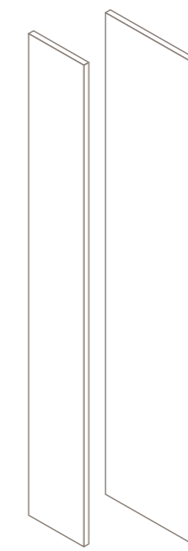

Spalla legno iniziale/terminale

Sp. 38 mm, P. 380 mm e 586 mm.

Init./term. wooden side panel

Th. 1 1/2", D. 15" and 23 1/8".

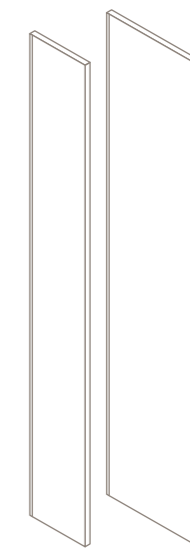

Spalla legno centrale

Sp. 38 mm, P. 380 mm e 586 mm.

Central wooden side panel

Th. 1 1/2", D. 15" and 23 1/8".

TIPOLOGIE SPALLE TELAIO _ FRAME SIDE TYPOLOGIES

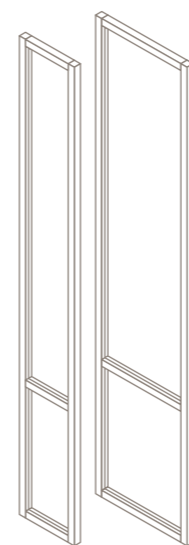

Spalla telaio iniz./term. senza vetro

Sp. 38 mm, P. 380 mm e 586 mm.

Init./term. side frame without glass

Th. 1 1/2", D. 15" and 23 1/8".

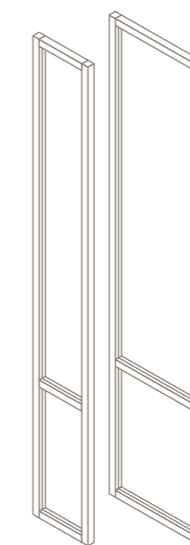

Spalla telaio centrale senza vetro

Sp. 38 mm, P. 380 mm e 586 mm.

Central side frame without glass

Th. 1 1/2", D. 15" and 23 1/8".

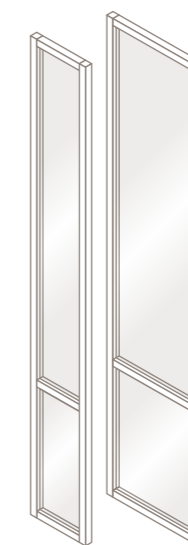

Spalla telaio iniz./term. con vetro

Sp. 38 mm, P. 380 mm e 586 mm.

Initial/term. side frame with glass

Th. 1 1/2", D. 15" and 23 1/8".

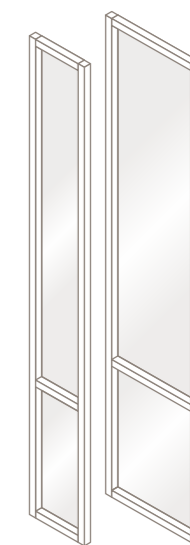

Spalla telaio centrale con vetro

Sp. 38 mm, P. 380 mm e 586 mm.

Central side frame with glass

Th. 1 1/2", D. 15" and 23 1/8".

Dimensioni e componenti struttura _ Dimensions and structure components

FOCUS ON SPALLE TELAIO _ FOCUS ON SIDE FRAME

L'innovativo profilo di Palo Alto I-Box può presentarsi in diverse configurazioni per accogliere le più svariate soluzioni compositive, grazie al suo design è possibile innestare vetri centrati o decentrati al profilo per comporre spalle iniziali, centrali o terminali; è studiato per permettere l'uso di schienali in diversi materiali come, legno, vetro o tecnomarble, permettendo il cambio di finitura tra un modulo e l'altro. I profili ospitano inoltre i canali led per l'illuminazione verticale.

The innovative Palo Alto I-Box upright can come in different configurations to accommodate a wide variety of compositional solutions, thanks to its design it is possible to insert glass panels centrally or offset to the profile to compose initial or terminal sides; it is designed to allow the use of backs in different materials such as, wood, glass or tecnomarble, also allowing for modular change of finish between modules. The profiles also house LED channels for vertical lighting.

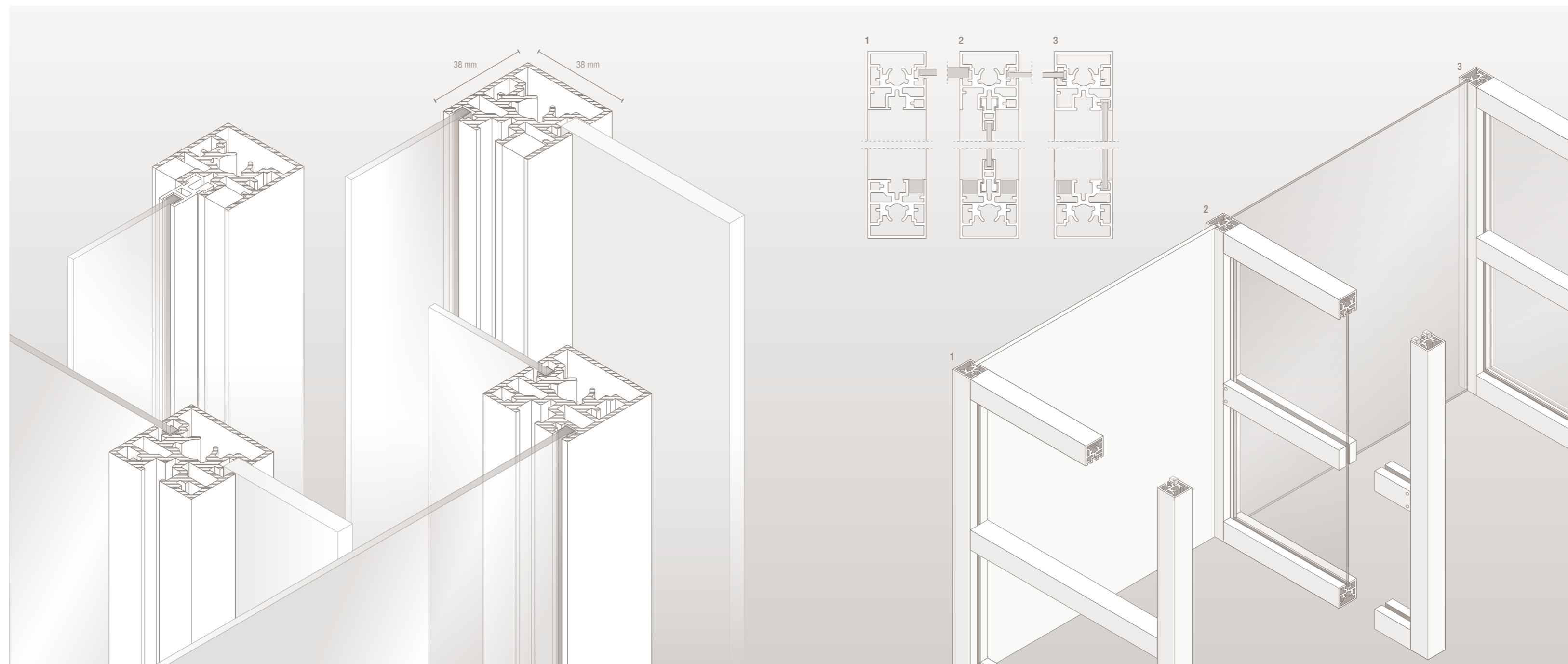

1.

Sezione orizzontale spalla telaio iniziale/terminale senza vetro (schienale vetro 4 mm)

Horizontal section of start/end frame side without glass (with glass back panel Th. 1/8")

2.

Sezione orizzontale spalla telaio centrale con vetro (schienale vetro 4 mm - legno 8 mm)

Central frame side with glass (glass back panel Th. 1/8" - wood back panel Th. 3/8")

3.

Sezione orizzontale spalla telaio iniziale/terminale con vetro (schienale vetro 4 mm)

Start/end frame side with glass (glass back panel Th. 1/8")

Dimensioni e componenti struttura _ Dimensions and structure components

TAMPONAMENTI _ FILLERS

01. FASCIA DI TAMPONAMENTO SUPERIORE _ TOP FILLER

Fascia di tamponamento superiore a filo anta. Attrezzabile con profilo compensatore di gomma per chiusura parete fuori squadra. Non è possibile utilizzare la fascia di tamponamento superiore con soluzioni a tipologia di apertura complanari. Dimensioni: H. da 60 mm a 320 mm. L. fino max. 3000 mm.

Door height top filler. Supplying with a rubber and a compensating profile to close up. It is not possible to use the top filler with coplanar opening solutions. Dimensions: from H. 2 3/8" to H. 12 5/8"; up to max L. 118 1/8".

02. FASCIA DI TAMPONAMENTO LATERALE _ SIDE FILLER

Fascia di tamponamento laterale utilizzabile a filo anta o lungo la struttura. Attrezzabile con profilo compensatore di gomma per chiusura parete fuori squadra. Il posizionamento della fascia di tamponamento laterale lungo la struttura, non è possibile in presenza di spalla telaio. Dimensioni: L. da 60 mm a 476 mm. H. fino max. 3000 mm.

Side filler which can be used along the door or the structure. Supplying with a rubber and a compensating profile to close up. The positioning of the side filler along the structure is not possible with a frame side. Dimensions: from W. 2 3/8" to W. 18 6/8"; up to max. H. 118 1/8".

03. TAMPONAMENTO AD ANTA APRIBILE _ OPENING DOOR FILLER

Possibilità di creare lateralmente un vano apribile con anta battente a misura. Cerniere dx o sx e pilastro di battuta a muro. Possibilità di attrezzare l'anta con un profilo compensatore di gomma per chiusura parete fuori squadra. Possibilità di chiusura push-pull.

It is possible to laterally provide an opening case with a tailored hinged door. Left or right zips and a wall pillar supplying with a rubber and a compensating profile to close up. Push-pull closure available.

04. ANTA SU MISURA PER TAMPONAMENTO _ TAILORED HINGE DOOR TO FILLER

Possibilità di avere ante più alte rispetto alla struttura. Questa soluzione non è realizzabile con tipologie di apertura scorrevoli e complanari. Nelle soluzioni con tipologie di aperture battenti non è possibile utilizzare le ante: Narcisse, Zeus, Rex.

It is possible to have doors taller than the structure. This solution is not possible with sliding and coplanar opening typologies. In the hinged door typologies, it is not possible to use the following doors: Narcisse, Zeus, Rex.

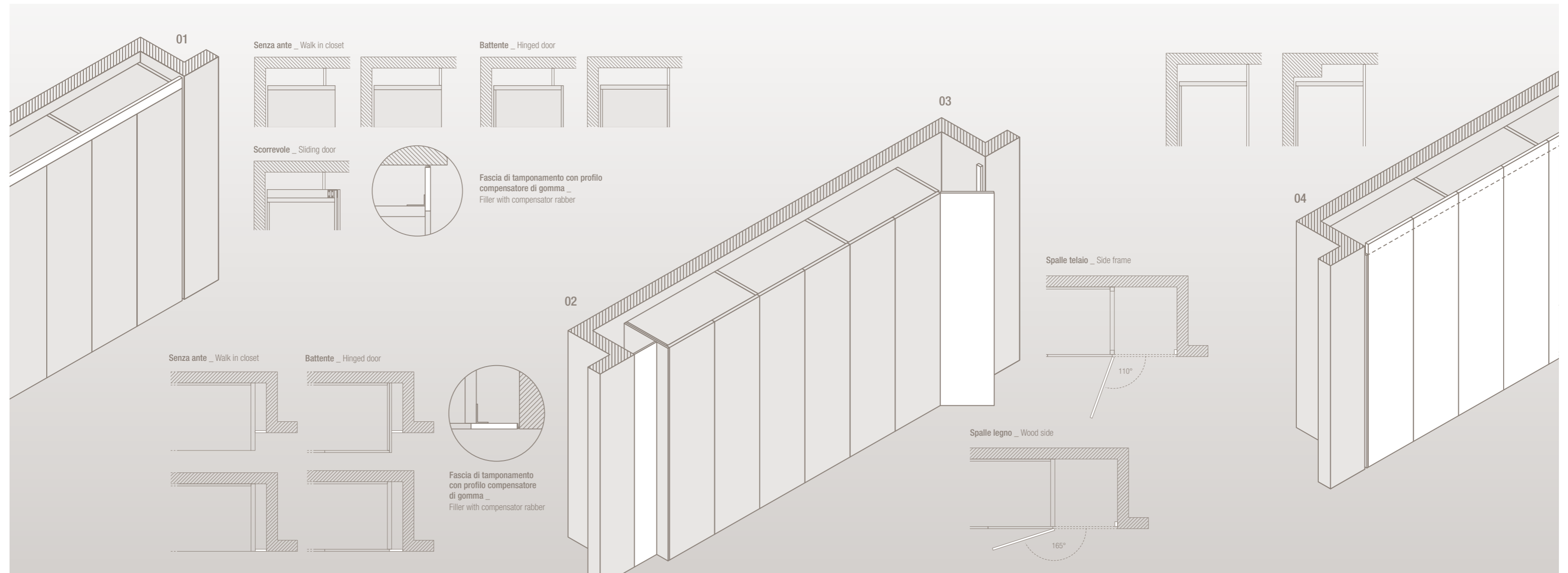

Dimensioni e componenti struttura _ Dimensions and structure components

RIDUZIONI _ REDUCTIONS

Sono possibili riduzioni in altezza, larghezza e profondità. Non è possibile la riduzione in altezza e in larghezza per le seguenti ante: Narcisse, Zeus, Rex, London. Non sono ammesse riduzioni in profondità per strutture con spalle telaio.

Possible reductions in height, width and depth. As for Narcisse, Zeus, Rex and London doors a decrease in height and width is not possible. Reductions in depth for frame side structures not allowed.

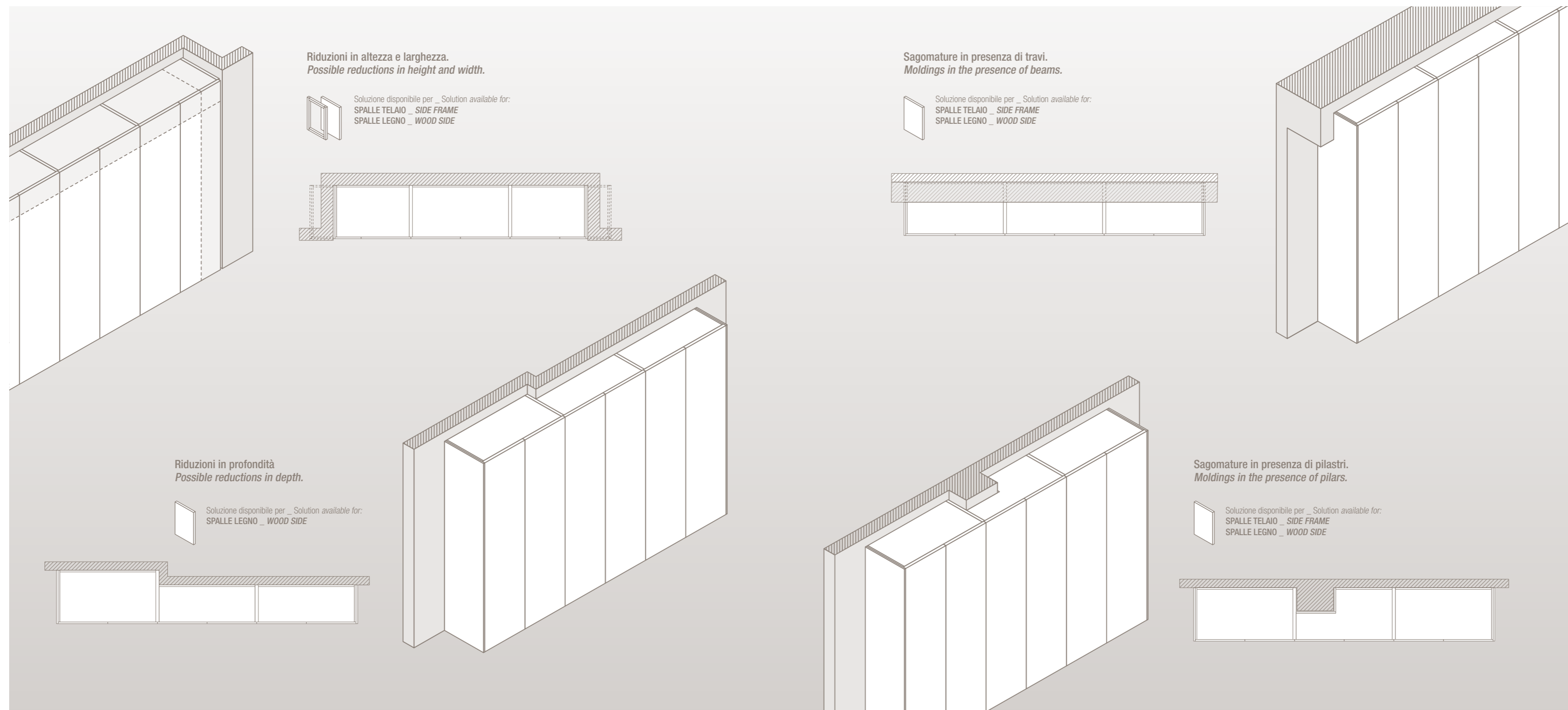

SAGOMATURE _ MOULDINGS

Sono possibili sagomature particolari in presenza di pilastri. Questa soluzione non è realizzabile per strutture con spalle telaio, tipologie di aperture scorrevoli e coplanari.

Possible particular mouldings with pilars. Impossible for frame side structures, sliding and coplanar opening typologies.

Finiture struttura _ *Structure finishings*



Finiture struttura _ Structure finishings

SPALLA LEGNO / BASAMENTO / COPERCHIO _ SIDE PANEL / BASE SHELF / TOP SHELF

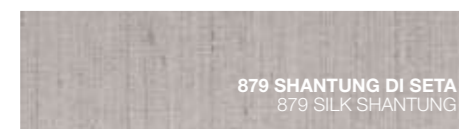
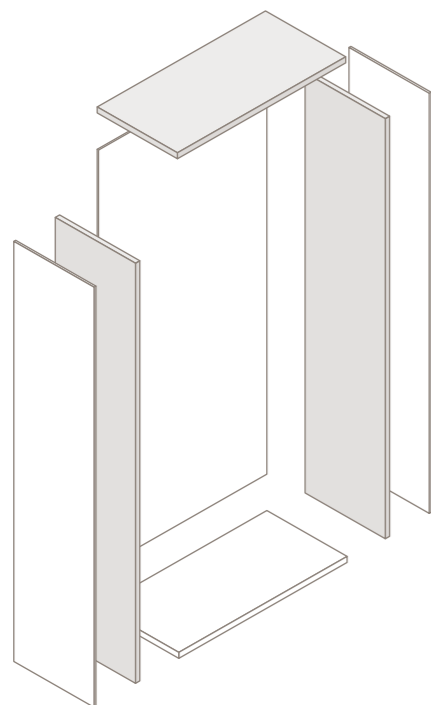

NOBITATI TESSUTO _ FABRIC MELAMINES

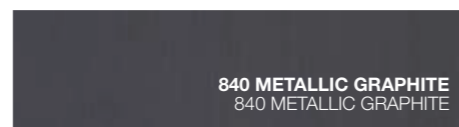
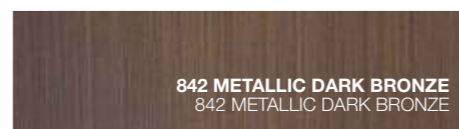
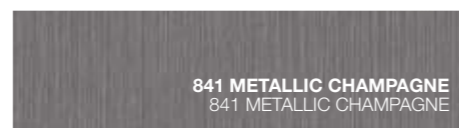

NOBITATI METALLIZZATI _ METALLIC MELAMINES



COLORI LACCATI _ LACQUERED COLOURS



NOBITATI LISCIO _ SMOOTH MELAMINE

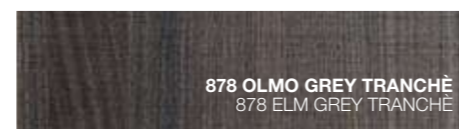

NOBITATI LEGNO _ WOODEN MELAMINES

SOVRASPALLA _ FINISHINGS SIDE PANEL

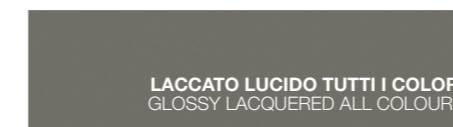
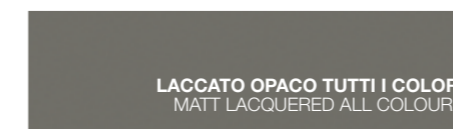
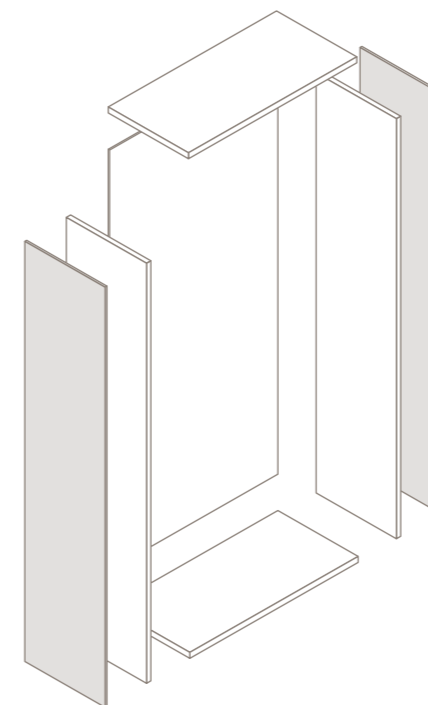

COLORI LACCATI _ LACQUERED COLOURS



NOBITATI LEGNO _ WOOD MELAMINE

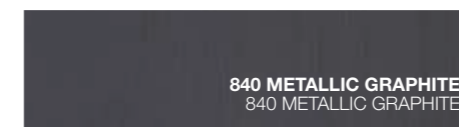
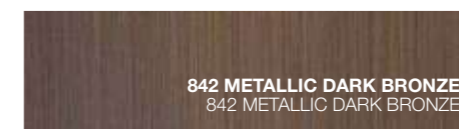

NOBITATI METALLIZZATI _ METALLIC MELAMINES

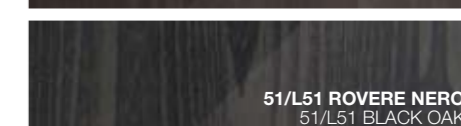

ESSENZE OPACHE/LUCIDE _ MATT/GLOSSY WOOD

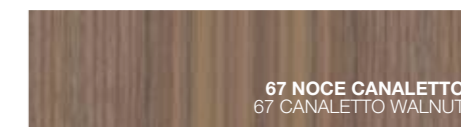

ESSENZE OPACHE _ MATT WOOD

Finiture struttura _ Structure finishings

SPALLA TELAIO SENZA VETRO / SPALLA TELAIO CON VETRO _ FRAME SIDE WITHOUT GLASS / FRAME SIDE WITH GLASS

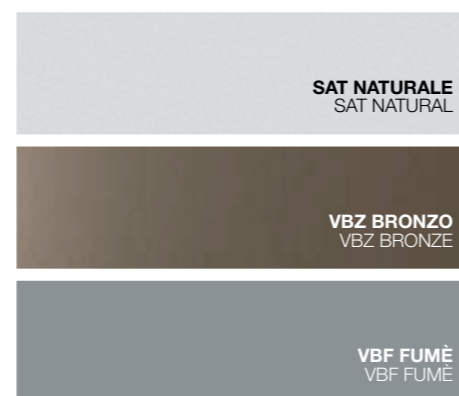
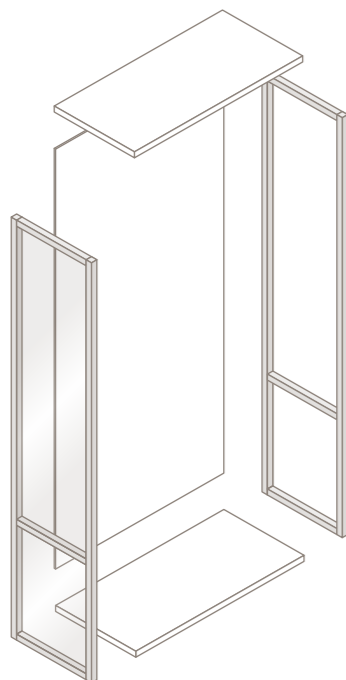

VETRI BICIDATI _ FROSTED GLASSES



VETRI TRASPARENTI _ TRANSPARENT GLASSES



VETRI RIFLETTENTI _ REFLECTING GLASSES

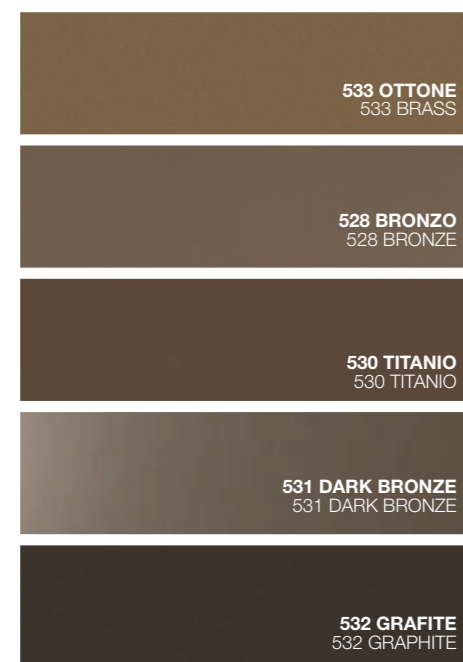

METALLI _ METALS

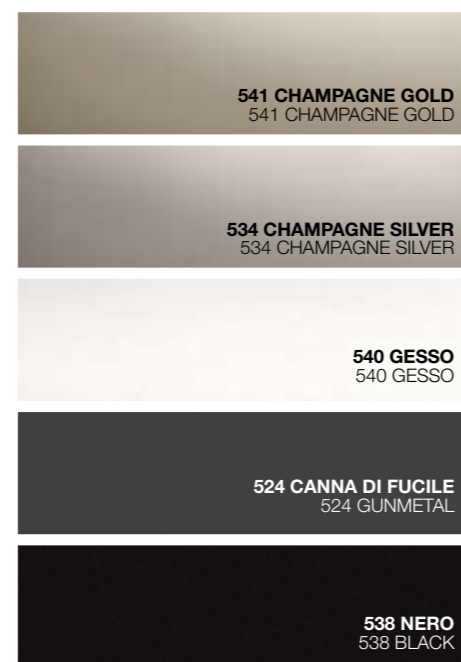

METALLI _ METALS

SCHIENALE _ BACK PANEL

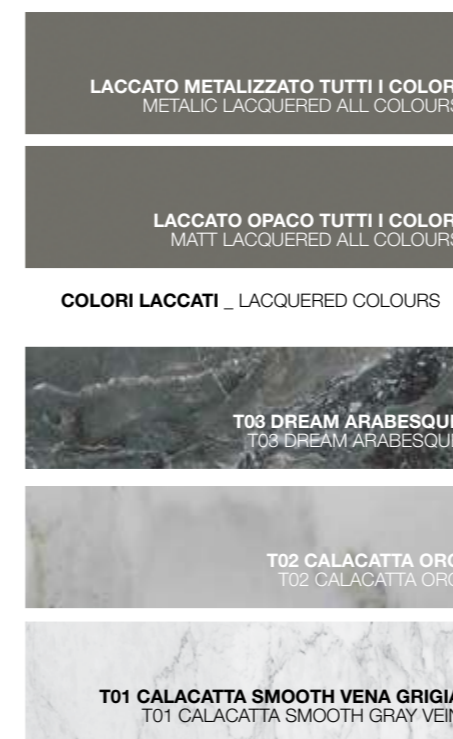
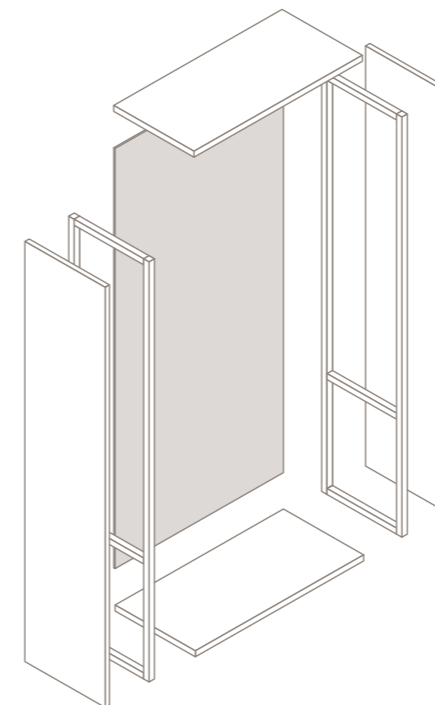

TECNOMARMO _ TECNOMARBLE



VETRI BICIDATI _ FROSTED GLASSES



SPECCHI TEMPERATI _ TEMPERED MIRRORS

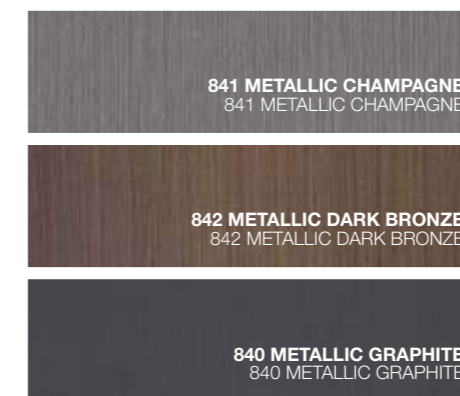

NOBILITATI METALLIZZATI _ METALLIC MELAMINE



NOBILITATI TESSUTO _ FABRIC MELAMINES



VETRI TRASPARENTI _ TRANSPARENT GLASSES

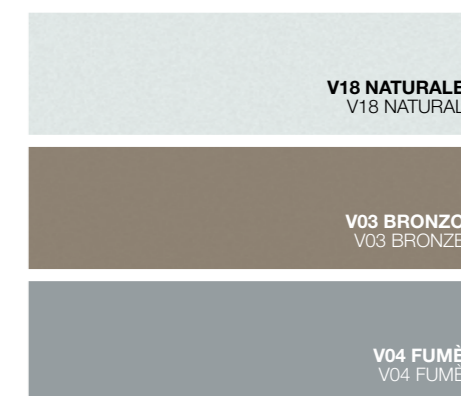

VETRI RIFLETTENTI _ REFLECTING GLASSES

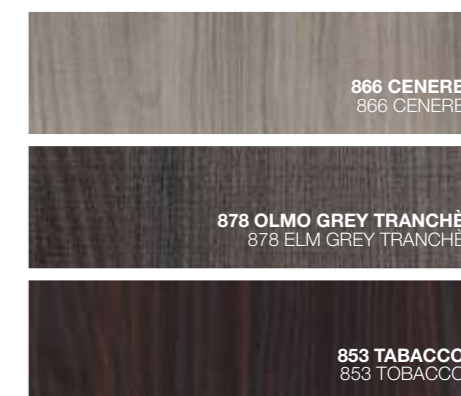

NOBILITATI LEGNO _ WOOD MELAMINE



NOBILITATO LISCIO _ SMOOTH MELAMINE

Tipologia aperture _ *Opening typologies*





Tipologia aperture _ Opening typologies

SENZA ANTE _ WALK-IN CLOSET

La tipologia SENZA ANTE è un particolare sottoinsieme di soluzioni del sistema Palo Alto I-Box nel quale non vi è presenza di alcuna anta. Sono possibili integrazioni fra queste soluzioni e le altre soluzioni del sistema. Per maggiori dettagli vedi capitolo INTEGRAZIONI pag. 105. Queste soluzioni prevedono 6 dimensioni in altezza, 2 in profondità, 9 in larghezza e sono realizzabili sia con le spalle legno, sia con spalle telaio.

- 1 Hi-tech
- 2 Basic

WALK-IN CLOSET typology is a particular subset of Palo Alto I-Box system solutions, in which there are no doors. Some integrations among these solutions and others of the system are possible. For further information, pls see chapter INTEGRATIONS on page 105. These solutions provide 6 dimensions (height), 2 (depth) and 9 (width). Their manufacture is possible both with wooden sides and frame ones.

- 1 Hi-tech
- 2 Basic



1



2

Tipologia aperture _ Opening typologies

SENZA ANTE _ WALK-IN CLOSET

Struttura spalla legno _ Structure with wooden side panel

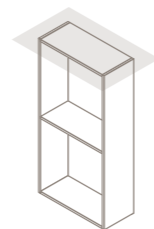

Sezioni laterali _ Side sections

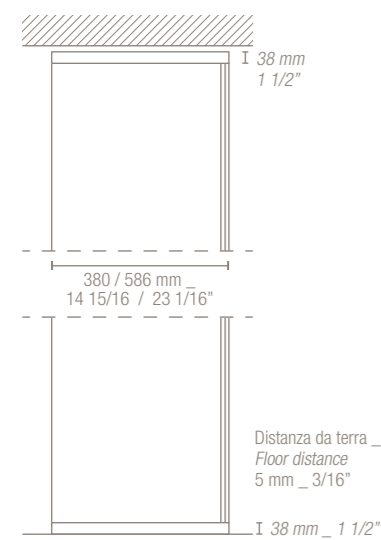

Distanza minima da soffitto _ Minimum distance from ceiling

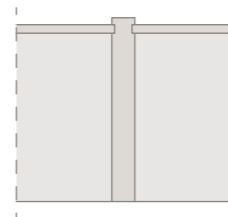
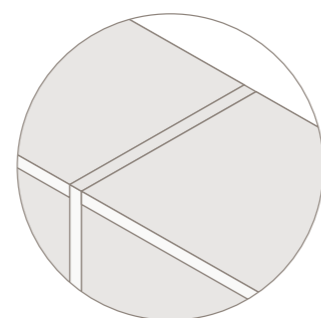
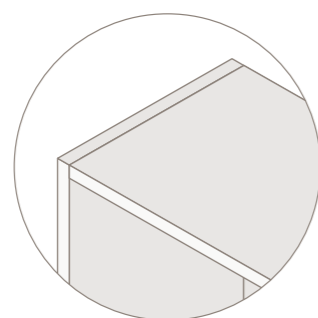
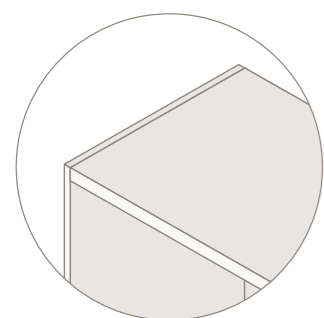
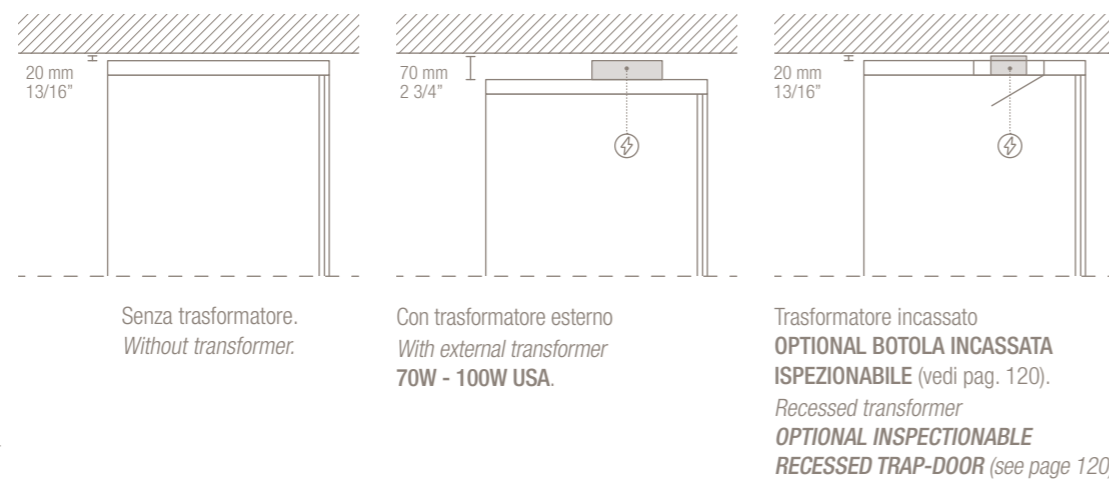

Spalla legno iniz./term.

Finiture: Nobilitato o laccato opaco.
Sp.19 mm. P. 380 mm e 586 mm.

Init./term. wooden side panel

Finishings: Melamine or matt lacquered.
Th. 6/8". D. 15" and 23 1/8".

Spalla legno iniz./term.

Finiture: Nobilitato o laccato opaco.
Sp.38 mm. P. 380 mm e 586 mm.

Init./term. wooden side panel

Finishings: Melamine or matt lacquered.
Th. 1 1/2". D. 15" and 23 1/8".

Spalla legno centrale

Finiture: Nobilitato o laccato opaco.
Sp.38 mm. P. 380 mm e 586 mm.

Central wooden side panel

Finishings: Melamine or matt lacquered.
Th. 1 1/2". D. 15" and 23 1/8".

Struttura spalla telaio _ Structure with frame side

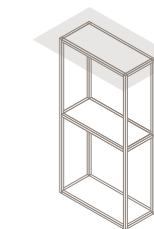

Sezioni laterali _ Side sections

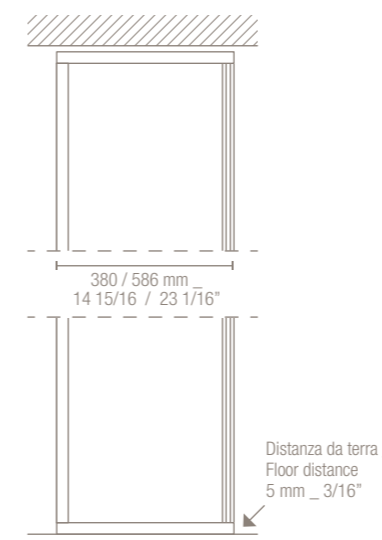

Distanza minima da soffitto _ Minimum distance from ceiling

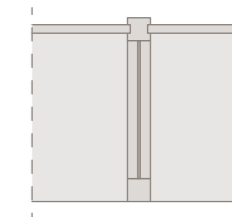
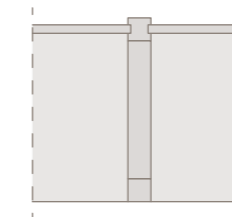
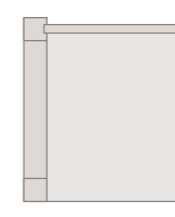
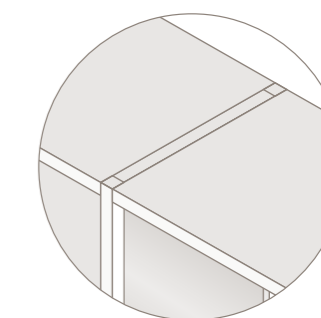
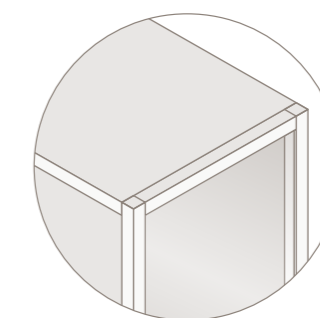
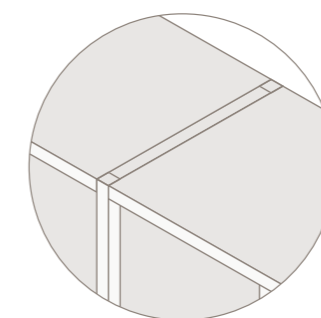
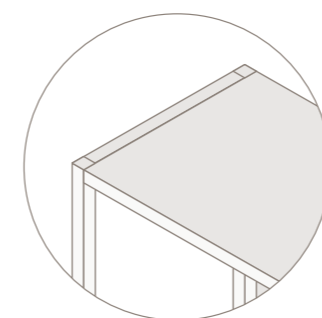
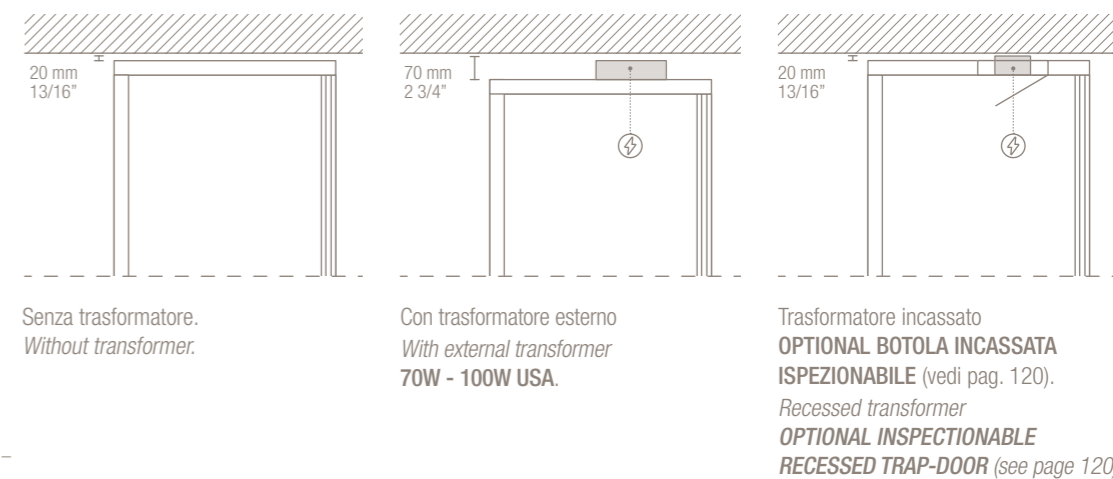

Spalla telaio iniz./term. senza vetro

Finiture: Alluminio verniciato metallizzato. Sp.38 mm. P. 380 mm e 586 mm.

Init./term. side frame without glass

Finishings: Metallic varnished aluminum. Th. 1 1/2". D. 15" and 23 1/8".

Spalla telaio centrale senza vetro

Finiture: Alluminio verniciato metallizzato. Sp.38 mm. P. 380 mm e 586 mm.

Central side frame without glass

Finishings: Metallic varnished aluminum. Th. 1 1/2". D. 15" and 23 1/8".

Spalla telaio iniz./term. con vetro

Finiture: Alluminio verniciato metallizzato e vetro Sp. 4mm in 12 varianti. Sp.38 mm. P. 380 mm e 586 mm.

Init./term. side frame with glass

Finishings: Metallic varnished aluminum and Th. 1/8" glass in 12 variants. Th. 1 1/2". D. 15" and 23 1/8".

Spalla telaio centrale con vetro

Finiture: Alluminio verniciato metallizzato e vetro Sp. 4mm in 12 varianti. Sp.38 mm. P. 380 mm e 586 mm.

Central side frame with glass

Finishings: Metallic varnished aluminum and Th. 1/8" glass in 12 variants. Th. 1 1/2". D. 15" and 23 1/8".



Tipologia aperture _ Opening typologies

BATTENTE / CASSETTI ESTERNI _ HINGED DOOR EXTERNAL DRAWERS

La tipologia BATTENTE/CASSETTI ESTERNI è un particolare sottoinsieme di soluzioni del sistema Palo Alto I-Box nel quale vi è solo presenza di ante battenti. Sono possibili integrazioni fra queste soluzioni e le altre soluzioni del sistema. Queste soluzioni prevedono 6 dimensioni in altezza, 2 in profondità, 8 in larghezza e sono realizzabili sia con le spalle legno, sia con spalle telaio. Tutte le ante battenti sono fornite con cerniere chiusura SOFT-CLOSING. La maniglia è montata sull'anta destra. È possibile avere come optional la maniglia sull'anta sinistra.

Ante
 Tecno, Milano, First, Brillanta, London, Zeus, Narcisse, Rex.

- 1 Hi-tech
- 2 Basic

The HINGED DOOR EXTERNAL DRAWER typology is a particular subset of Palo Alto I-Box system solutions, in which there are only hinged doors. Some integrations among these solutions and others of the system are possible. These solutions provide 6 dimensions (height), 2 (depth) and 8 (width). Their manufacture is possible both with wooden sides and frame ones. All hinged doors are supplied with "SOFT-CLOSING" closing hinges. The handle is mounted on the right door. It is possible to optionally have the handle on the left door.

Doors
 Tecno, Milano, First, Brillanta, London, Zeus, Narcisse, Rex.

- 1 Hi-tech
- 2 Basic



1



2

Tipologia aperture _ Opening typologies

BATTENTE / CASSETTI ESTERNI _ HINGED DOOR EXTERNAL DRAWERS

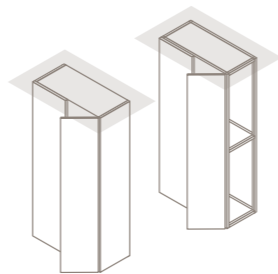

Sezioni laterali _ Side sections

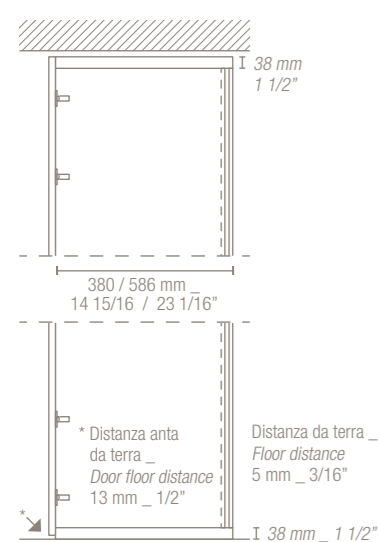

Distanza minima da soffitto _ Minimum distance from ceiling

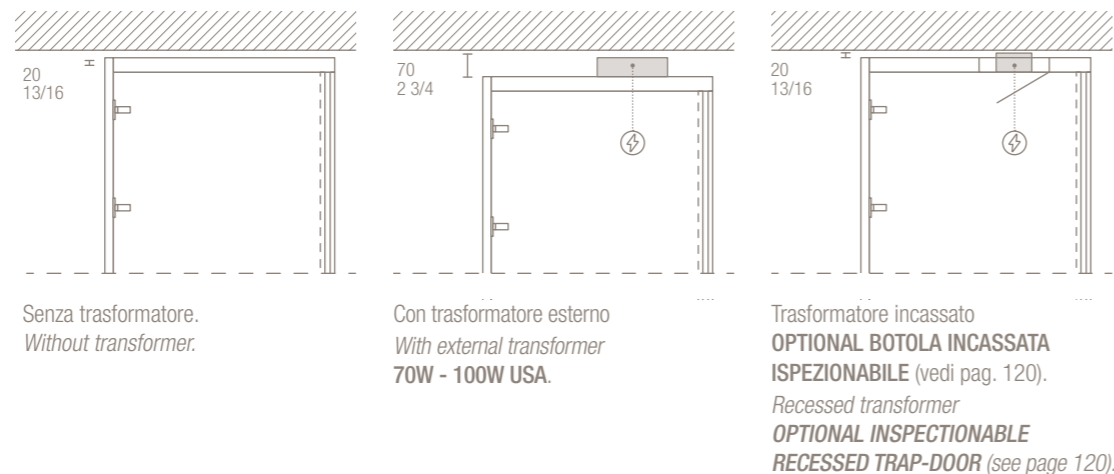

Struttura spalla legno _ Structure with wooden side panel

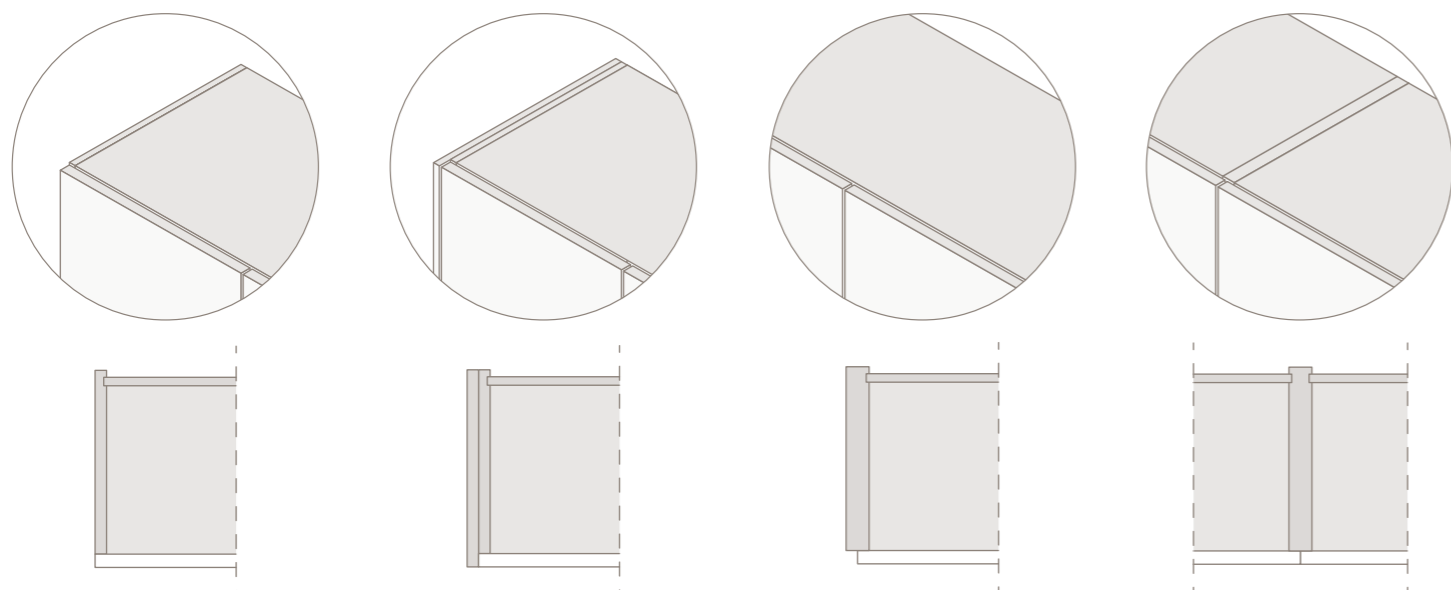

Spalla legno iniz./term.

Finiture: Interno nobilitato o laccato opaco.
Esterno nobilitato, lacc. opaco, lacc. lucido o
essenza. Sp.19 mm, P. 380 mm e 586 mm.

Init./term. wooden side panel

Finishings: Melamine or matt lacquered
inside. Melamine, matt lacquered, glossy
lacquered or wood outside. Th. 6/8", D. 15"
and 23 1/8".

Sovrappalla legno (optional)

Finiture: essenza, nobilitato, laccato
opaco e laccato lucido.
Sp.19 mm, P. 400 mm e 606 mm.

Finishing wooden side panel (optional)

Finishings: Wood, melamine, matt
lacquered and glossy lacquered.
Th. 6/8", D. 15 6/8" and 23 7/8".

Spalla legno iniz./term.

Finiture: Interno nobilitato o lacc. opaco.
Esterno nobilitato, lacc. opaco, lacc. lucido o
essenza. Sp.38 mm, P. 380 mm e 586 mm.

Init./term. wooden side panel

Finishings: Melamine or matt lacquered
inside. Melamine, matt lacquered, glossy
lacquered or wood outside. Th. 1 1/2", D.
15" and 23 1/8".

Spalla legno centrale

Finiture: Nobilitato o laccato opaco.
Sp.38 mm, P. 380 mm e 586 mm.

Central wooden side panel

Finishings: Melamine or matt lacquered.
Th. 1 1/2", D. 15" and 23 1/8".

Modularità altezza cassetti esterni _ External drawers height modularity

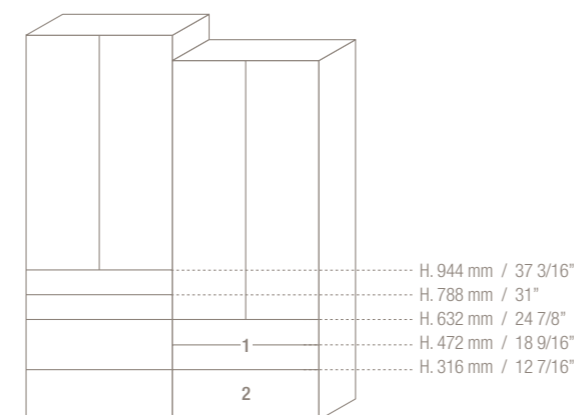

N.B.

I cassetti esterni non possono essere utilizzati in presenza di spalle telaio.
Il primo cassetto inferiore deve essere obbligatoriamente H. 316 mm.
Possono essere realizzabili solo con le ante: Tecno, Milano, First,
Brillante, London.

N.B.

The external drawers can be used with frame sides. The first lower
drawer must amount to 316mm H. These drawers can only be provided
with the following doors: Tecno, Milano, First, Brillanta and London.

1. Cassetti H. 156 mm _ Drawers H. 6 1/8"
2. Cassetti H. 316 mm _ Drawers H. 12 1/2"

Struttura spalla telaio _ Structure with frame side

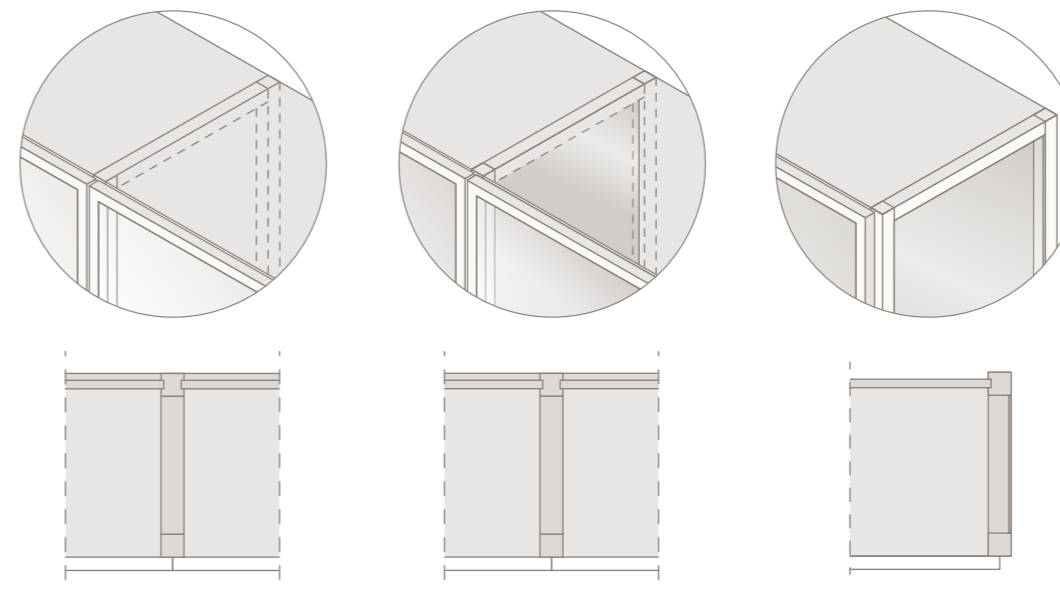

Spalla telaio centrale senza vetro

Finiture: Alluminio verniciato metallizzato.
Sp.38 mm, P. 380 mm e 586 mm.

Central side frame without glass

Finishings: Metallic varnished aluminum.
Th. 1 1/2", D. 15" and 23 1/8".

Spalla telaio iniz./term. con vetro

Finiture: Alluminio verniciato metallizzato
e vetro Sp. 4mm in 12 varianti.
Sp.38 mm, P. 380 mm e 586 mm.

Init./term. side frame with glass

Finishings: Metallic varnished aluminum
and Th. 1/8" glass in 12 variants. Th. 1
1/2", D. 15" and 23 1/8".

Spalla telaio centrale con vetro

Finiture: Alluminio verniciato metallizzato
e vetro Sp. 4mm in 12 varianti.
Sp.38 mm, P. 380 mm e 586 mm.

Central side frame with glass

Finishings: Metallic varnished aluminum
and Th. 1/8" glass in 12 variants. Th. 1
1/2", D. 15" and 23 1/8".



Tipologia aperture _ Opening typologies

BATTENTE/RX6 _ HINGED/RX6

La tipologia RX6 è un particolare sottoinsieme dell'anta Rex. Contraddistinta da un'apertura innovativa con meccanismo, tipo pantografo, che permette di traslare una o più coppie di ante dalla loro posizione di chiusura a quella di totale apertura a 180°, sovrapponendole alle ante del vano adiacente. Si ottengono così aperture totali di vani di due metri circa. Sono possibili INTEGRAZIONI con altre tipologie di ante battenti. Queste soluzioni prevedono 3 dimensioni in altezza, 2 in larghezza e sono realizzabili sia con le spalle legno, sia con spalle telaio. La maniglia Rex è standard per questa tipologia.

The RX6 typology is a particular subset of the hinged Rex door. Featuring an innovative opening mechanism, similar to a pantograph, that permits the movement of one or more pairs of doors from their closed position to total 180° opening, placed over the doors of the adjacent compartment. The result is the total opening of spaces of about two meters. INTEGRATIONS with other hinged doors are possible. These solutions provide 3 dimensions (height), and 2 (width). Their manufacture is possible both with wooden sides and frame ones. Rex handle is standard for this type.

Ante

Rex

- 1 Hi-tech
- 2 Basic

Doors

Rex

- 1 Hi-tech
- 2 Basic



1



2

Tipologia aperture _ *Opening typologies*

BATTENTE/RX6 _ *HINGED/RX6*

Struttura spalla legno _ *Structure with wooden side panel*

Sezioni laterali _ *Side sections*

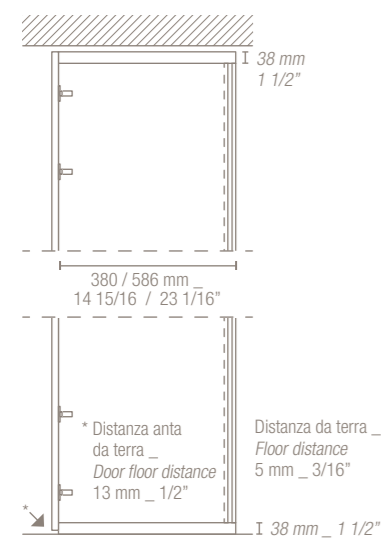

Distanza minima da soffitto _ *Minimum distance from ceiling*

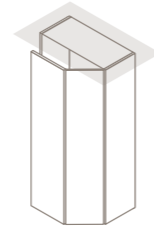
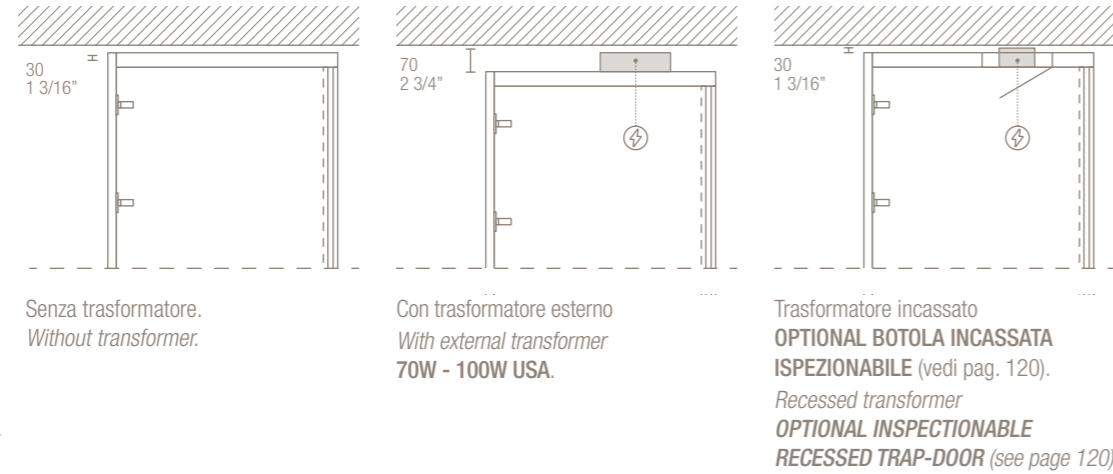

Struttura spalla legno _ *Structure with wooden side panel*

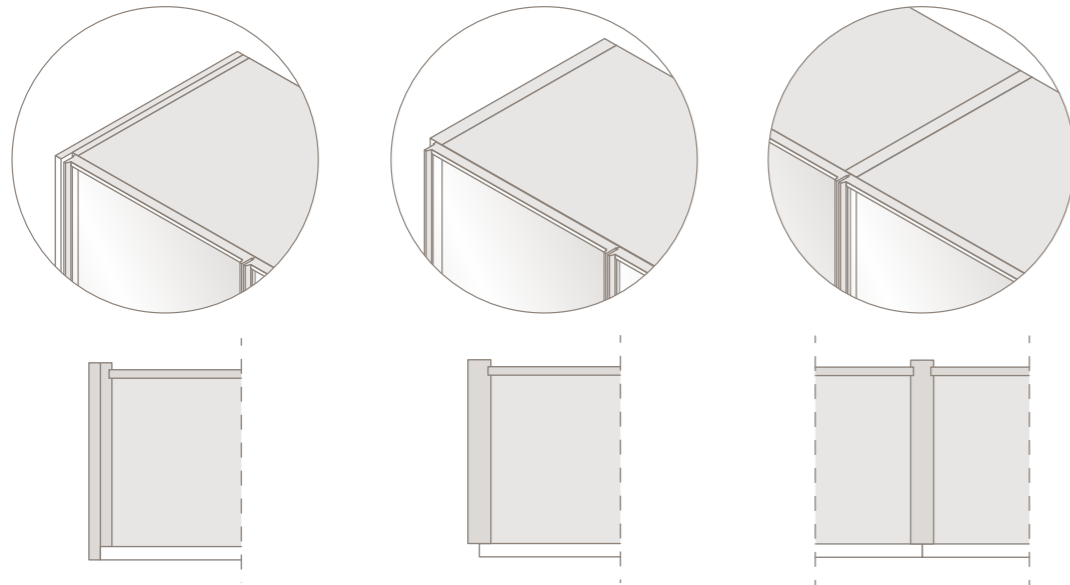

Sovraspalla legno (optional)

Finiture: essenza, nobilitato, laccato opaco e laccato lucido.
Sp. 19 mm, P. 400 mm e 606 mm.

Finishing wooden side panel (optional)

Finishings: Wood, melamine, matt lacquered and glossy lacquered.
Th. 6/8", D. 15 6/8" and 23 7/8".

Spalla legno iniz./term.

Finiture: Interno nobilitato o lacc. opaco. Esterno nobilitato, lacc. opaco, lacc. lucido o essenza. Sp. 38 mm, P. 380 mm e 586 mm.

Init./term. wooden side panel

Finishings: Melamine or matt lacquered inside. Melamine, matt lacquered, glossy lacquered or wood outside. Th. 1 1/2", D. 15" and 23 1/8".

Spalla legno centrale

Finiture: Nobilitato o laccato opaco.
Sp. 38 mm, P. 380 mm e 586 mm.

Central wooden side panel

Finishings: Melamine or matt lacquered.
Th. 1 1/2", D. 15" and 23 1/8".

Struttura spalla telaio _ *Structure with frame side*

Sezioni laterali _ *Side sections*



Distanza minima da soffitto _ *Minimum distance from ceiling*

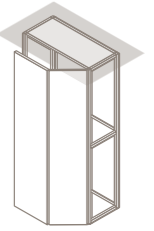
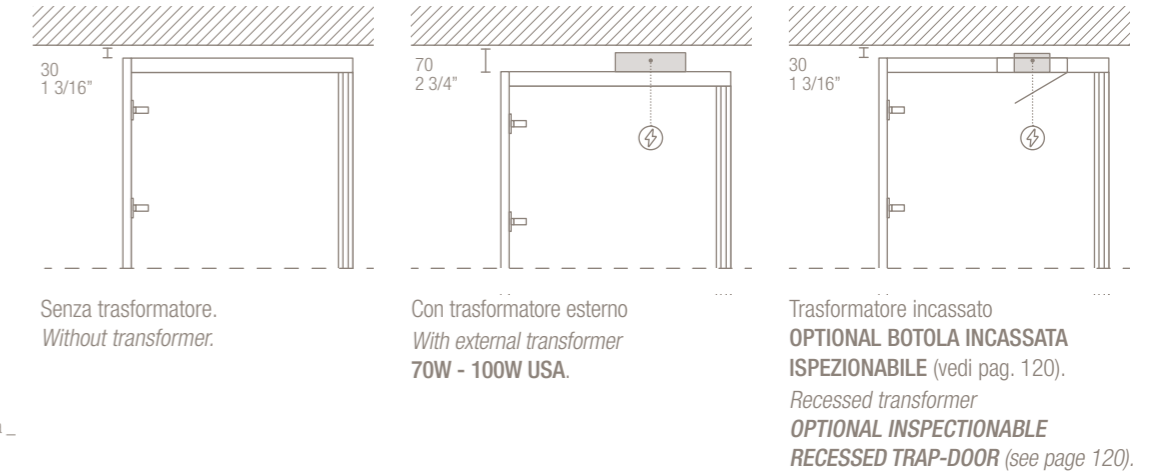

Struttura spalla telaio _ *Structure with frame side*

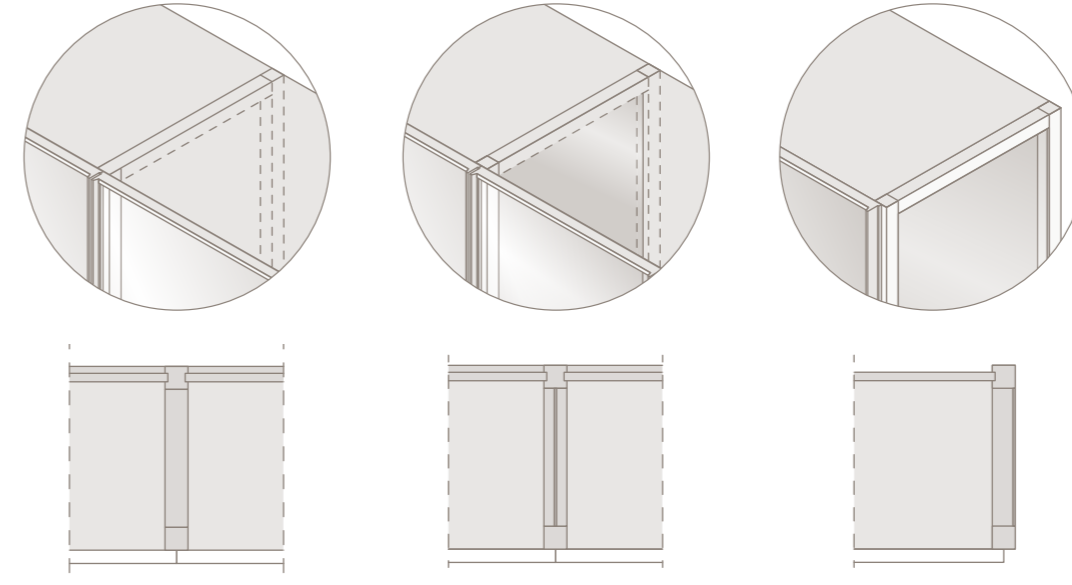

Spalla telaio centrale senza vetro

Finiture: Alluminio verniciato metallizzato.
Sp. 38 mm, P. 380 mm e 586 mm.

Central side frame without glass

Finishings: Metallic varnished aluminum.
Th. 1 1/2", D. 15" and 23 1/8".

Spalla telaio iniz./term. con vetro

Finiture: Alluminio verniciato metallizzato e vetro Sp. 4mm in 12 varianti.
Sp. 38 mm, P. 380 mm e 586 mm.

Init./term. side frame with glass

Finishings: Metallic varnished aluminum and Th. 1/8" glass in 12 variants. Th. 1 1/2", D. 15" and 23 1/8".

Spalla telaio centrale con vetro

Finiture: Alluminio verniciato metallizzato e vetro Sp. 4mm in 12 varianti.
Sp. 38 mm, P. 380 mm e 586 mm.

Central side frame with glass

Finishings: Metallic varnished aluminum and Th. 1/8" glass in 12 variants. Th. 1 1/2", D. 15" and 23 1/8".



Tipologia aperture _ Opening typologies

SCORREVOLE _ SLIDING DOOR

La tipologia SCORREVOLE è un particolare sottoinsieme di soluzioni del sistema Palo Alto I-Box nel quale vi è solo presenza di ante scorrevoli. Sono possibili integrazioni fra queste soluzioni e le altre soluzioni del sistema. Per maggiori dettagli vedi capitolo INTEGRAZIONI pag. 105. Queste soluzioni prevedono 4 dimensioni in altezza, 1 in profondità, 4 in larghezza e sono realizzabili sia con le spalle legno, sia con spalle telaio. Tutte le ante scorrevoli sono fornite con carrelli di scorrimento/raddrizzante/perno anti-collisione di serie. L'anta scorrevole esterna è fornita con una maniglia applicata al lato opposto al senso di apertura. Su richiesta è possibile avere coppia maniglie.

Ante

Tecno, Milano, First, Brillanta, London, Narcisse.

- 1 Hi-tech
- 2 Basic

The SLIDING typology is a particular subset of Palo Alto I-Box system solutions, in which there are only Sliding doors. Some integrations among these solutions and others of the system are possible. For further information, pls see chapter INTEGRATIONS on page 105. These solutions provide 4 dimensions (height), 1 (depth) and 4 (width). Their manufacture is possible both with wooden sides and frame ones. All the sliding doors are supplied with sliding trolleys/straightening system/standard anti-collision pin. The external sliding door is supplied with a handle applied to the side opposite the opening direction. On demand it is possible to have a pair of handles.

Doors

Tecno, Milano, First, Brillanta, London, Narcisse.

- 1 Hi-tech
- 2 Basic



1



2

Tipologia aperture _ Opening typologies

SCORREVOLE _ SLIDING DOOR

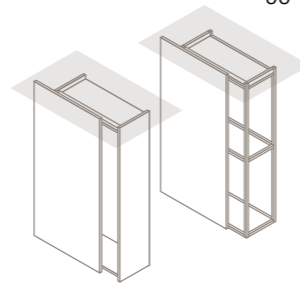

Sezioni laterali _ Side sections

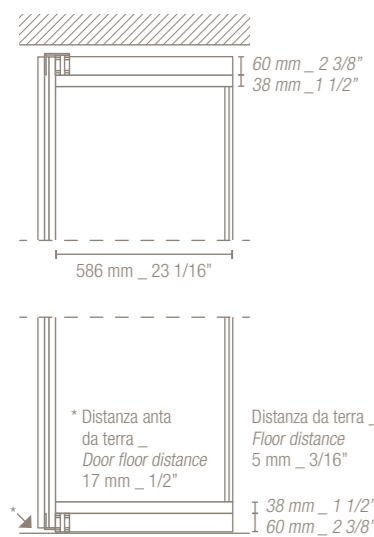

Distanza minima da soffitto _ Minimum distance from ceiling

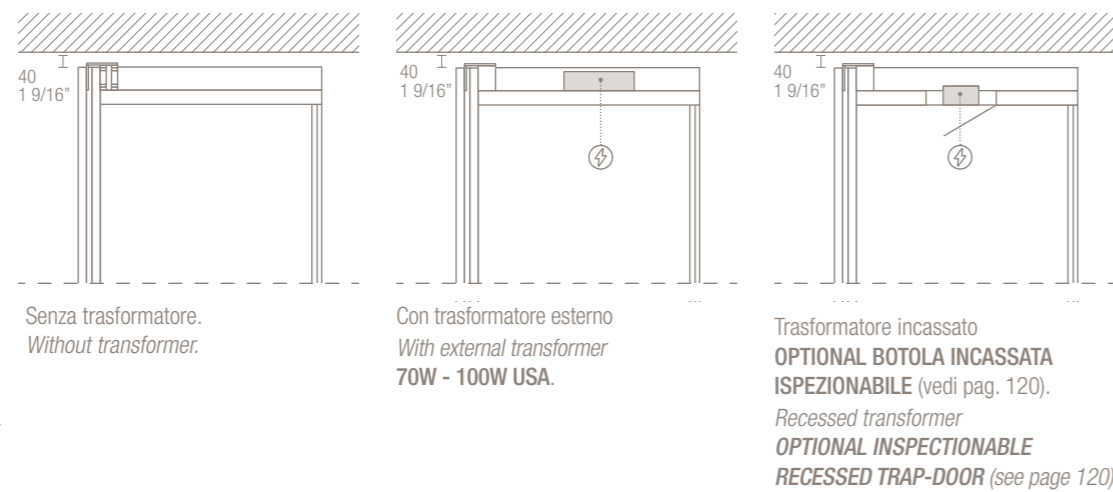

Struttura spalla legno _ Structure with wooden side panel

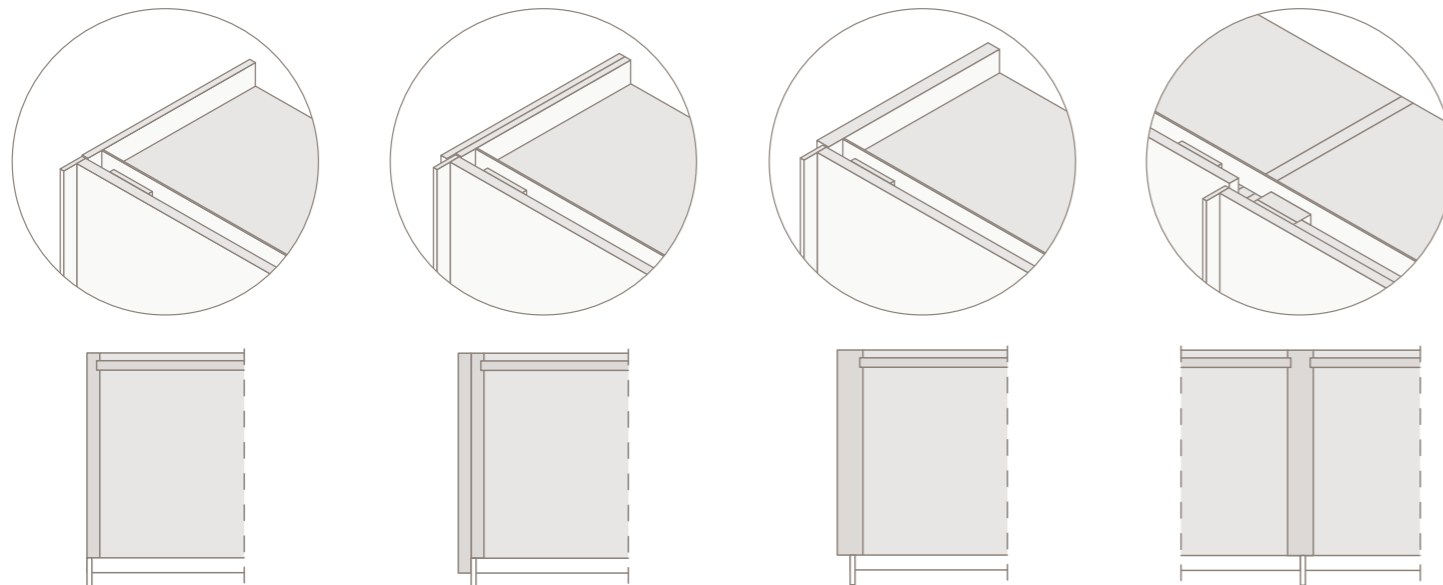

Spalla legno iniz./term.

Finiture: Interno nobilitato o laccato opaco. Esterno nobilitato, laccato opaco, laccato lucido o essenza. Sp.19 mm, P. 586 mm.

Init./term. wooden side panel

Finishings: Melamine or matt lacquered inside. Melamine, matt lacquered, glossy lacquered or wood outside. Th. 6/8", D. 23 1/8".

Sovrappalla legno

Finiture: essenza, nobilitato, lacc. opaco e lacc. lucido. Sp.19 mm. Per anta interna (optional): P. 606 mm. Per anta esterna (obbligatoria): P. 644 mm.

Finishing wooden side panel

Finis.: Wood, melamine, matt lacquered and glossy lacquered. Th. 6/8". For inside door (optional): D. 23 7/8". For external door (obligatory): D. 25 3/8".

Spalla legno iniz./term.

Finiture: Interno nobilitato o laccato opaco. Esterno nobilitato, laccato opaco, laccato lucido o essenza. Sp.38 mm, P. 586 mm.

Init./term. wooden side panel

Finis.: Melamine or matt lacquered inside. Melamine, matt lacquered, glossy lacquered or wood outside. Th. 1 1/2", D. 23 1/8".

Spalla legno centrale

Finiture: Nobilitato o laccato opaco. Sp.38 mm, P. 586 mm.

Central wooden side panel

Finishings: Melamine or matt lacquered. Th. 1 1/2", D. 23 1/8".

Struttura spalla telaio _ Structure with frame side

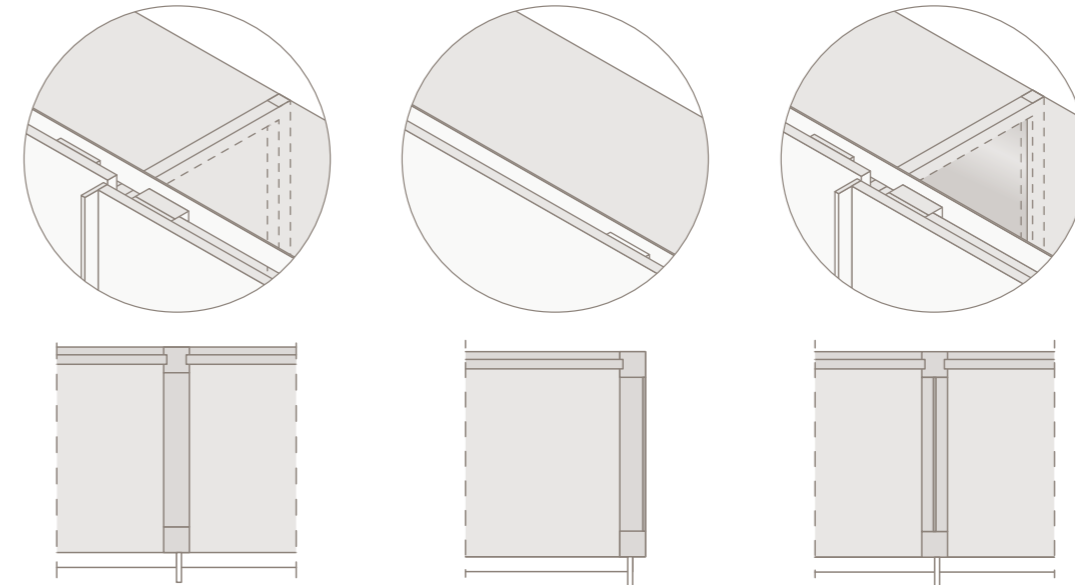

Spalla telaio centrale senza vetro

Finiture: Alluminio verniciato metallizzato. Sp.38 mm, P. 586 mm.

Central side frame without glass

Finishings: Metallic varnished aluminum. Th. 1 1/2", D. 23 1/8".

Spalla telaio iniz./term. con vetro

Finiture: Alluminio verniciato metallizzato e vetro Sp. 4mm in 12 varianti. Sp.38 mm, P. 586 mm.

Init./term. side frame with glass

Finishings: Metallic varnished aluminum and Th. 1/8" glass in 12 variants. Th. 1 1/2", D. 23 1/8".

Spalla telaio centrale con vetro

Finiture: Alluminio verniciato metallizzato e vetro Sp. 4mm in 12 varianti. Sp.38 mm, P. 586 mm.

Central side frame with glass

Finishings: Metallic varnished aluminum and Th. 1/8" glass in 12 variants. Th. 1 1/2", D. 23 1/8".

N.B.

Con ante esterne iniziali/terminali non è possibile utilizzare la spalla telaio.

N.B.

With initial/terminal external doors it is not possible to use side frame.

Posizione maniglie _ Handle positioning

Armadio scorrevole a due ante.

Di default con anta destra esterna, maniglia a destra e apertura verso sinistra. * A richiesta è possibile avere l'anta sinistra esterna con apertura verso destra e maniglia applicata a sinistra.

Sliding wardrobe with two doors.

Default supplied with external right door, handle applied on the right and opening to the left. * On request it is possible to have the left external door with opening to the right and handle applied on the left.

Armadio scorrevole a tre ante.

Di default con anta centrale esterna, apertura verso destra e maniglia a sinistra. ** È possibile richiedere l'apertura dell'anta centrale in senso opposto.

Sliding wardrobe with three doors.

Default supplied with external central door, opening to the right and handle on the left. ** It is possible to request the opening of the central door in the opposite direction.

Posizionamento maniglie _

handle positioning:

Lemma, Hook, N3, Acanto

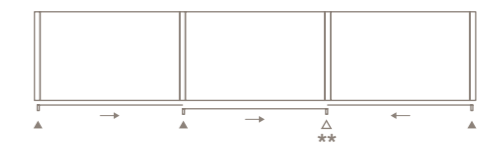
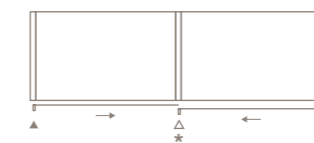

* Maniglia facoltativa, è possibile non averla. Optional handle, it is possible not to have it.

Posizionamento maniglie _

handle positioning:

Roller, Bridge, Regula, Tub Gost

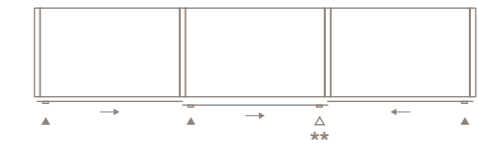
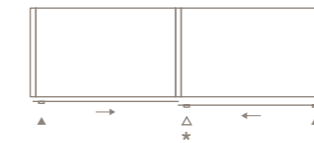

** Maniglia doppia facoltativa, su anta centrale è possibile non averla. Optional double handle, on middle sash it is possible not to have it.



Tipologia aperture _ Opening typologies

COMPLANARE _ COPLANAR DOOR

La tipologia COMPLANARE è un particolare sottoinsieme di soluzioni del sistema Palo Alto I-Box nel quale vi è solo presenza di ante Complanari. Sono possibili integrazioni fra queste soluzioni e le altre soluzioni del sistema. Per maggiori dettagli vedi capitolo INTEGRAZIONI pag. 105. Queste soluzioni prevedono 4 dimensioni in altezza, 1 in profondità, 3 in larghezza e sono realizzabili sia con le spalle legno, sia con spalle telaio. Tutte le ante complanari sono fornite con sistema di scorrimento complanare ammortizzato e con raddrizzante.

Ante

Tecno, Milano, First, Brillanta, London, Narcisse.

- 1 Hi-tech
- 2 Basic

The SLIDING typology is a particular subset of Palo Alto I-Box system solutions, in which there are only Sliding doors. Some integrations among these solutions and others of the system are possible. For further information, pls see chapter INTEGRATIONS on page 105. These solutions provide 4 dimensions (height), 1 (depth) and 3 (width). Their manufacture is possible both with wooden sides and frame ones. All the coplanar doors are supplied with a coplanar soft closing system and a straightening one.

Doors

Tecno, Milano, First, Brillanta, London, Narcisse.

- 1 Hi-tech
- 2 Basic



1



2

Tipologia aperture _ Opening typologies

COMPLANARE _ COPLANAR DOOR

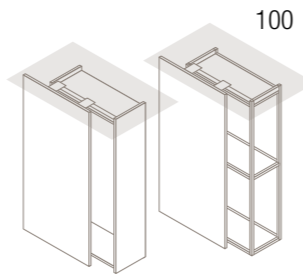

100

Sezioni laterali _ Side sections

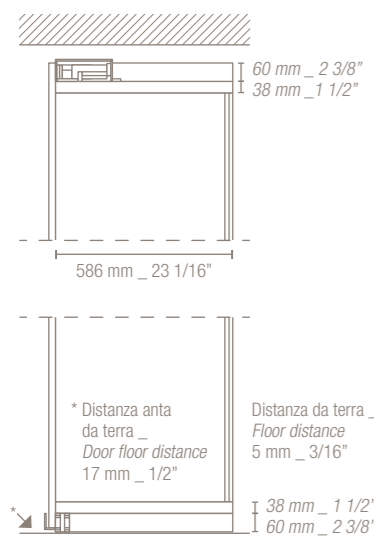

Meccanismo light _ Light mechanism

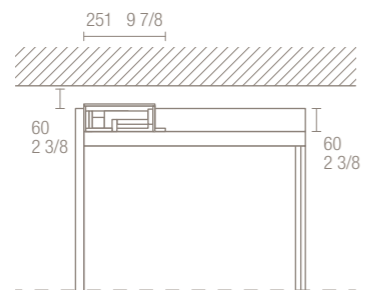

Senza trasformatore.
Without transformer.

Distanza minima da soffitto _ Minimum distance from ceiling

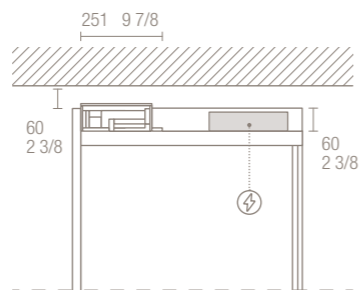

Con trasformatore esterno
With external transformer
70W - 100W USA.

Distanza minima da soffitto _ Minimum distance from ceiling

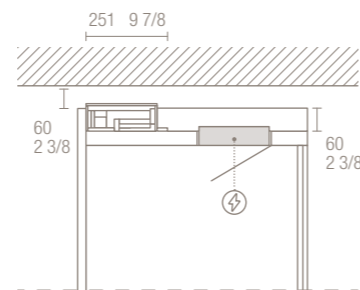

Trasformatore incassato
OPTIONAL BOTOLA INCASSATA ISPEZIONABILE (vedi pag. 120).
Recessed transformer
OPTIONAL INSPECTIONABLE RECESSED TRAP-DOOR (see page 120).

Meccanismo strong _ Strong mechanism

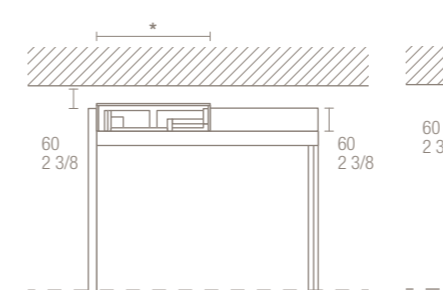

Senza trasformatore.
Without transformer.

Distanza minima da soffitto _ Minimum distance from ceiling

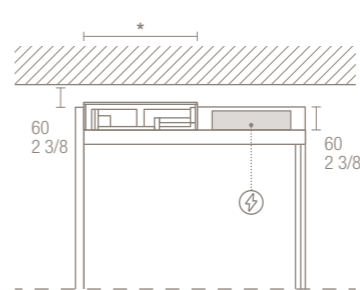

Con trasformatore esterno
With external transformer
70W - 100W USA.

Distanza minima da soffitto _ Minimum distance from ceiling

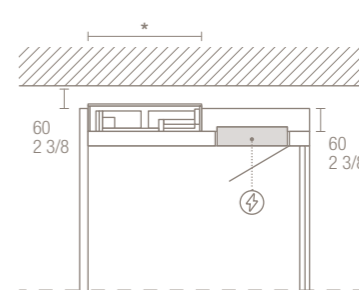

Trasformatore incassato
OPTIONAL BOTOLA INCASSATA ISPEZIONABILE (vedi pag. 120).
Recessed transformer
OPTIONAL INSPECTIONABLE RECESSED TRAP-DOOR (see page 120).

* 2 ante_doors
L 329 mm 12 15/16"
3 ante_doors
L 334 mm 13 1/8"

Struttura spalla legno _ Structure with wooden side panel

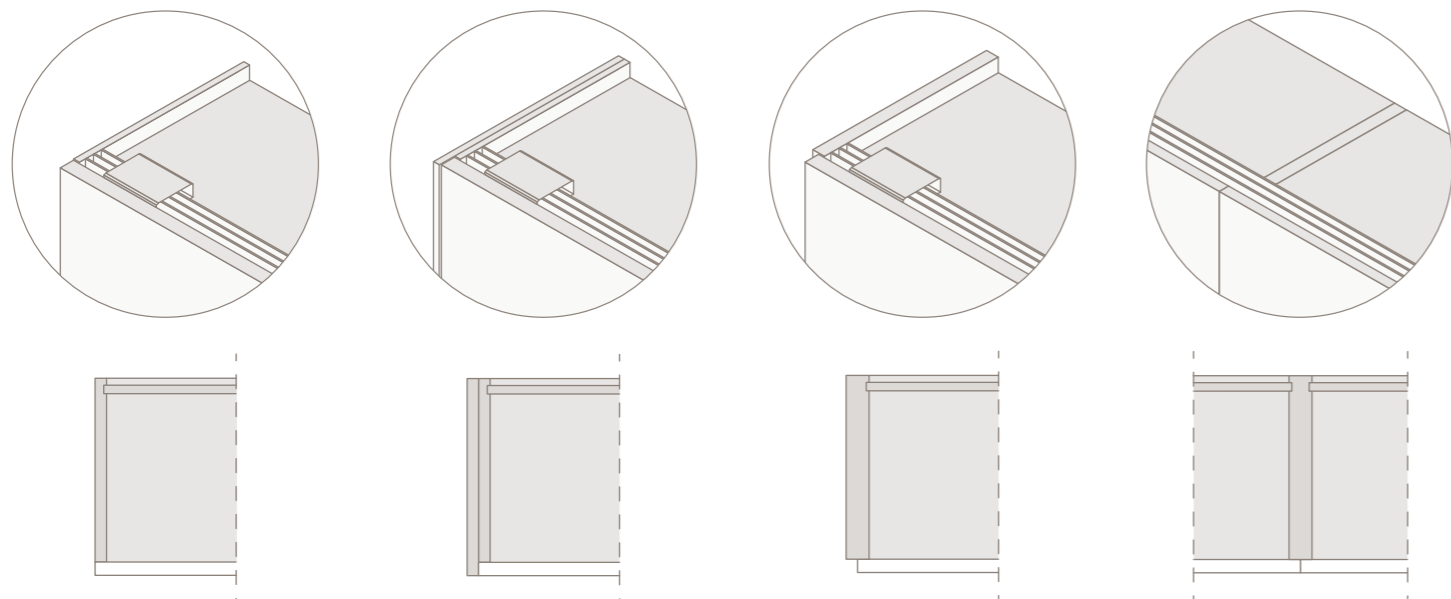

Spalla legno iniz./term.

Finiture: Interno nobilitato o laccato opaco. Esterno nobilitato, laccato opaco, laccato lucido o essenza. Sp.19 mm, P. 586 mm.

Init./term. wooden side panel

Finishings: Melamine or matt lacquered inside. Melamine, matt lacquered, glossy lacquered or wood outside. Th. 6/8", D. 23 1/8".

Sovrappalla legno (optional)

Finiture: essenza, nobilitato, laccato opaco e laccato lucido. Sp.19 mm, P. 606 mm.

Finishing wooden side panel (opt.)

Finishings: Wood, melamine, matt lacquered and glossy lacquered. Th. 6/8", D. 23 7/8".

Spalla legno iniz./term.

Finiture: Interno nobilitato o laccato opaco. Esterno nobilitato, laccato opaco, laccato lucido o essenza. Sp.38 mm, P. 586 mm.

Init./term. wooden side panel

Finishings: Melamine or matt lacquered inside. Melamine, matt lacquered, glossy lacquered or wood outside. Th. 1 1/2", D. 23 1/8".

Spalla legno centrale

Finiture: Nobilitato o laccato opaco. Sp.38 mm, P. 586 mm.

Central wooden side panel

Finishings: Melamine or matt lacquered. Th. 1 1/2", D. 23 1/8".

Struttura spalla telaio _ Structure with frame side

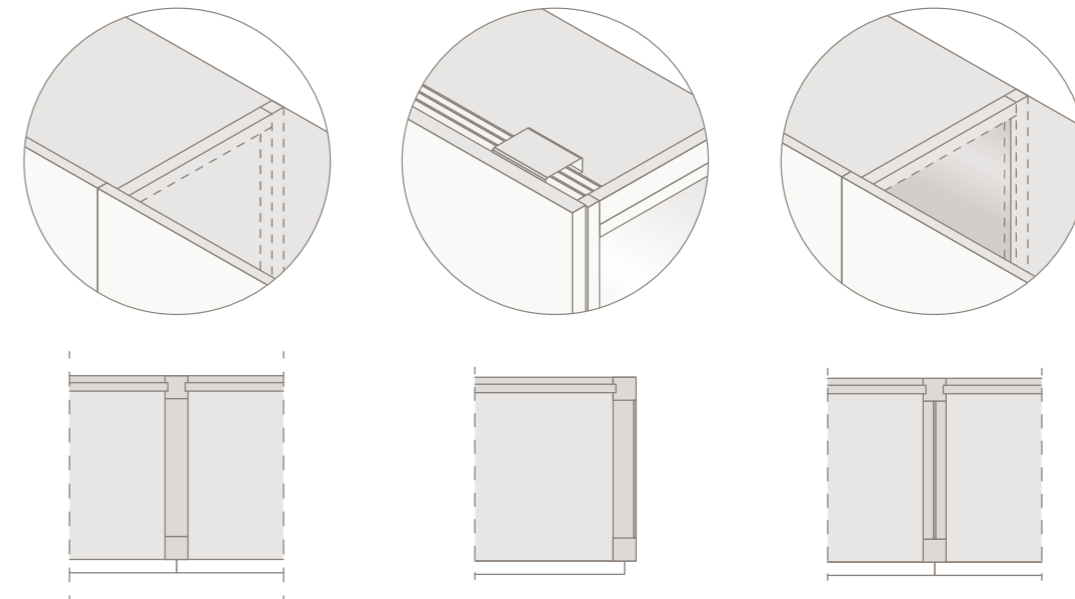

Spalla telaio centrale senza vetro

Finiture: Alluminio verniciato metallizzato. Sp.38 mm, P. 586 mm.

Central side frame without glass

Finishings: Metallic varnished aluminum. Th. 1 1/2", D. 23 1/8".

Spalla telaio iniz./term. con vetro

Finiture: Alluminio verniciato metallizzato e vetro Sp. 4mm in 12 varianti. Sp.38 mm, P. 586 mm.

Init./term. side frame with glass

Finishings: Metallic varnished aluminum and Th. 1/8" glass in 12 variants. Th. 1 1/2", D. 23 1/8".

Spalla telaio centrale con vetro

Finiture: Alluminio verniciato metallizzato e vetro Sp. 4mm in 12 varianti. Sp.38 mm, P. 586 mm.

Central side frame with glass

Finishings: Metallic varnished aluminum and Th. 1/8" glass in 12 variants. Th. 1 1/2", D. 23 1/8".

Tipologia aperture _ Opening typologies

COMPLANARE _ COPLANAR DOOR

Posizione maniglie _ Handle positioning

Armadio complanare a due ante.

La riduzione in larghezza dell'armadio si ottiene riducendo i 2 moduli della stessa dimensione, con le ante ridotte in larghezza fino a un minimo di L800 mm e non oltre.

Coplanar wardrobe with two doors.

The width reduction of the wardrobe is achieved by reducing the 2 modules of the same size, with the doors reduced in width up to a minimum of Th. 31 1/2 and not beyond.

Armadio complanare a tre ante.

La riduzione in larghezza dell'armadio si ottiene riducendo i 3 moduli della stessa dimensione, con le ante ridotte in larghezza fino a un minimo di L800 mm e non oltre.

Coplanar wardrobe with three doors.

The width reduction of the wardrobe is achieved by reducing the 3 modules of the same size, with the doors reduced in width up to a minimum of Th. 31 1/2 and not beyond.

Di default le maniglie sono posizionate come da disegno _ By default the handles are positioned as shown in the drawing

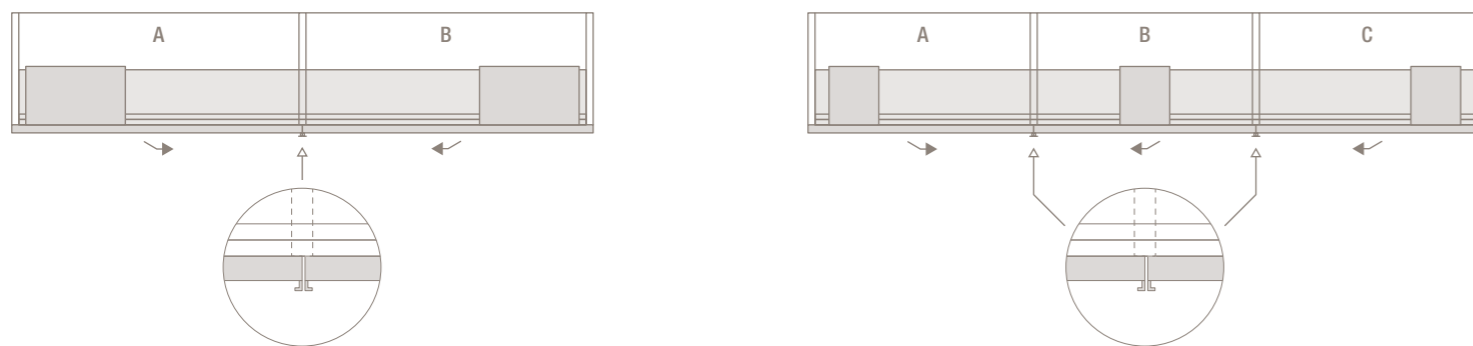

Modalità aperture ante armadio complanare a due o tre ante _ Doors opening modality for coplanar wardrobe with two or three doors

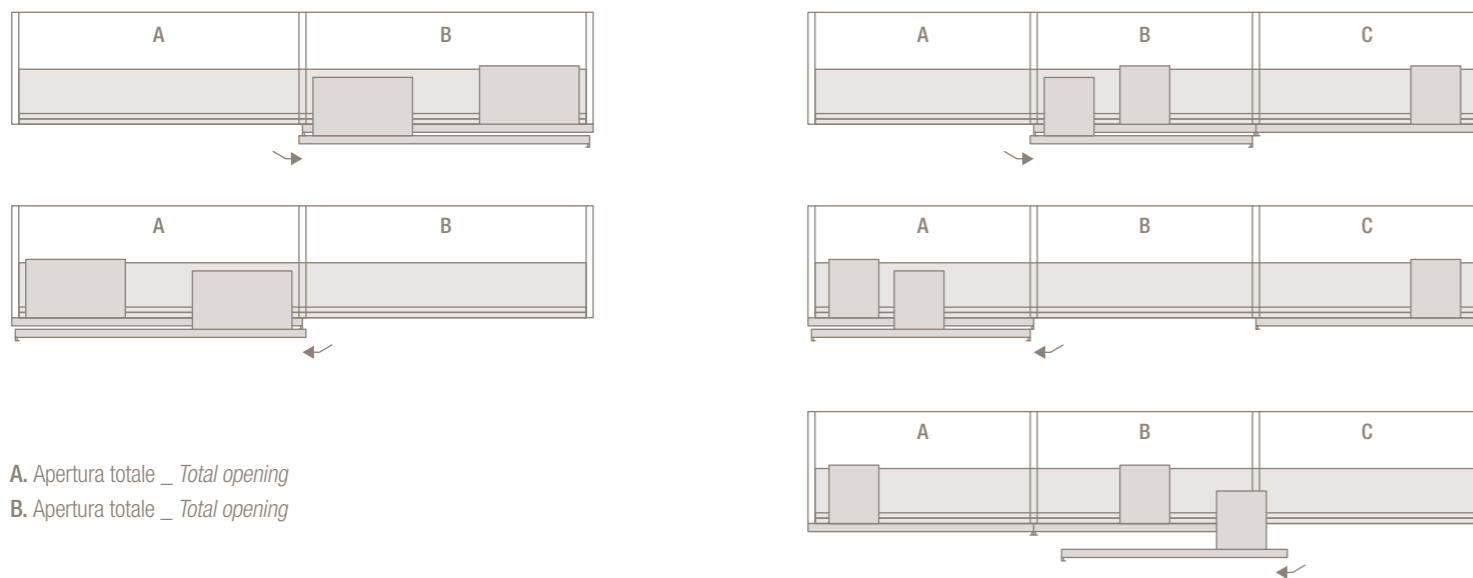

A. Apertura totale _ Total opening

B. Apertura parziale _ Partial opening

A. Apertura totale _ Total opening

B. Apertura totale _ Total opening

C. Apertura parziale _ Partial opening

Nel modulo C non è possibile inserire cassettiere e ripiani estraibili
In module C it is not possible to insert drawers and removable shelves





Integrazioni tra tipologie di apertura _ Integrations between opening types

ALLINEAMENTO TRA ARMADIO BATTENTE E ARMADIO SCORREVOLE/COMPLANARE _ HINGED DOOR AND SLIDING/COPLANAR ALIGNMENT

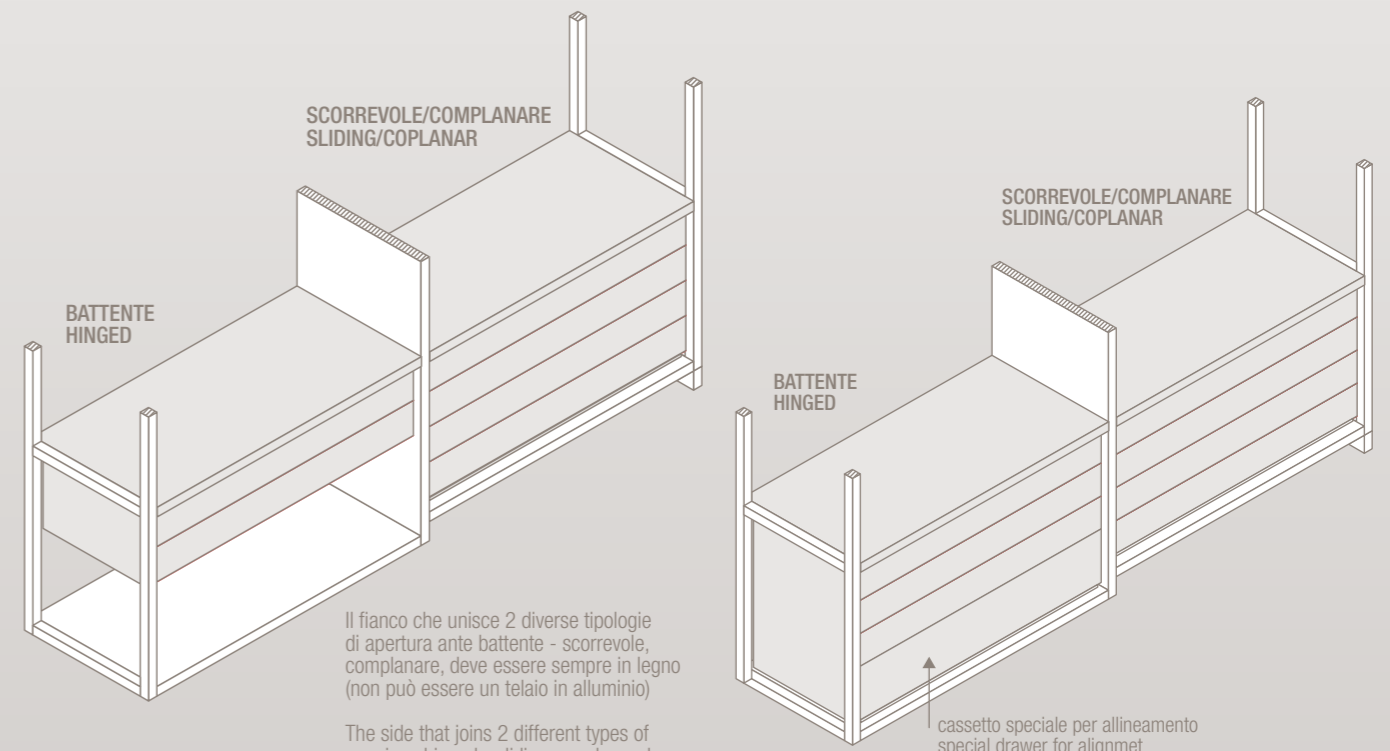
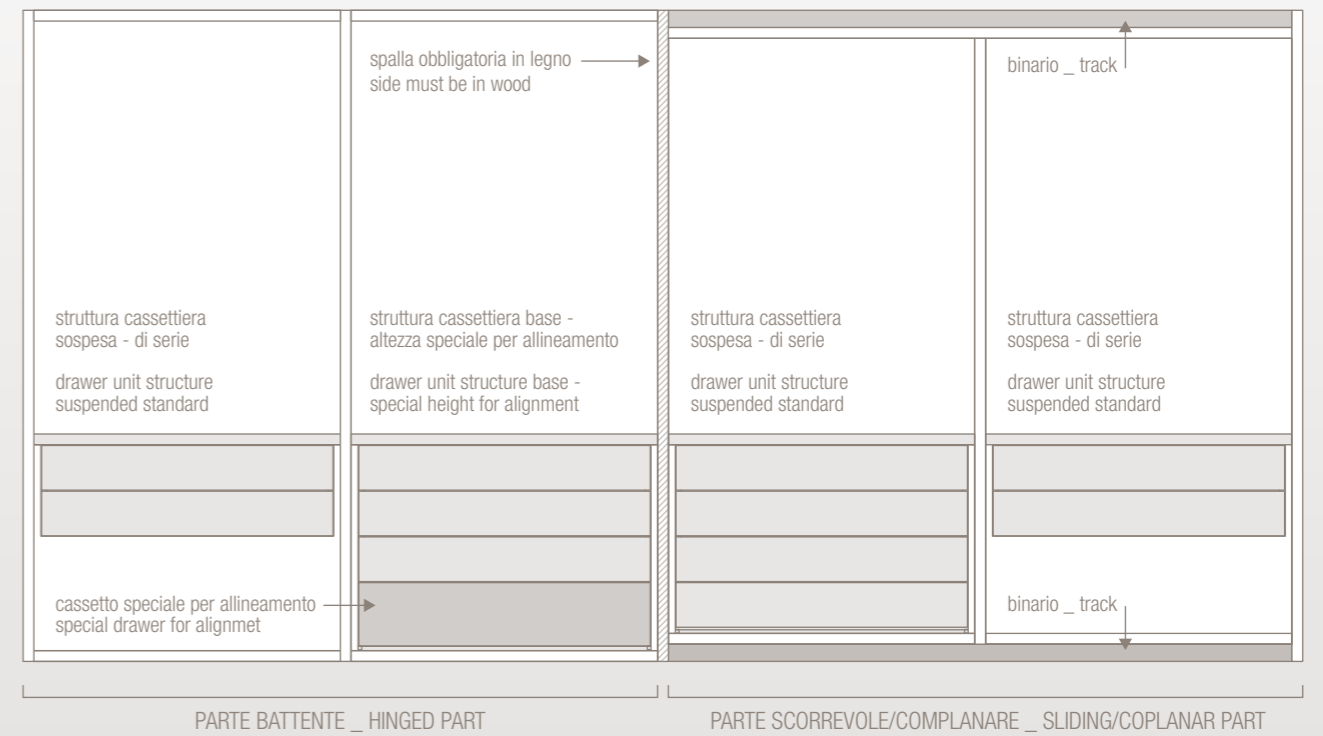

Il fianco che unisce 2 diverse tipologie di apertura ante battente - scorrevole, coplanare, deve essere sempre in legno (non può essere un telaio in alluminio)

The side that joins 2 different types of openings hinged - sliding - coplanar door must always be in wood (it cannot be an aluminium frame)

Accessori e dettagli struttura _ *Accessories and structure details*



Accessori e dettagli struttura _ Accessories and structure details

ACCESSORI STRUTTURALI DI SERIE _ STANDARD STRUCTURE ACCESSORIES



TAPPINO

Tappino a copertura delle viti di giunzione fra basamento/coperchio e le spalle. La finitura del tappino è in abbinamento con la finitura della struttura.

CAPS

Cap covering the junction screws between the base/cover and the shoulders. The finish of the cap is in combination with the finish of the structure.



PROFILO ANTI-POLVERE

Montato su tutti i coperchi e basamenti protegge gli interni e garantisce una chiusura ammortizzata delle ante.

ANTI-DUST PROFILE

Mounted on all wardrobes tops and bases, it protects inner parts and guarantees doors soft-closing.

ABBINAMENTO SPALLE LEGNO E SCHIENALI _ WOODEN SIDE PANELS AND BACK PANELS COMBINATION



1. Spalle legno - Schienale legno _ Wood side panel - Wood back panel
2. Spalle legno - Schienale vetro _ Wood side panel - Glass back panel
3. Spalle legno - Schienale tecno-marble _ Wood side panel - Tecno-marble back panel

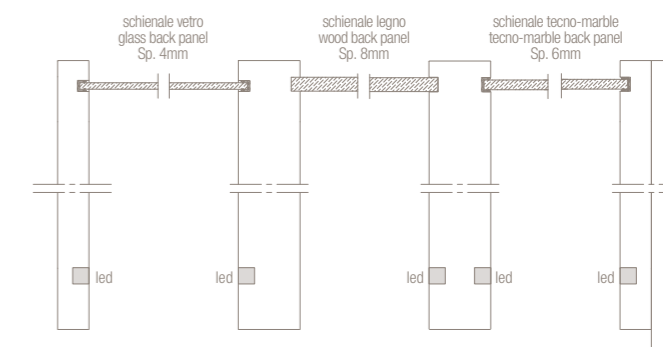

Finiture Schienale _ Back panel finishings



Per dettaglio finiture vedi Capitolo pag. 75 _ For finishing detail see page 75



Accessori e dettagli struttura _ Accessories and structure details

ABBINAMENTO SPALLE TELAIO SENZA VETRO E SCHIENALI _ SIDE FRAME WITHOUT GLASS AND BACK PANELS COMBINATION



1. Spalle telaio senza vetro - Schienale legno _ Frame side without glass - Wood back panel
2. Spalle telaio senza vetro - Schienale vetro _ Frame side without glass - Glass back panel
3. Spalle telaio senza vetro - Schienale tecno-marble _ Frame side without glass - Tecno-marble back panel

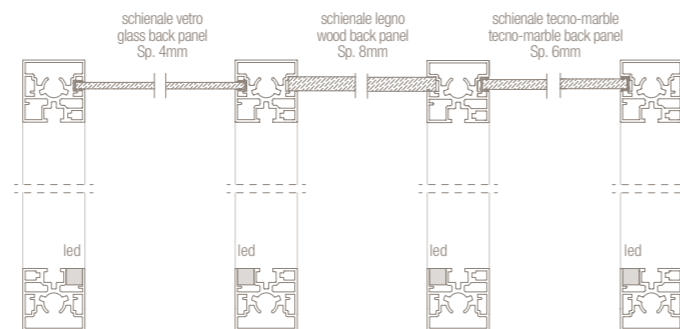

Finiture Schienale _ Back panel finishings

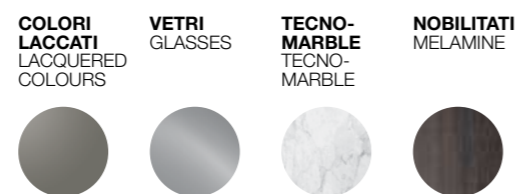

Per dettaglio finiture vedi Capitolo pag. 75 _ For finishing detail see page 75



ABBINAMENTO SPALLE TELAIO CON VETRO E SCHIENALI _ SIDE FRAME WITH GLASS AND BACK PANELS COMBINATION



1. Spalle telaio con vetro - Schienale legno _ Frame side with glass - Wood back panel
2. Spalle telaio con vetro - Schienale vetro _ Frame side with glass - Glass back panel
3. Spalle telaio con vetro - Schienale tecno-marble _ Frame side with glass - Tecno-marble back panel

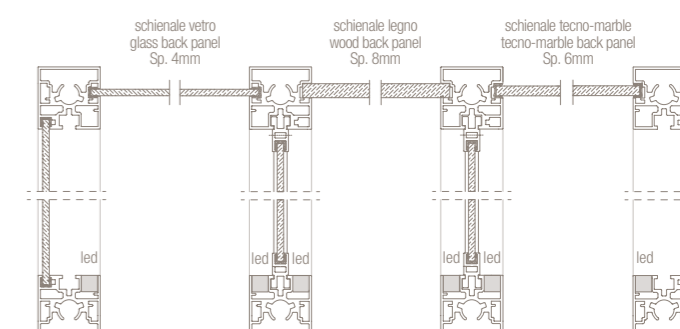

Finiture Schienale _ Back panel finishings



Per dettaglio finiture vedi Capitolo pag. 75 _ For finishing detail see page 75



Accessori e dettagli struttura _ Accessories and structure details

SPALLE LEGNO FORATURA DISEGNO _ WOODEN SIDES – DRAWING PUNCTURE



Foratura A DISEGNO passo 80mm.

Foratura solo in corrispondenza dei ripiani e delle attrezzature, mantenendo passo 80 mm. Consente una maggiore pulizia visiva.

DRAWING puncture allow 3 1/8"

Puncture only at the shelves and equipments, maintaining Th. 3 1/8" It allows greater visual cleaning.

1. Battente P. 380 mm _ *Hinged door D. 15"*
2. Battente P. 586 mm _ *Hinged door D. 23 1/8"*
3. Scorrevole P. 586 mm _ *Sliding door D. 23 1/8"*
4. Complanare P. 586 mm _ *Coplanar door D. 23 1/8"*

* posizione portascarpe fuori passo per allineamento a ripiani/cassettera.
shoe-rack position for a shelf/chest of drawer alignment

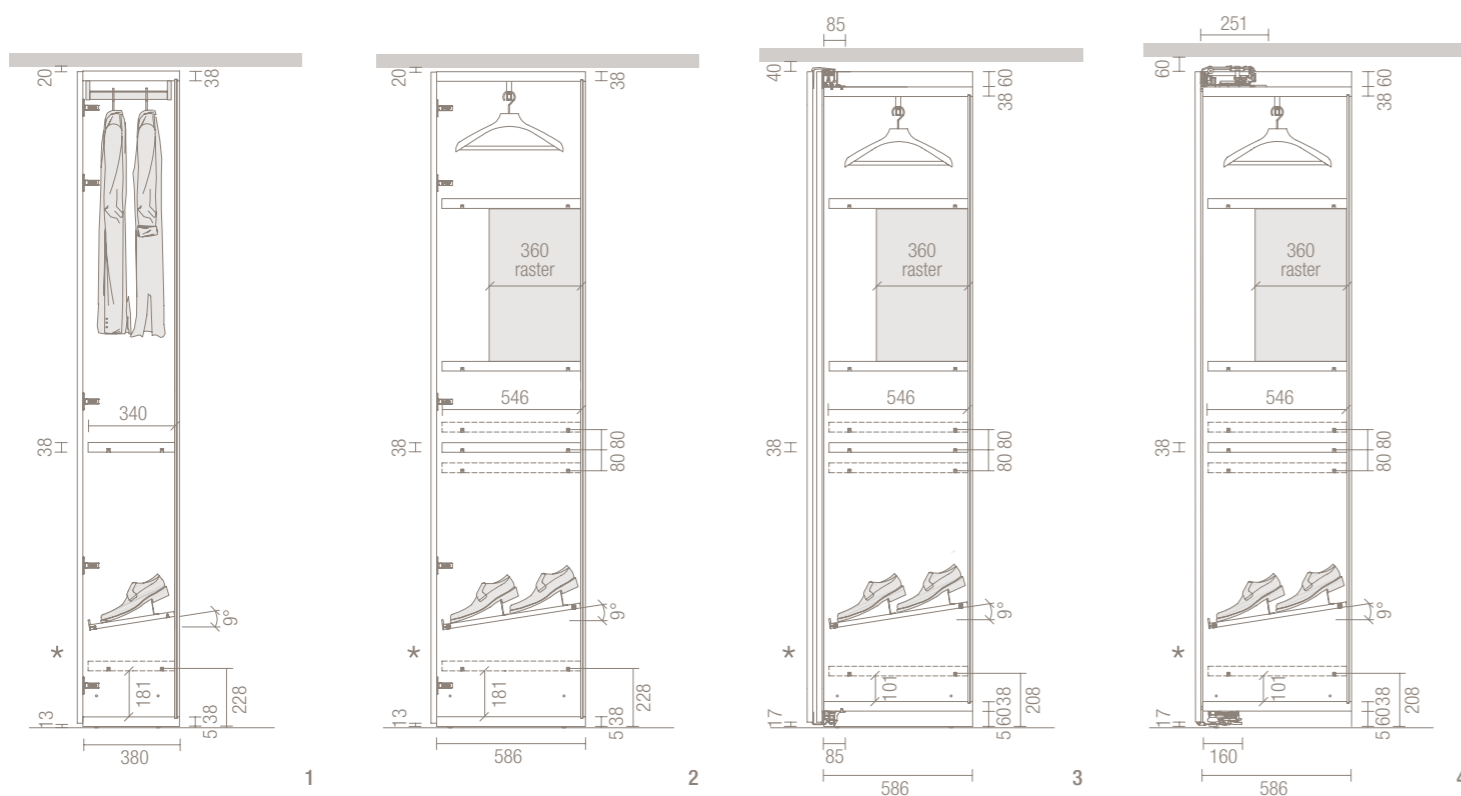

SPALLE LEGNO FORATURA FITTING _ WOODEN SIDES – FITTING PUNCTURE



Foratura Ø 3 mm FITTING passo 80mm.

Consente lo spostamento dei ripiani ogni 80 mm.

Ø 1/8" FITTING puncture 3 1/8"

FITTING allowing shelf displacement.

1. Battente P. 380 mm _ *Hinged door D. 15"*
2. Battente P. 586 mm _ *Hinged door D. 23 1/8"*
3. Scorrevole P. 586 mm _ *Sliding door D. 23 1/8"*
4. Complanare P. 586 mm _ *Coplanar door D. 23 1/8"*

* posizione portascarpe fuori passo per allineamento a ripiani/cassettera.
shoe-rack position for a shelf/chest of drawer alignment.

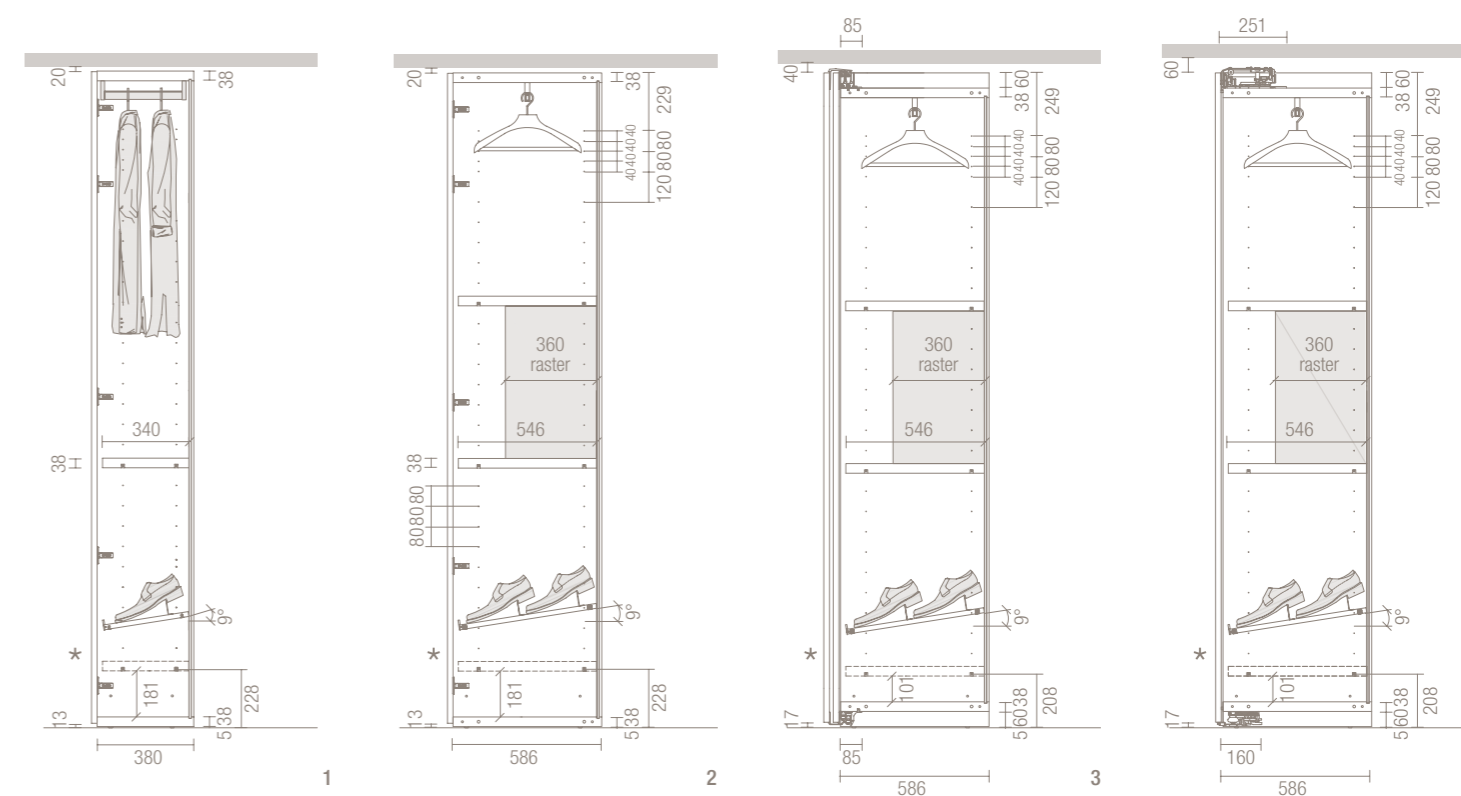

Accessori e dettagli struttura _ Accessories and structure details

SPALLE TELAIO _ SIDE FRAME



Tramite un sistema di regolazione continua a coda di rondine, è possibile un posizionamento dei ripiani al millimetro sulla spalla telaio alluminio. Qualora ci fosse un ripiano tra spalla legno e spalla telaio è possibile allinearsi al passo di foratura delle spalle legno mediante traversi oppure supporti applicati al telaio.

By means of a continuous dovetail adjustment system, it is possible to position the shelves to the millimeter on the aluminum frame side. If there is a shelf between the wooden side panel and the frame side it is possible to align with the drilling step of the wooden side panel using crosspieces or supports applied to the frame.

1. Battente P. 380 mm _ Hinged door D. 15"
2. Battente P. 586 mm _ Hinged door D. 23 1/8"
3. Scorrevole P. 586 mm _ Sliding door D. 23 1/8"
4. Complanare P. 586 mm _ Coplanar door D. 23 1/8"

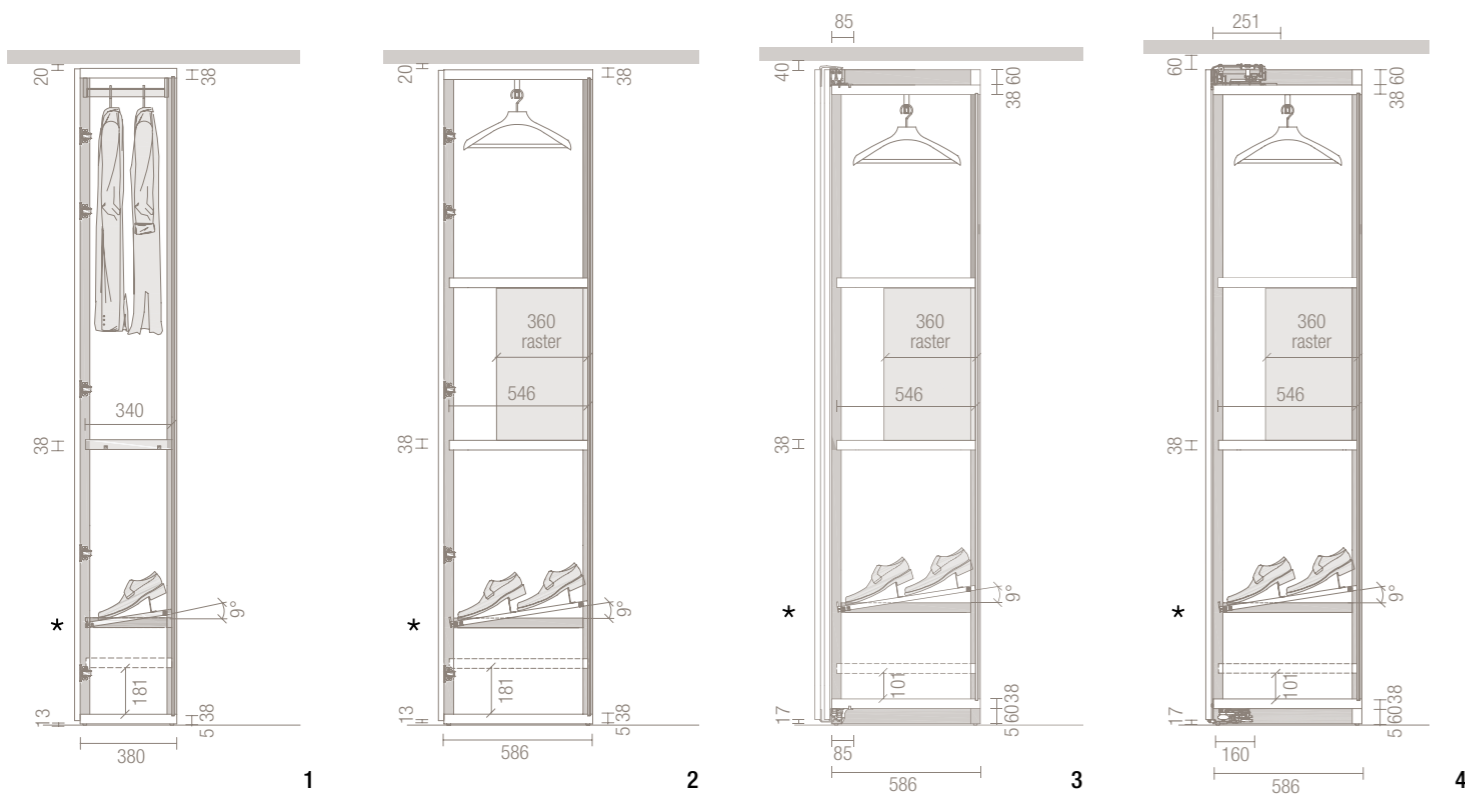

Focus On

TIPOLOGIE TRAVERSI E SUPPORTI PER RIPIANI DELLE SPALLE TELAIO _ SUPPORT TYPOLOGIES FOR FRAME SIDES

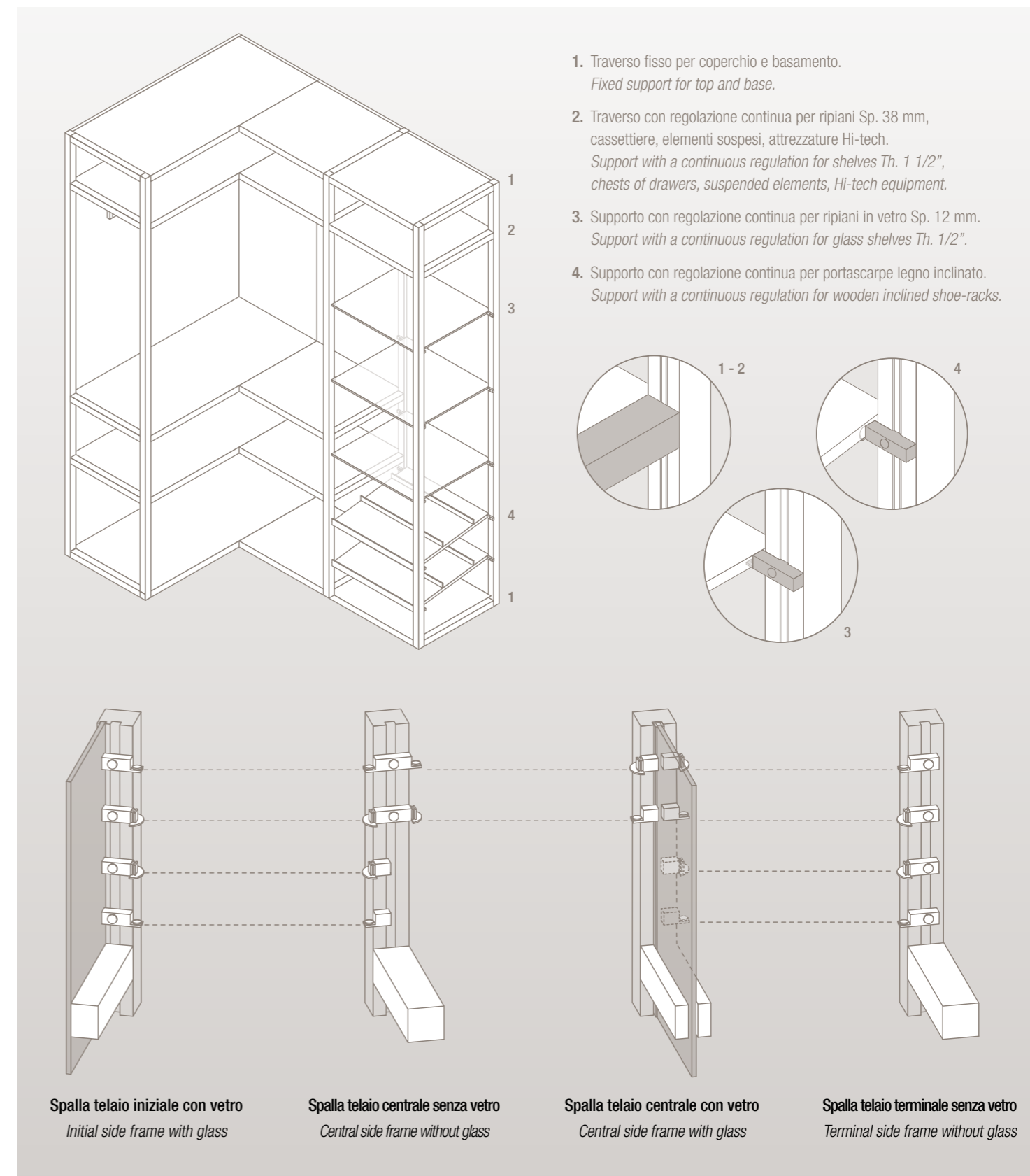

Accessori e dettagli struttura _ Accessories and structure details**CERNIERE SPALLA LEGNO _ WOOD SIDE PANEL HINGE**

1. Cerniera in metallo verniciato Canna di Fucile per tutte le ante escluso ante **Narcisse, Zeus e Rex**. Apertura di serie 110°, opzionale 155°.
*Hinge in Gunmetal varnished for all doors except **Narcisse, Zeus and Rex** doors. Standard opening 110°, optional 155°.*
2. Cerniera **Narcisse** - Cerniera in metallo verniciato Canna di Fucile esclusiva per ante **Narcisse e Zeus**. Apertura di serie 98°.
***Narcisse** hinge - Hinge in Gunmetal varnished only for **Narcisse and Zeus** doors. Standard opening 98°.*
3. Cerniera **Rex** - Cerniera in metallo verniciato Canna di Fucile esclusiva per ante **Rex** Apertura di serie 180°.
***Rex** hinge - Hinge in Gunmetal varnished metal only for **Rex** door. Standard opening 180°.*

**CERNIERE SPALLA TELAIO _ FRAME SIDE HINGE**

1. Cerniera in metallo verniciato Canna di Fucile per tutte le ante escluso ante **Narcisse, Zeus e Rex**. Apertura di serie 110°.
*Hinge in Gunmetal varnished for all doors except **Narcisse, Zeus and Rex** doors. Standard opening 110°.*
2. Cerniera **Narcisse** - Cerniera in metallo verniciato Canna di Fucile esclusiva per ante **Narcisse e Zeus**. Apertura di serie 98°.
***Narcisse** hinge - Hinge in Gunmetal varnished only for **Narcisse and Zeus** doors. Standard opening 98°.*
3. Cerniera **Rex** - Cerniera in metallo verniciato Canna di Fucile esclusiva per ante **Rex** Apertura di serie 180°.
***Rex** hinge - Hinge in Gunmetal varnished metal only for **Rex** door. Standard opening 180°.*



Impianto illuminazione _ *Lighting system*



Impianto illuminazione _ Lighting system

COMPONENTI IMPIANTO ILLUMINAZIONE _ LIGHTING SYSTEM COMPONENTS



1. Botola _ Trap Door

Vano porta trasformatori, costituito da una scatola di alluminio verniciata nera metallizzata dotata di pannello apribile, ispezionabile dall'interno dell'armadio. Il vano porta trasformatori è situato sul coperchio del modulo del sistema.

Transforming case characterized by a metal aluminum varnished box supplied with an opening panel from the inside part of the wardrobe. The transforming display case is located on the top of the module.

2. Sensore di movimento temporizzato _ Time moving detector

È possibile dotare il sistema, solo nella soluzione ad ante battenti, scorrevoli o coplanari, di un sensore di movimento temporizzato, che attiva l'impianto di illuminazione all'apertura dell'anta.

Only in the solution with hinged doors, sliding doors, or coplanar ones, it is possible to supply the system with a time moving detector activating the time-release lighting plant when the door is open.

3. Kit Radio-Comando _ Remote-Control Kit

È possibile dotare l'impianto di illuminazione di un kit Radio-comando per poter attivare o disattivare l'impianto di illuminazione del sistema con Radio-comando. È possibile allacciare l'impianto di illuminazione direttamente all'interruttore della stanza, senza quindi l'ausilio di un radio-comando o di sensori di movimento.

Transforming case characterized by a metal aluminum varnished box supplied with an opening panel from the inside part of the wardrobe. It is possible to directly connect the lighting plant to the switch in the room; therefore, without any remote control or moving detectors.



Focus On

PASSAGGIO CAVI _ WIRE PASSAGE

Passaggio cavi LED orizz./vert. con schienale legno Horiz./vert. LED wire passage with wooden back panel

1. Luce LED orizzontale nel ripiano _ Horizontal LED light in the shelf
2. Luce LED orizzontale nel coperchio _ Horizontal LED light in the top
3. Foro di uscita filo LED su coperchio _ LED wire exit hole on the top
4. Luce LED verticale nella spalla telaio/legno _ Vertical LED light in the wooden/frame side panel
5. Spalla telaio/legno _ Wooden/frame side panel
6. Foro di uscita filo LED schienale legno _ LED wire exit hole on the wooden back panel
7. Schienale legno _ Wooden back panel

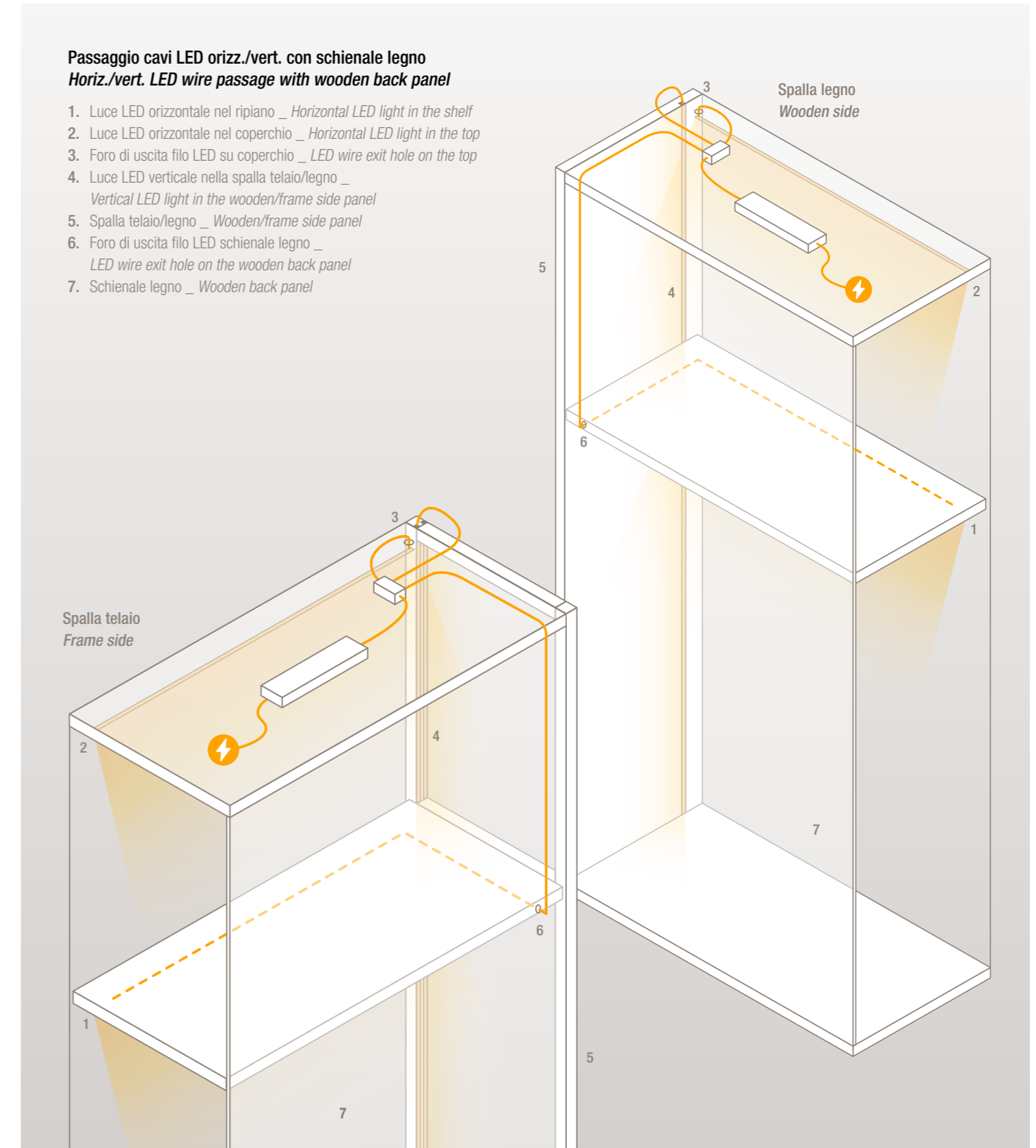

Focus On

PASSAGGIO CAVI _ WIRE PASSAGE

Passaggio cavi LED orizz./vert. con schienale vetro o tecno-marble
Horiz./vert. LED wire passage with glass or tecno-marble back panel

Con schienale vetro o tecno-marble non è possibile applicare luce LED nel ripiano
It is not possible to apply LED light in the shelf with glass or tecno-marble back panel

1. Luce LED orizzontale nel coperchio _ Horizontal LED light in the top
2. Foro di uscita filo LED su coperchio _ LED wire exit hole on the top
3. Luce LED verticale nella spalla telaio/legno _ Vertical LED light in the wooden/frame side panel
4. Spalla telaio/legno _ Wooden/frame side panel
5. Schienale vetro o tecno-marble _ Glass or tecno-marble back panel

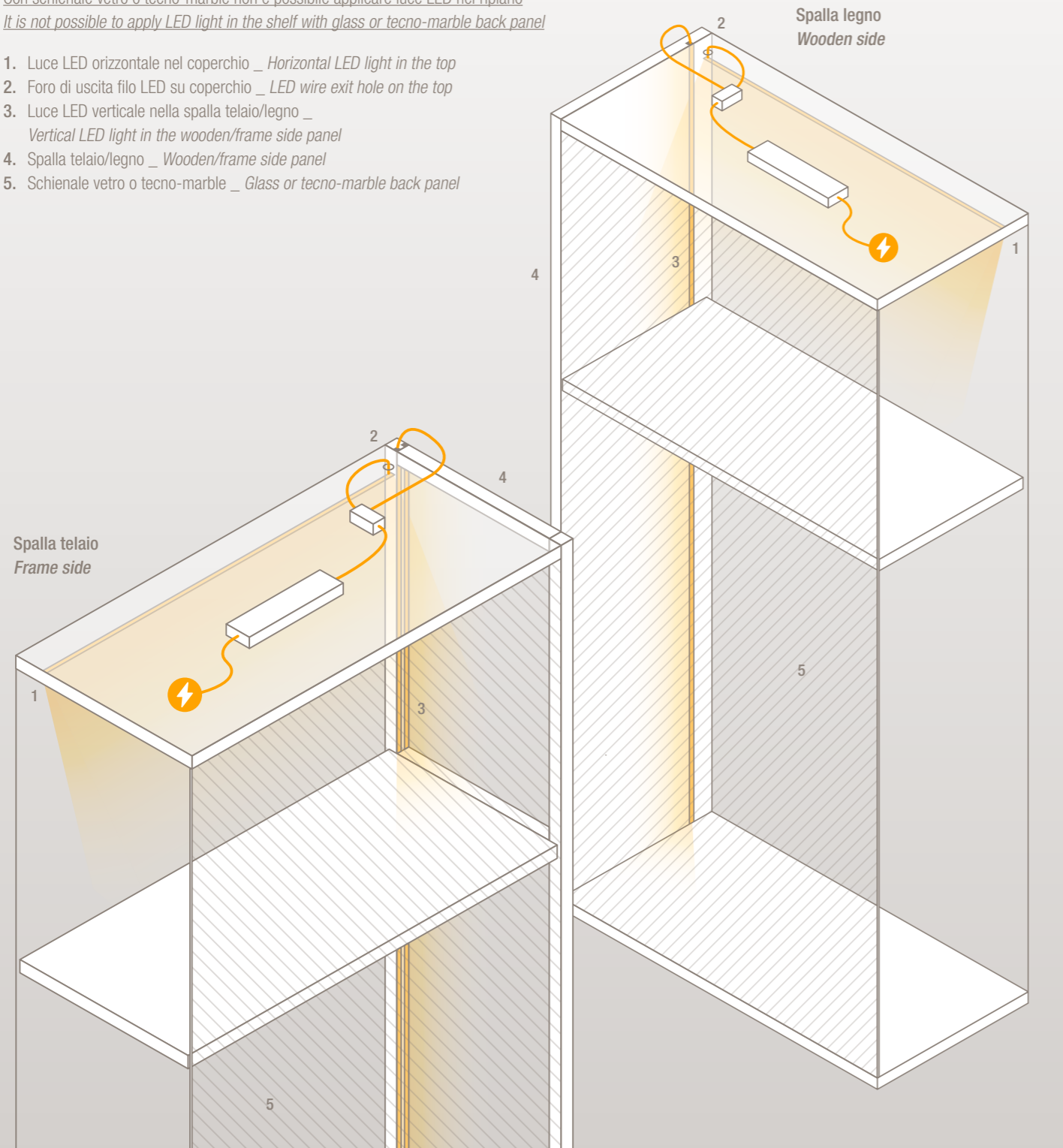
**Impianto illuminazione _ Lighting system**

LUCI LED ZAFFIRO ORIZZONTALE _ HORIZONTAL LED LIGHT ZAFFIRO

**Luce LED ZAFFIRO orizzontale per coperchi e ripiani legno o ecopelle**

Luce LED incassata nel ripiano/coperchio orizzontale, completo di cablaggio per collegamento. Lampade a gradazione calda 3000° K, a luce bianca 110 V o 220 V. Collegabili a dispositivo radio-comando, sensore oppure interruttore della stanza. Disponibili anche per ripiani di elementi terminali ad angolo. Non è possibile inserire le lampade LED orizzontali per ripiani in presenza di schienali vetro.

Horizontal LED LIGHT ZAFFIRO for wooden or eco-leather shelves

Inserted LED light in the horizontal shelf/top supplied with a linking cable. Warm 3000K shade, 110 V or 220 V white lights. Connecting to a remote control or a detector or a switch in the room. Also available for the shelves of corner terminal elements. It is not possible to insert horizontal LED lights for shelves with glass back panels.

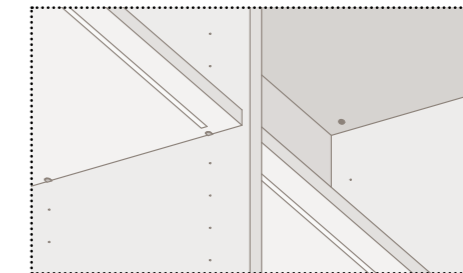
**Luce LED ZAFFIRO orizzontale per ripiani frame**

Luce LED incassata nel ripiano orizzontale, completo di cablaggio per collegamento. Lampade a gradazione calda 3000° K, a luce bianca 110 V o 220 V. Collegabili a dispositivo radio-comando, sensore oppure interruttore della stanza. Disponibili anche per ripiani di elementi terminali ad angolo. Non è possibile inserire le lampade LED orizzontali per ripiani in presenza di schienali vetro.

Horizontal LED LIGHT ZAFFIRO for wooden shelves

Inserted LED light in the horizontal shelf/top supplied with a linking cable. Warm 3000K shade, 110 V or 220 V white lights. Connecting to a remote control or a detector or a switch in the room. Also available for the shelves of corner terminal elements. It is not possible to insert horizontal LED lights for shelves with glass back panels.

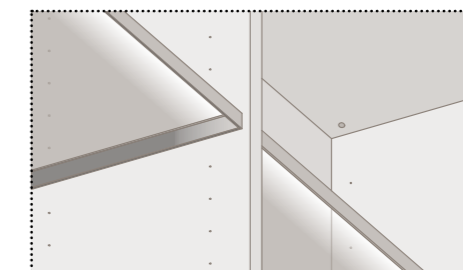

Impianto illuminazione _ *Lighting system*

LUCE LED ZAFFIRO VERTICALE PER SPALLE LEGNO _ *VERTICAL LED LIGHT FOR WOODEN SIDE PANELS*



Luce LED ZAFFIRO verticale per spalla legno

Luce LED incassata nella spalla legno verticale, completo di cablaggio per collegamento. Lampade a gradazione calda 3000° K, a luce bianca 110 V o 220 V. Collegabili a dispositivo radio-comando o sensore o interruttore della stanza. Per spalla legno iniziale/terminale max 1 luce. Per spalla legno centrale max 2 luci.

Vertical LED LIGHT ZAFFIRO for wooden side panel

Inserted LED light in the horizontal shelf/top supplied with a linking cable. Warm 3000K shade, 110 V or 220 V white lights. Connecting to a remote control or a detector or a switch in the room. As far as the initial/terminal side is concerned No. light: max 1. For the central wooden side panel No. lights: max 2.

Area illuminata _ Lighted area

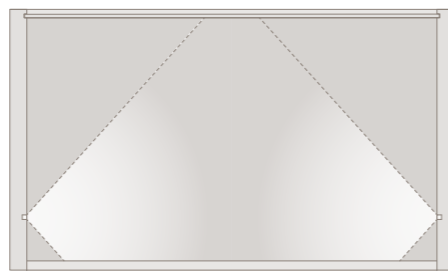

Luce LED ZAFFIRO verticale con carter per spalla legno

Luce LED incassata nella spalla legno verticale, completo di cablaggio per collegamento. Lampade a gradazione calda 3000° K, a luce bianca 110 V o 220 V. Collegabili a dispositivo radio-comando o sensore o interruttore della stanza. Per spalla legno iniziale/terminale Nr. 1 luce. Per spalla legno centrale Nr. max 2 luci. Il carter permette di avere un'inclinazione della luce verso l'interno dell'armadio in modo tale da non avere un fascio di luce diretto negli occhi.

Vertical LED LIGHT ZAFFIRO for wooden side panel with carter

Inserted LED light in the horizontal shelf/top supplied with a linking cable. Warm 3000K shade, 110 V or 220 V white lights. Connecting to a remote control or a detector or a switch in the room. As far as the initial/terminal side is concerned No. light: 1. For the central wooden side panel No. lights: max 2. Through the carter it is possible to obtain a light tilt towards the inside part of the wardrobe, not to have a direct ray of light in one's eyes.

Area illuminata _ Lighted area

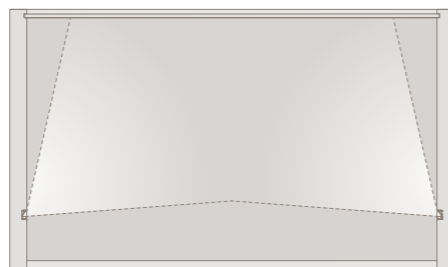

LUCE LED ZAFFIRO VERTICALE PER SPALLE TELAIO _ *VERTICAL LED LIGHT ZAFFIRO FOR SIDE FRAME*



Luce LED ZAFFIRO verticale per spalla telaio centrale con vetro

Luce LED verticale incassata nel telaio, completo di cablaggio per collegamento. Lampade a gradazione calda 3000° K, a luce bianca 110 V o 220 V. Collegabili a dispositivo radio-comando o sensore o interruttore della stanza. È possibile inserire fino a Nr. 2 max luci. Il LED è incassato sul retro del telaio in modo tale da non avere un fascio di luce diretto negli occhi.

Vertical LED LIGHT ZAFFIRO for central side frame with glass

Inserted LED light in the horizontal shelf/top supplied with a linking cable. Warm 3000K shade, 110 V or 220 V white lights. Connecting to a remote control or a detector or a switch in the room. It is possible to insert up to No. lights: max 2. The LED is inserted on the back of the frame, not to have a direct ray of light in one's eyes.

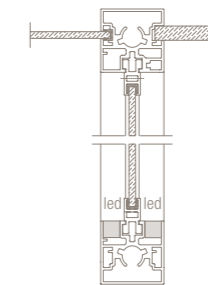

Luce LED ZAFFIRO verticale per spalla telaio centrale senza vetro e iniziale/terminale con vetro e senza vetro

Luce LED verticale incassata nel telaio, completo di cablaggio per collegamento. Lampade a gradazione calda 3000° K, a luce bianca 110 V o 220 V. Collegabili a dispositivo radio-comando o sensore o interruttore della stanza. È possibile inserire fino a Nr. 1 max luce. Il LED è incassato sul retro del telaio in modo tale da non avere un fascio di luce diretto negli occhi.

Vertical LED LIGHT ZAFFIRO for central side frame without glass and initial/terminal with or without glass

Inserted LED light in the horizontal shelf/top supplied with a linking cable. Warm 3000K shade, 110 V or 220 V white lights. Connecting to a remote control or a detector or a switch in the room. It is possible to insert up to No. lights: max 1. The LED is inserted on the back of the frame, not to have a direct ray of light in one's eyes.

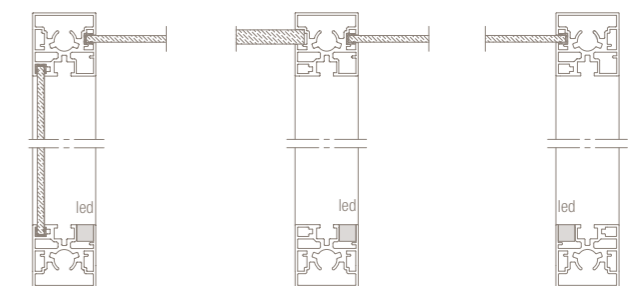

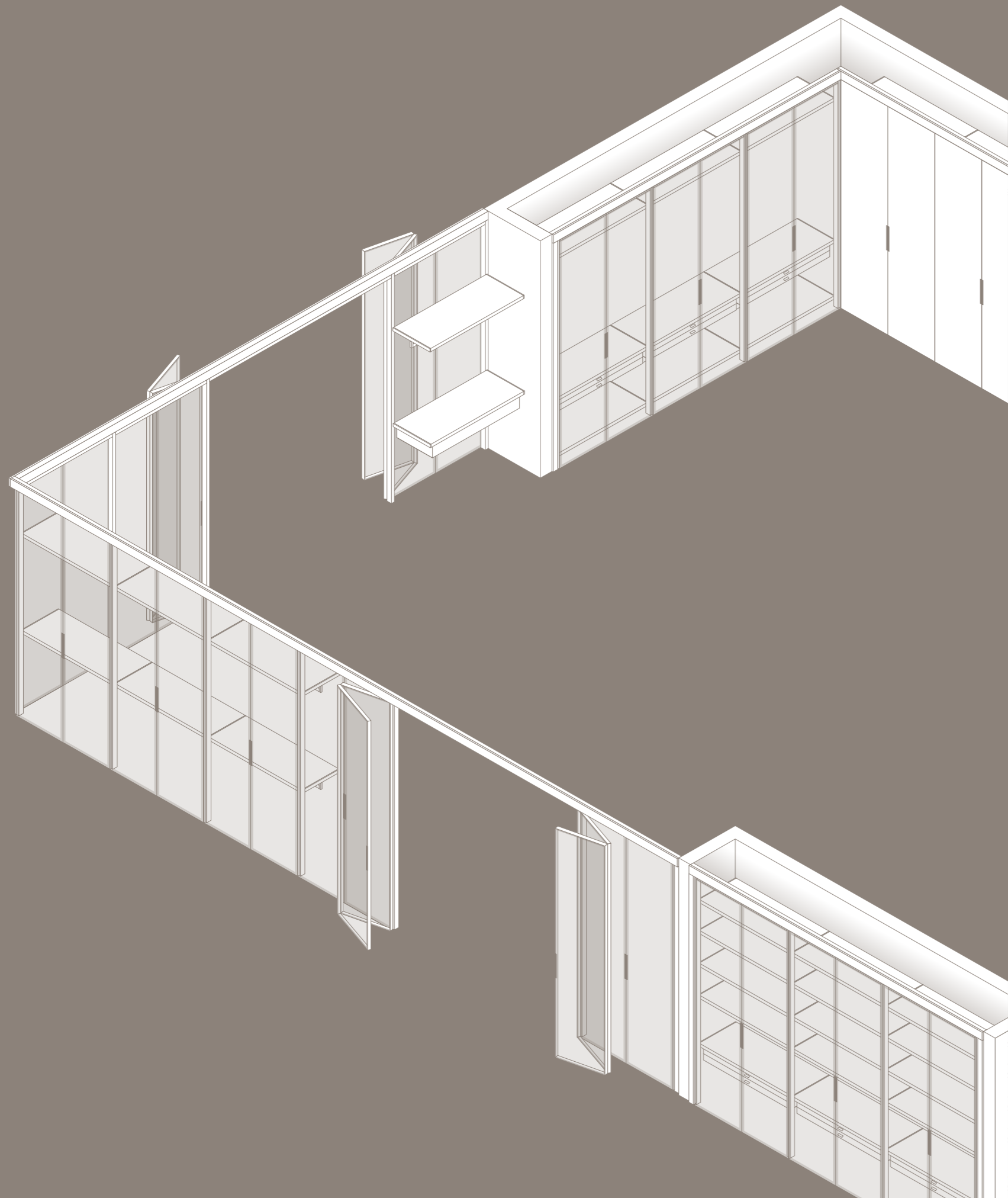

PALO ALTO FREE

IL NUOVO CONCETTO DI CABINA ARMADIO
 THE NEW WALK-IN CLOSET CONCEPT

Evoluzione di Palo Alto I-Box, Palo Alto Free è il nuovo concetto di cabina armadio che prevede l'utilizzo di ante direttamente sorrette da montanti terra-soffitto che ne costituiscono la struttura; questo semplice sistema di chiusura per nicchie o utilizzabile come separatore di spazi supporta una serie di attrezzature per vani, simili a quelle di Palo Alto I-Box.

The evolution of Palo Alto I-Box, Palo Alto Free is the new wardrobe concept that calls for the use of doors directly supported by floor-to-ceiling posts that form the structure. This simple system for closing niches or separating spaces sustains a series of accessories for the compartments, similar to those of the Palo Alto I-Box.

138 Dimensioni e componenti struttura _ *Dimensions and structure components*

148 Finiture struttura _ *Structure finishings*

152 Tipologia aperture _ *Opening typologies*

166 Accessori e dettagli struttura _ *Accessories and structure details*

170 Impianto illuminazione _ *Lighting system*



Nelle pagine precedenti
Sistema notte **Palo Alto Free**, ante **Rex** apertura "RX6"
e ripiani **Frame** in vetro trasparente,
parti in metallo verniciato Canna di Fucile.
Nella pagina a fianco: sistema notte
Palo Alto Free, con ante **Tecno** in nobilitato
Cementino White e maniglie **Gost**.

*On the previous pages:
Palo Alto Free night system, **Rex** doors with "RX6"
opening, doors and **Frame** shelves
in transparent glass, structure in Gunmetal finish.*

*On the side page:
Palo Alto Free night system, **Tecno** doors, melamine
Cementino White, **Gost** handle.*





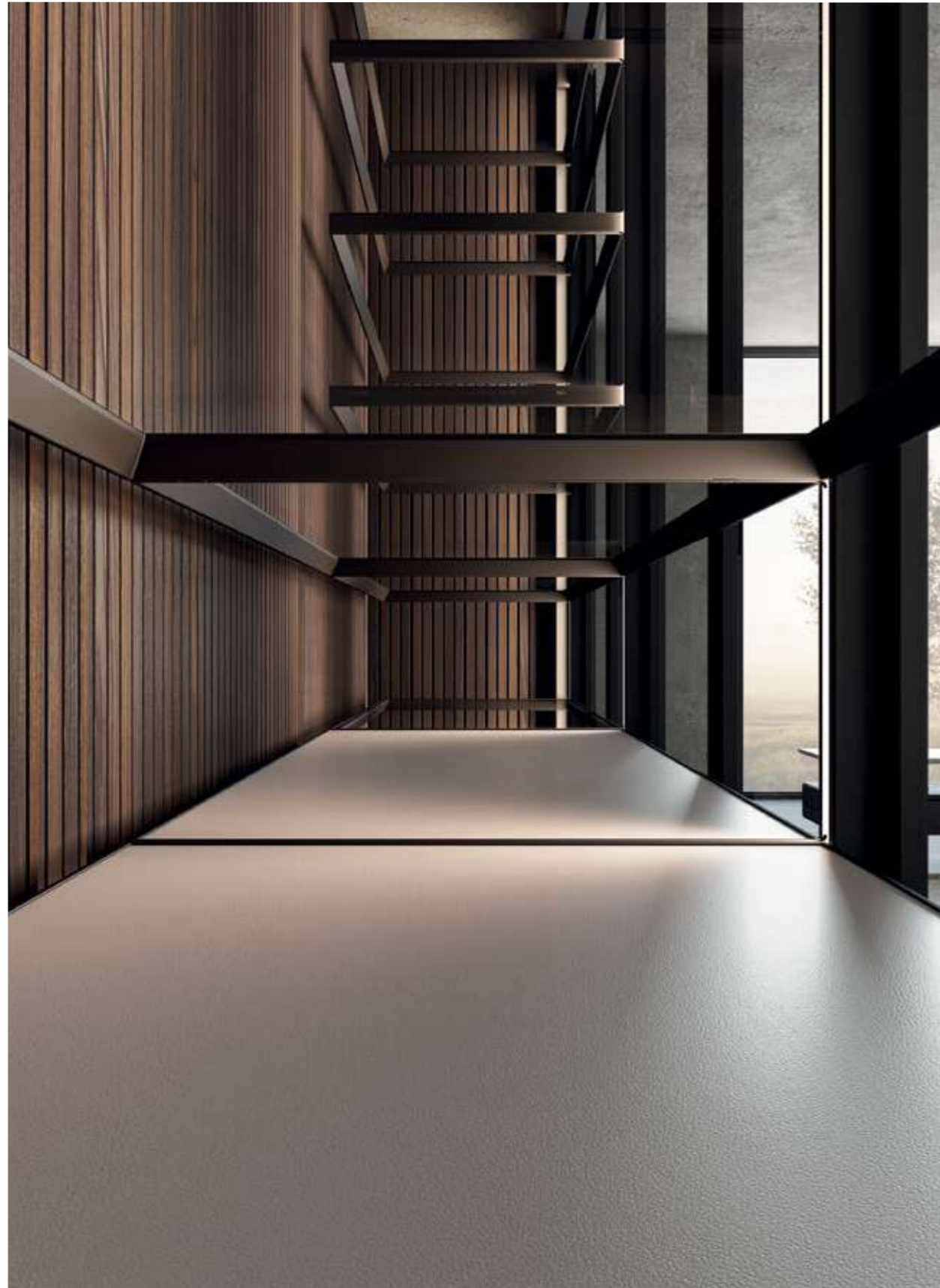

Nelle pagine precedenti e nella pagina a fianco: sistema notte **Palo Alto Free**, con ante **Rex** vetro trasparente, cassettiere sospese nobilitato Shantung di Seta con maniglie Cardea e top in ecopelle, ripiani Frame in vetro trasparente, parti in metallo verniciate Canna di Fucile.

*On the previous pages and on the side page:
Palo Alto Free night system, with transparent glass **Rex** doors, suspended chests of drawers finish in melamine Silk Shantung with Cardea handles and eco-leather top, Framed shelves in transparent glass, metal parts varnished Gunmetal.*

Nella pagina a fianco: dettaglio attrezzatura interna sistema notte **Palo Alto Free**, ripiani Frame in vetro trasparente. Luce Led Zaffiro verticale.

*On the side page: detail of the internal equipment **Palo Alto Free** night system, frame shelves in transparent glass. Vertical Zaffiro LED light.*

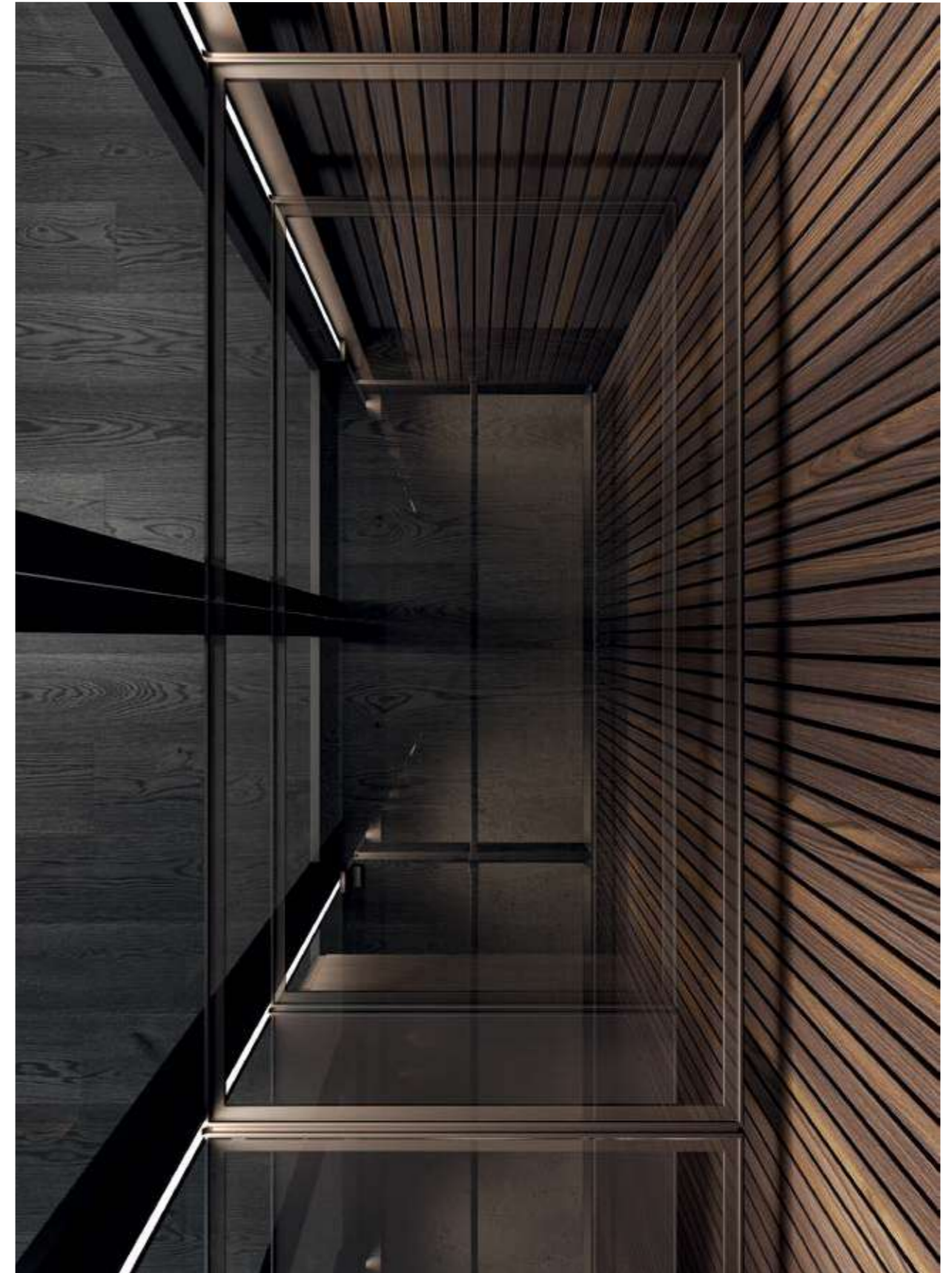

Dimensioni e componenti struttura _ *Dimensions and structure components*



Dimensioni e componenti struttura _ Dimensions and structure components

DIMENSIONI _ DIMENSIONS

Il sistema Palo Alto Free prevede l'installazione da terra a soffitto con 4 modularità in altezza, 1 dimensione in profondità e 8 in larghezza.

Palo Alto Free is designed to be a floor-to-ceiling system that provides 4 height modularities, 1 dimension in depth and 8 in width.

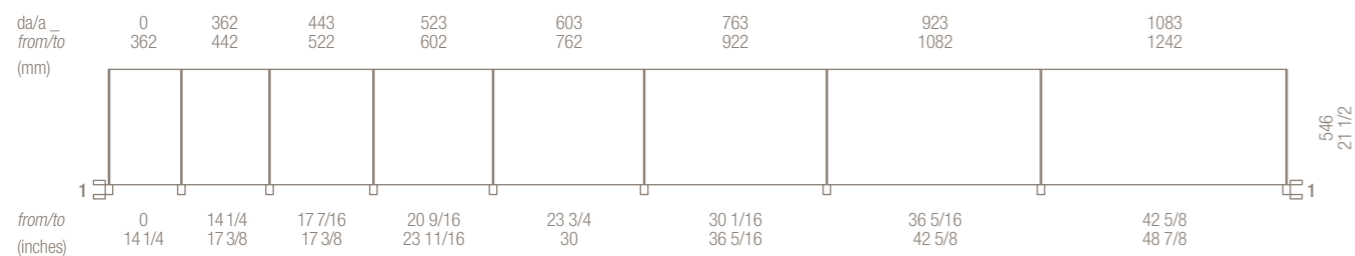
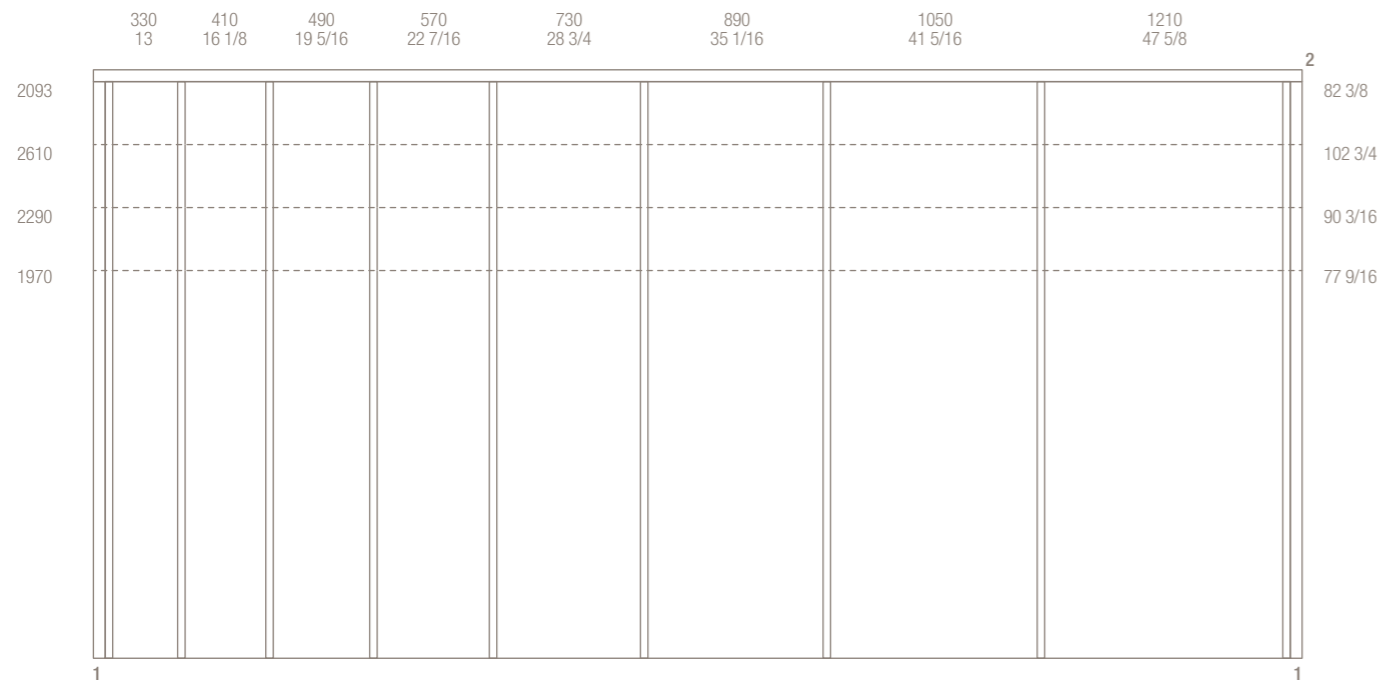

Misure espresse in mm e pollici _ Dimensions are shown in mm and inches

1. Tamponamenti laterali _ side fillers
da/a _ from/to: 60 - 200 mm _ 2 3/8 - 7 7/8"

2. Tamponamento superiore esterno _ Side front filler panel
da/a _ from/to: 51 - 71 mm _ 2 - 2 13/16"

MODULARITÀ _ MODULARITY

Dimensionamento In larghezza: misurare la larghezza del vano alle varie estremità. Larghezza massima, minima e al centro. Per calcolare la larghezza della composizione definire come prima variante la larghezza delle fasce di tamponamento verticali, sommare la larghezza delle fasce tra loro, sottrarre 34 mm e detrarre il risultato totale dalla misura minima del vano.

Dimensionamento In altezza: misurare l'altezza del vano alle varie estremità. Larghezza massima, minima e al centro. Tolleranza massima tra il punto più alto e il punto più basso 20 mm. Per calcolare l'altezza del montante è necessario sottrarre 50 mm dalla misura minima in altezza del vano.

Dimensionamento in profondità: la misura minima in profondità del vano per montare Palo Alto Free inclusa di attrezzature è 654 mm.

Width sizes: measure room width in the various ends. Maximum, minimum and middle width. To calculate the width of the composition, use for the first variant the width of the vertical filler, add the width of the fillers together, deduct 34 mm _ 1 5/16" and subtract the total result from the minimum room niche size.

Height sizes: measure room height in the various ends. Maximum, minimum and middle width. Maximum gap between the highest point and the lowest point 20 mm _ 13/16". To calculate the height of the upright it is necessary to subtract 50 mm from the lowest height of the niche room.

Depth sizing: The minimum depth of the niche to set up Palo Alto Free including equipment is 654 mm _ 25 3/4".

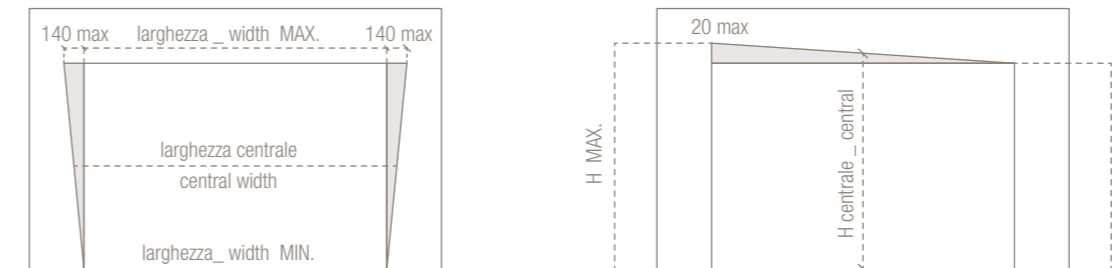

Battente _ Hinged door

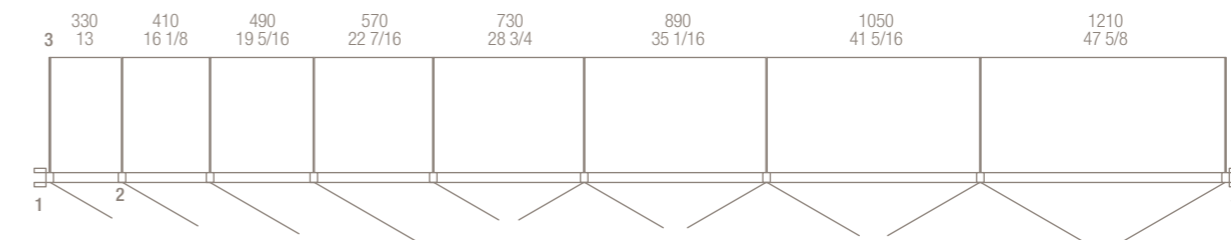

Anta RX6 _ RX6 door



1. Tamponamenti laterali _ side fillers
da/a _ from/to: 60 - 200 mm _ 2 3/8 - 7 7/8"

2. Montanti _ Uprights
38 x 50 mm _ 1 1/2 x 2"

3. Staffe per fissaggio ripiani _ Shelf fixing brackets
6 x 546 mm _ 1/4 x 21 1/2"

Dimensioni e componenti struttura _ Dimensions and structure components

COMPONENTI _ COMPONENTS

1. Montanti _ Uprights
2. Profilo strutturale a soffitto _ Ceiling structural trim
3. Traverso superiore _ Upper crosspiece
4. Staffe _ Brackets
5. Ripiani _ Shelves
6. Ante _ Doors
7. Tamponamento anteriore superiore _ Upper front filler
8. Tamponamenti anteriori laterali _ Front side fillers
9. Tamponamento posteriore superiore _ Upper rear filler
10. Tamponamento posteriore laterale _ Rear side filler

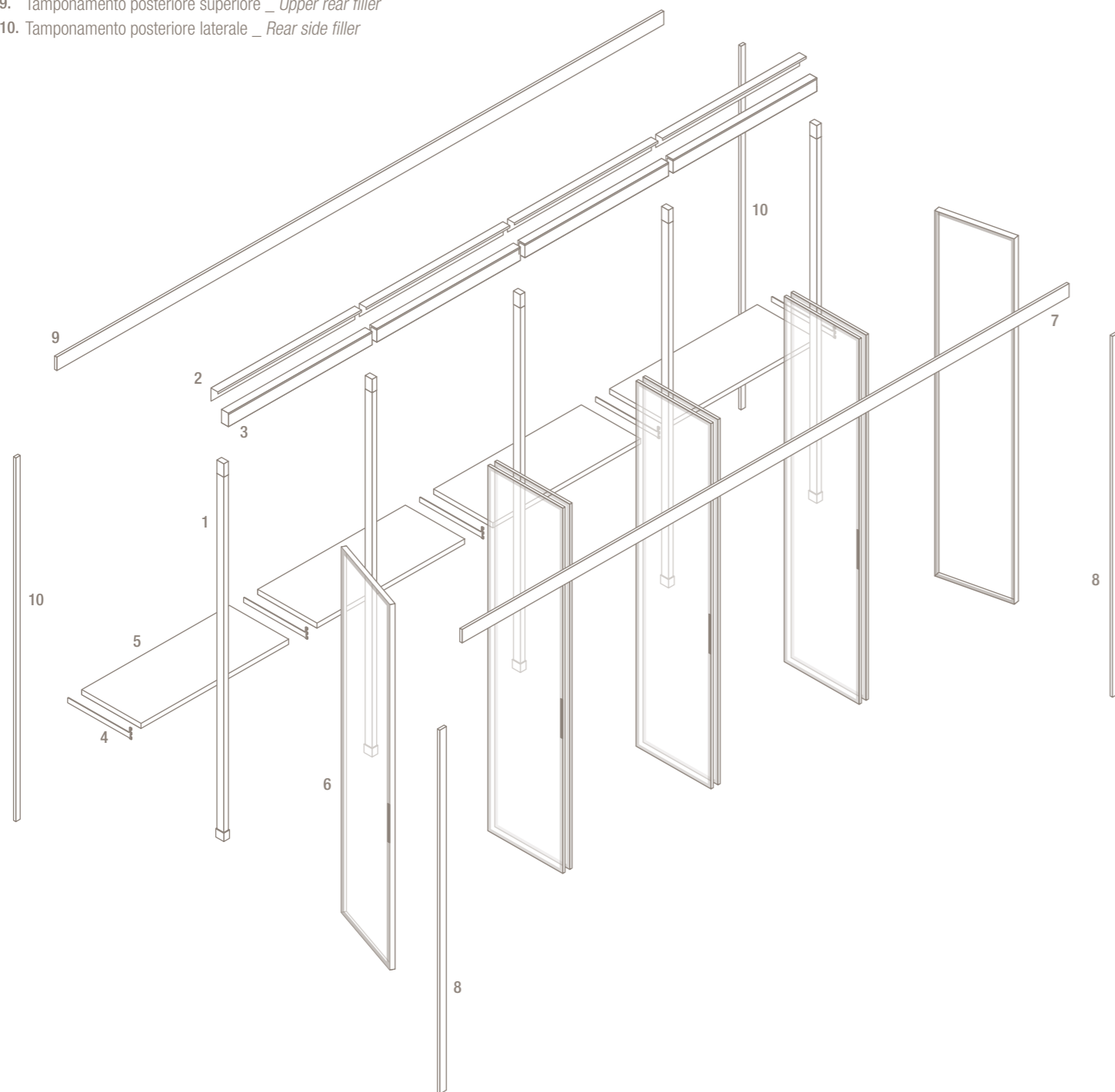

TIPOLOGIE RIPIANI _ SHELVES TYPOLOGIES

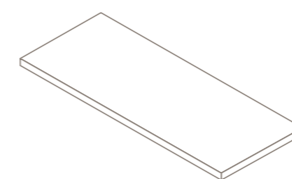

Ripiano Legno

Ripiano in particelle di legno nobilitato o laccato opaco
Sp. 38 mm, P. 546 mm.

Wooden shelf

Chipboard shelf in melamine or matt lacquered Th. 1 1/2", D. 21 1/2".

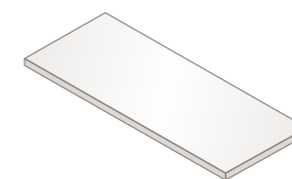

Ripiano Frame

Ripiano in vetro con telaio verniciato metallizzato
Sp. 38 mm, P. 546 mm.

Frame shelf

Glass shelf with varnished metallised frame Th. 1 1/2", D. 21 1/2".

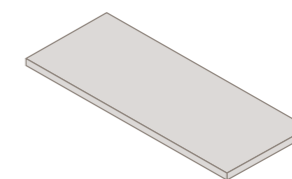

Ripiano Ecopelle

Ripiano in ecopelle con telaio verniciato metallizzato
Sp. 38 mm, P. 546 mm.

Eco-leather Shelf

Eco-leather shelf with varnished metallised frame Th. 1 1/2", D. 21 1/2".

TELAIO _ FRAME



Telaio

Telaio in alluminio verniciato
Sp. 38 mm, P. 50 mm

Frame

Varnished aluminium frame
Th. 1 1/2", D. 2"

STAFFE PER FISSAGGIO RIPIANI _ SHELF FIXING BRACKETS

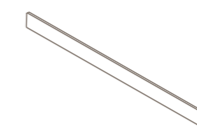

Staffa

Staffa in alluminio verniciato
P. 546 mm, Sp. 6 mm, H 38 mm

Bracket

Varnished aluminum bracket
D. 21 1/2", Th. 1/4", H 1 1/2"

Dimensioni e componenti struttura _ Dimensions and structure components

FOCUS ON TELAIO _ FOCUS ON FRAME

Palo Alto Free è un sistema rivoluzionario che prevede ante e ripiani direttamente sorretti da montanti terra-soffitto, la cui struttura è stata appositamente studiata per sostenere fino a 300 kg di carico per ogni modulo completo costituito da due montanti (SX/DX).

Palo Alto Free is a revolutionary system that calls for the use of doors directly supported by floor-to-ceiling uprights, the structure is specially designed to support up to 300 kg for each complete module consisting of two uprights (Left/Right).

Palo alto Free è un sistema con una struttura che va da pavimento a soffitto. La struttura superiore è composta da un profilo per il fissaggio a soffitto (5), a cui vengono fissati i montanti e i traversi superiori (6) che possono ospitare l'impianto elettrico, il sensore di accensione delle luci led e l'alloggiamento del meccanismo di apertura "RX6" delle ante Rex. Sul traverso superiore sono applicati smove ammortizzanti e calamite di bloccaggio per favorire la chiusura delle ante battenti, in modo silenzioso e armonioso.

Palo alto Free is a floor-to-ceiling system. The upper structure consists of a profile for ceiling mounting (5), to which the upper crosspiece (6) is attached, and can accommodate the electrical system, the sensor for turning on the LED lights, and housing for "RX6" opening mechanism of Rex doors. To ensure a quiet and harmonious closing of the hinged doors shock-absorbing smove and locking magnets are applied to the upper crosspiece.

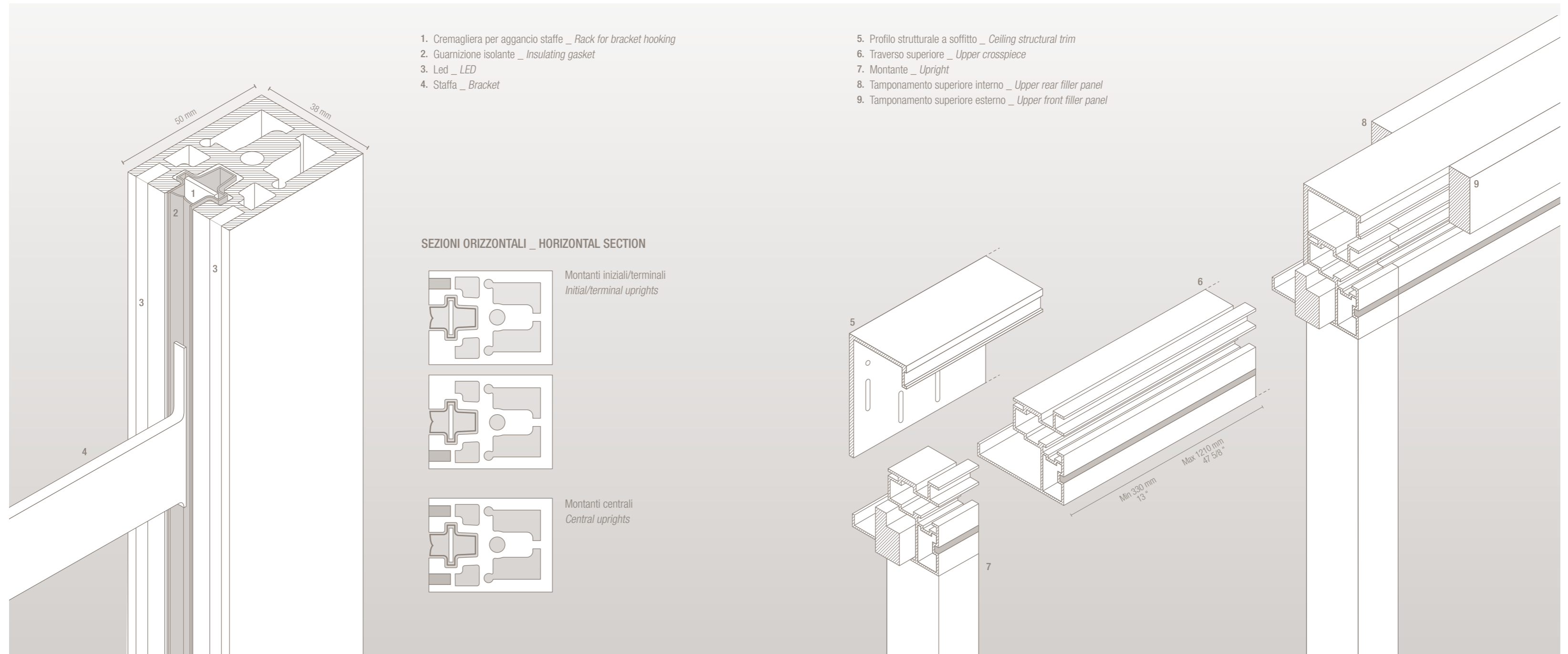

Dimensioni e componenti struttura _ Dimensions and structure components

TAMPONAMENTI _ FILLERS

Palo Alto Free prevede l'uso di fasce di tamponamento superiori e laterali.
I tamponamenti laterali frontali permettono di compensare da un minimo 60 mm fino ad un massimo di 200 mm, i tamponamenti superiori frontali da 51 a 71 mm.

*Palo Alto Free provides for the use of top and side fillers.
Frontal side fillers allow for offsets from a minimum of 60 mm to a maximum of 200 mm, frontal top fillers from 51 to 71 mm.*

SEZIONI ORIZZONTALI _ HORIZONTAL SECTION

Min-Max 38,5 - 178,5 mm 1 9/16 - 7"

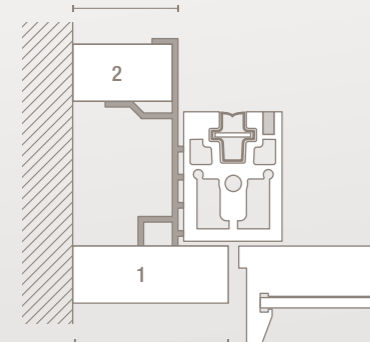

Min-Max 60-200 mm 2 3/8 - 7 7/8"

Tamponamenti laterali _ Side filler panels
Frontale _ Front (1), Posteriore _ Rear (2)

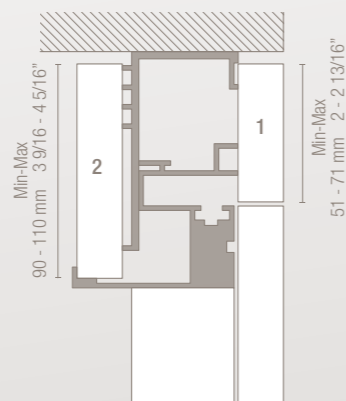

Tamponamenti superiori frontali _ Upper filler panels
Frontale _ Front (1), Posteriore _ Rear (2)

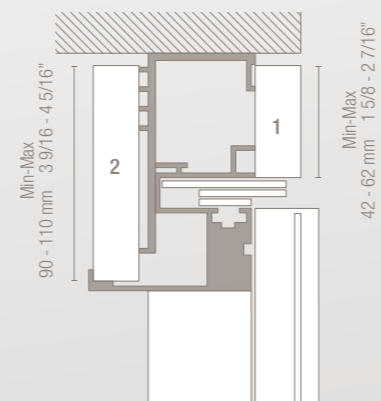

Tamponamenti superiori con apertura anta Rex RX6 _
Upper filler panels with Rex RX6 door opening
Frontale _ Front (1), Posteriore _ Rear (2)

Opzioni tamponamenti con anta Rex / RX6 Rex / RX6 door fillers options

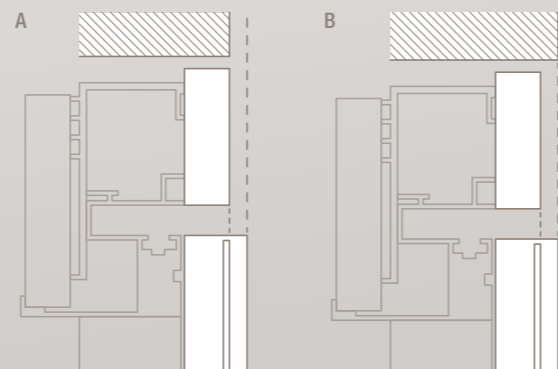

Anta Rex/RX6 con
tamponamento a filo nicchia _
Rex/RX6 with fillers
flush with wall

Anta Rex/RX6 a filo nicchia _
Rex/RX6 door flush with wall

1. Montante _ Upright
2. Tamponamento laterale frontale _
Side frontal filler panel
3. Tamponamento laterale posteriore _
Side rear filler panel
4. Tamponamento superiore frontale _
Upper frontal filler panel
5. Tamponamento superiore posteriore _
Upper rear filler panel
6. Anta _ Door
7. Muro _ Wall

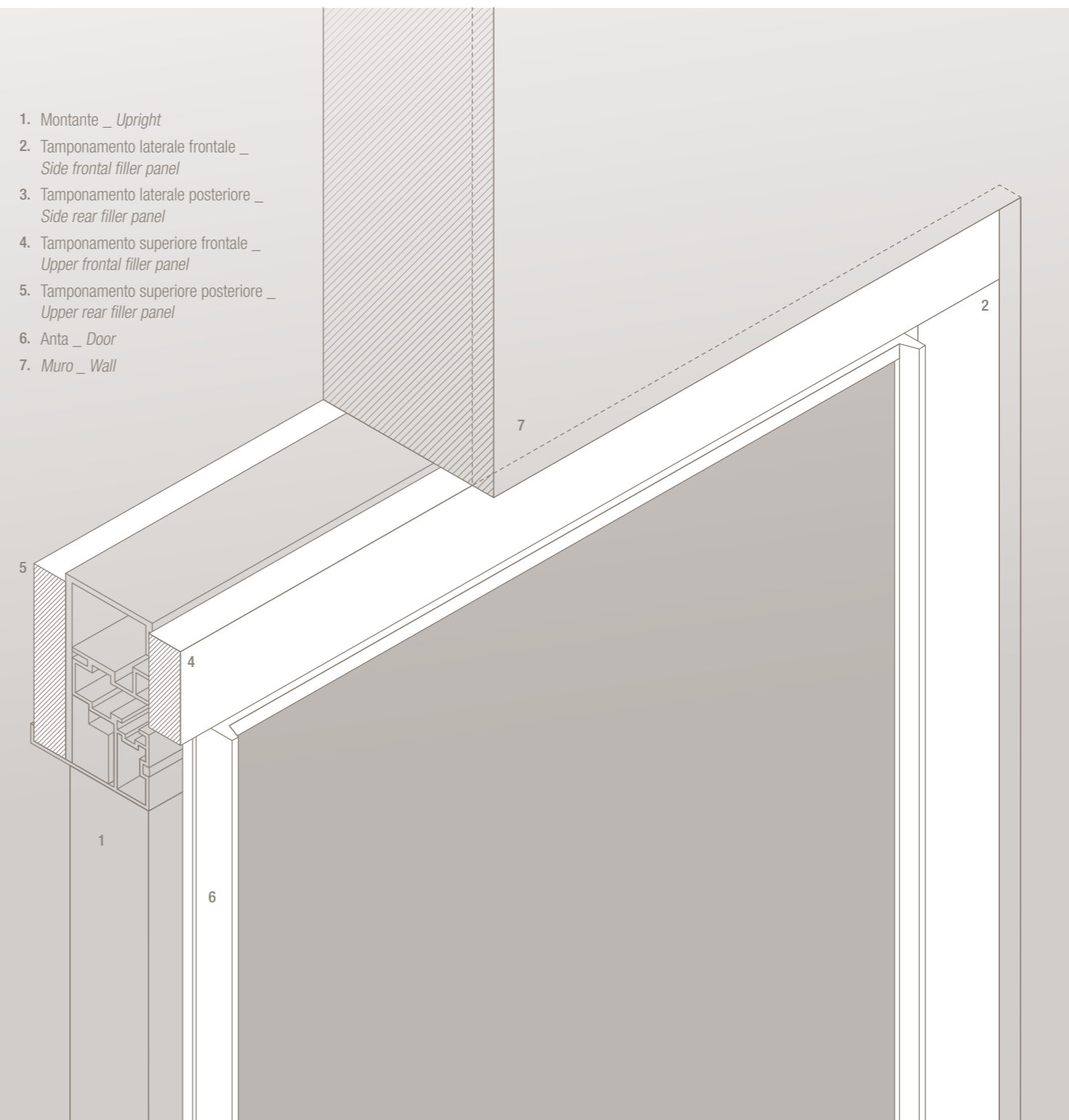

Finiture struttura _ Structure finishings



Finiture struttura _ Structure finishings

TELAIO _ FRAME

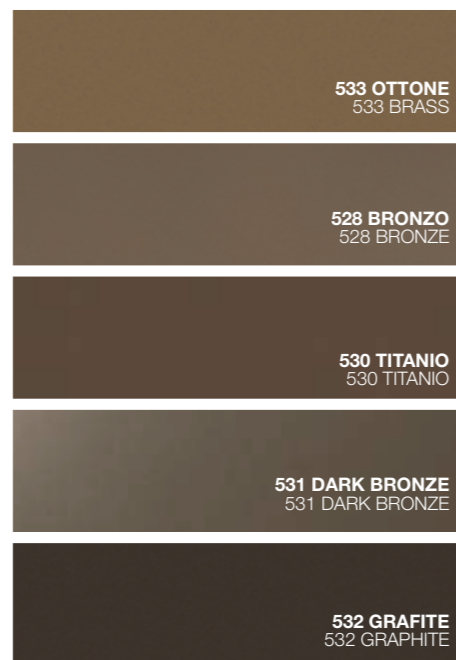
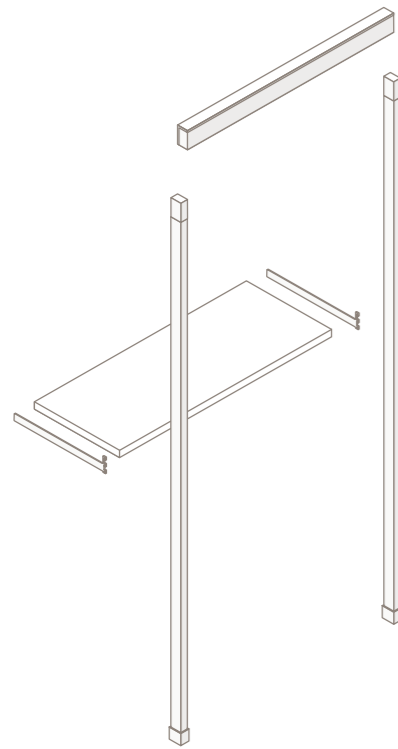

METALLI _ METALS

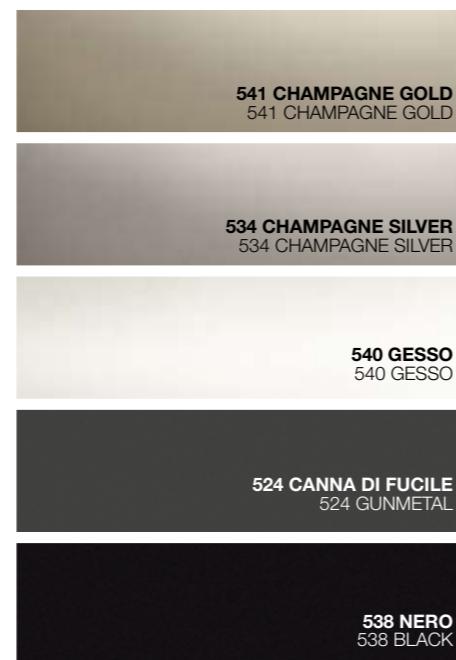

METALLI _ METALS

FASCE DI TAMPONAMENTO _ FILLERS

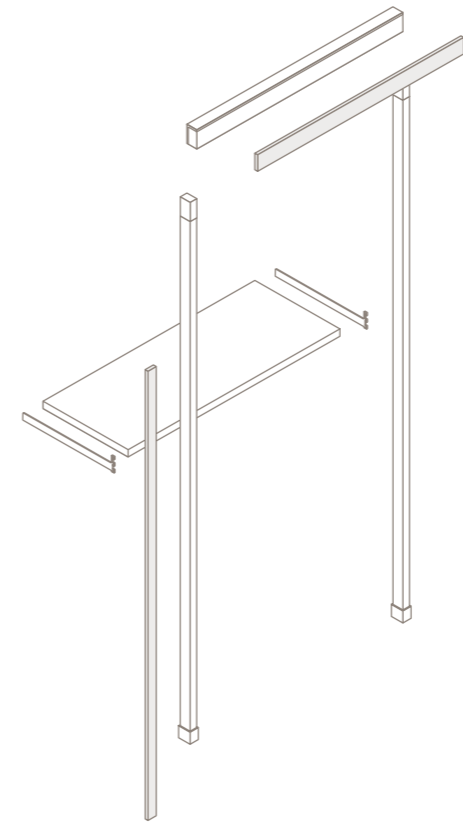

ESSENZE OPACHE _ MATT WOOD



NOBILITATI METALLIZZATI _ METALLIC MELAMINES

Tipologia aperture _ *Opening typologies*





Tipologia aperture _ *Opening typologies*

BATTENTE _ *HINGED DOOR*

La tipologia BATTENTE è la soluzione di apertura standard del sistema Palo Alto Free. Queste soluzioni prevedono 6 dimensioni in altezza, 2 in profondità, 4 in larghezza. Tutte le ante battenti sono fornite con cerniere chiusura SOFT-CLOSING. La maniglia è montata sull'anta destra. È possibile avere come optional la maniglia sull'anta sinistra.

Ante

Tecno, Milano, First, London, Rex.

The HINGED DOOR typology is the standard opening solution of Palo Free system. These solutions provide 6 dimensions (height), 2 (depth) and 8 (width). All hinged doors are supplied with "SOFT-CLOSING" closing hinges. The handle is mounted on the right door. It is possible to optionally have the handle on the left door.

Doors

Tecno, Milano, First, London, Rex.



Tipologia aperture _ *Opening typologies*

BATTENTE _ *HINGED*

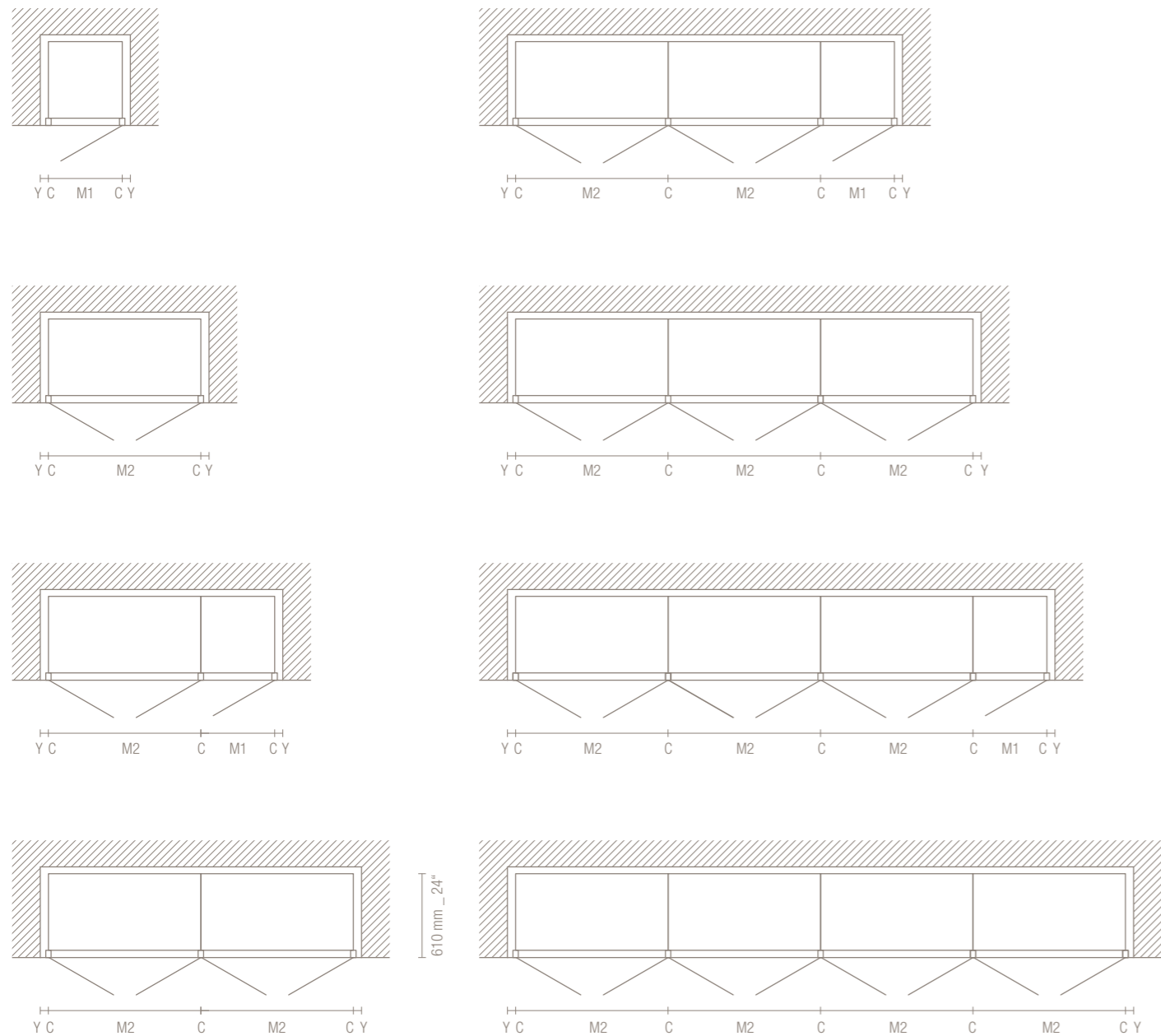

M1. Modulo singolo 362, 442, 522, 602 mm
Single module 14 1/4, 17 3/8, 20 9/16, 23 11/16"

M2. Modulo doppio 762, 922, 1082, 1242 mm
Double module 30, 36 5/16, 42 5/8, 48 7/8"

C. Staffa Sp. 6 mm. per aggancio attrezzatura
Bracket for equipment attachment 1/4" thick

Y. Fascia di tamponamento laterale variabile da minimo 60 mm. a massimo 200 mm.
Lateral filler from a minimum of 2 3/8" to a maximum of 7 7/8".





Tipologia aperture _ *Opening typologies*

BATTENTE/ REX RX6 _ *HINGED/ REX RX6*

La tipologia RX6 è un sottoinsieme di soluzioni dell'anta battente Rex, contraddistinta da un'apertura innovativa con meccanismo, tipo pantografo, che permette di traslare una o più coppie di ante dalla loro posizione di chiusura a quella di totale apertura a 180°, sovrapponendole alle ante del vano adiacente. Si ottengono così aperture totali di vani di due metri circa. Sono possibili INTEGRAZIONI con altre tipologie di ante battenti. Queste soluzioni prevedono 3 dimensioni in altezza, 2 in larghezza. La maniglia Rex è standard per questa tipologia.

Ante
Rex RX6

The RX6 typology is a subset of the hinged Rex door system. Featuring an innovative opening mechanism, similar to a pantograph, that permits the movement of one or more pairs of doors from their closed position to total 180° opening, placed over the doors of the adjacent compartment. The result is the total opening of spaces of about two meters. INTEGRATIONS with other hinged doors are possible. These solutions provide 3 dimensions (height), and 2 (width). Rex handle is standard for this type.

Doors
Rex RX6





Tipologia aperture _ *Opening typologies*

BATTENTE REX RX6 _ *HINGED REX RX6*

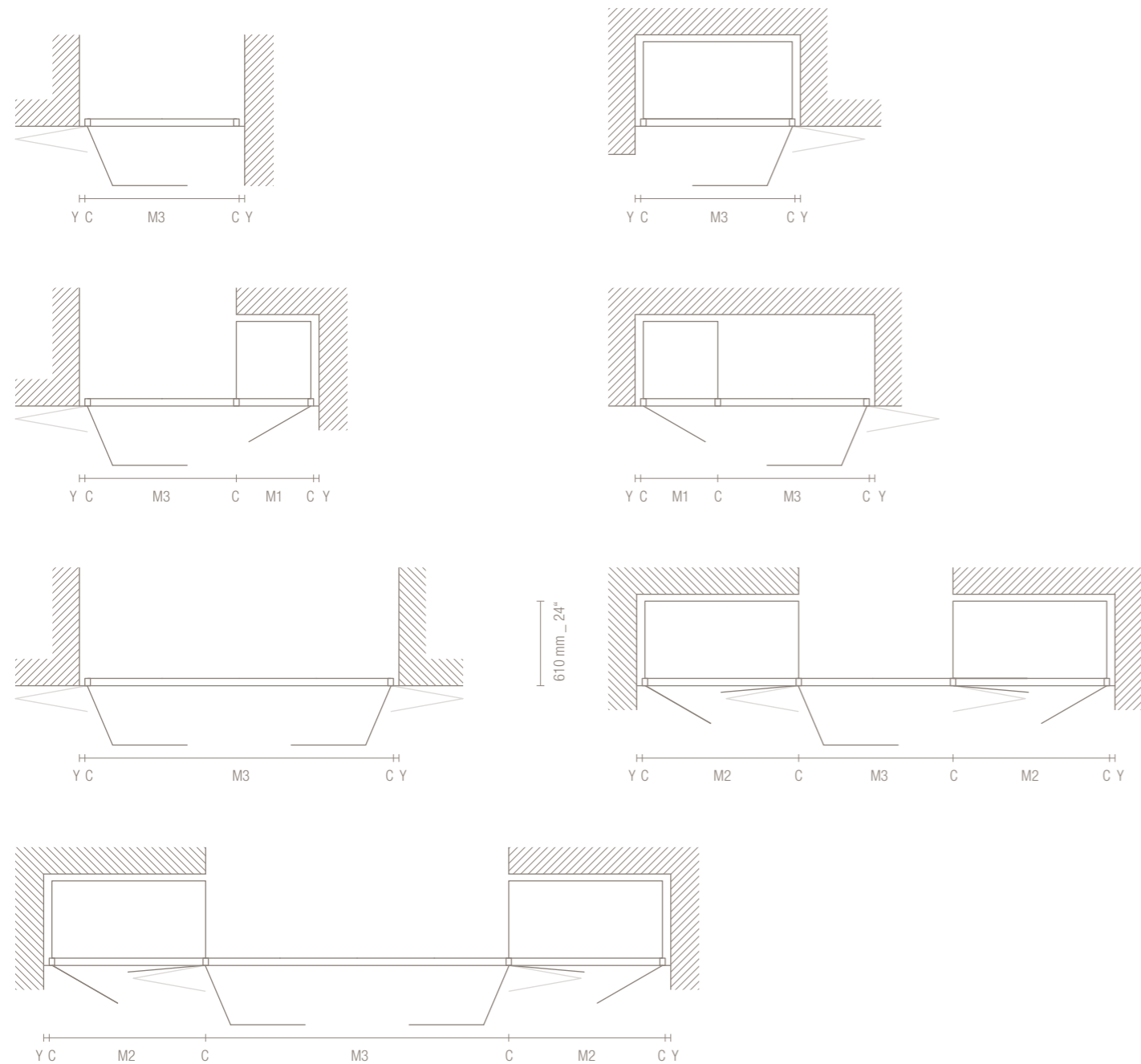

M1. Modulo singolo 362, 442, 522, 602 mm
Single module 14 1/4, 17 3/8, 20 9/16, 23 11/16"

M2. Modulo doppio 762, 922, 1082, 1242 mm
Double module 30, 36 5/16, 42 5/8, 48 7/8"

M3. Modulo per anta Rex apertura RX6 922, 1082 mm
Rex door opening module 36 5/16, 42 5/8"

C. Staffa Sp. 6 mm. per aggancio attrezzatura
Bracket for equipment attachment 1/4" thick

Y. Fascia di tamponamento laterale variabile da minimo 60 mm. a massimo 200 mm.
Lateral filler from a minimum of 2 3/8" to a maximum of 7 7/8".



Accessori e dettagli struttura _ *Accessories and structure details*



Accessori e dettagli struttura _ Accessories and structure details

ACCESSORI STRUTTURALI DI SERIE _ STANDARD STRUCTURE ACCESSORIES



PROFILO ANTI-POLVERE

Montato sul traverso superiore protegge gli interni e garantisce una chiusura ammortizzata delle ante.

ANTI-DUST PROFILE

Mounted on upper crosspiece, it protects inner parts and guarantees doors soft-closing.



GUARNIZIONE A SPAZZOLA

Montata nella parte inferiore delle porte la spazzola protegge gli interni dalla polvere e aiuta la chiusura ammortizzata delle ante.

BRUSH SEAL

Mounted at the doors lower frame, it protects inner parts from dust and helps doors soft-closing.

Accessori e dettagli struttura _ Accessories and structure details

CERNIERE SPALLA TELAIO _ FRAME SIDE HINGE



1. Cerniera in metallo verniciato Canna di Fucile per tutte le ante escluso ante **Narcisse, Zeus e Rex**. Apertura di serie 110°.

*Hinge in Gunmetal varnished for all doors except **Narcisse, Zeus and Rex** doors. Standard opening 110°.*

2. Cerniera **RX6** - Cerniera in metallo verniciato Canna di Fucile esclusiva per anta **Rex RX6**. Apertura di serie a libro 180°.

***RX6** hinge - Hinge in Gunmetal varnished only for **Rex RX6** doors. Standard opening folding doors 180°.*

3. Dettaglio del meccanismo di apertura nella parte superiore dell'anta **Rex RX6**.

*Detail of the opening mechanism at the top of the **Rex RX6** door.*



Accessori e dettagli struttura _ *Accessories and structure details*

RIPIANI _ *SHELVES*

Tramite l'uso di apposite staffe è possibile il fissaggio di mensole e ripiani direttamente sui montanti. Il sistema di aggancio delle staffe avviene su una cremagliera interna nel montante, che grazie a una guarnizione di protezione assicura un risultato completamente invisibile e celato. Il passo dei ripiani è appositamente studiato per seguire al millimetro le stesse altezze degli altri sistemi Palo Alto e permette una perfetta integrazione con i sistemi **I-Box** e **Wall**.

*Through the use of special brackets, it is possible to attach shelves directly to the uprights. The brackets coupling system occurs on an internal rack in the upright, which, thanks to a protective gasket ensures a completely invisible and concealed result. The gap distance of the shelves is specially designed to precisely follow the same heights as other Palo Alto systems allowing perfect integration with **I-Box** and **Wall** systems.*

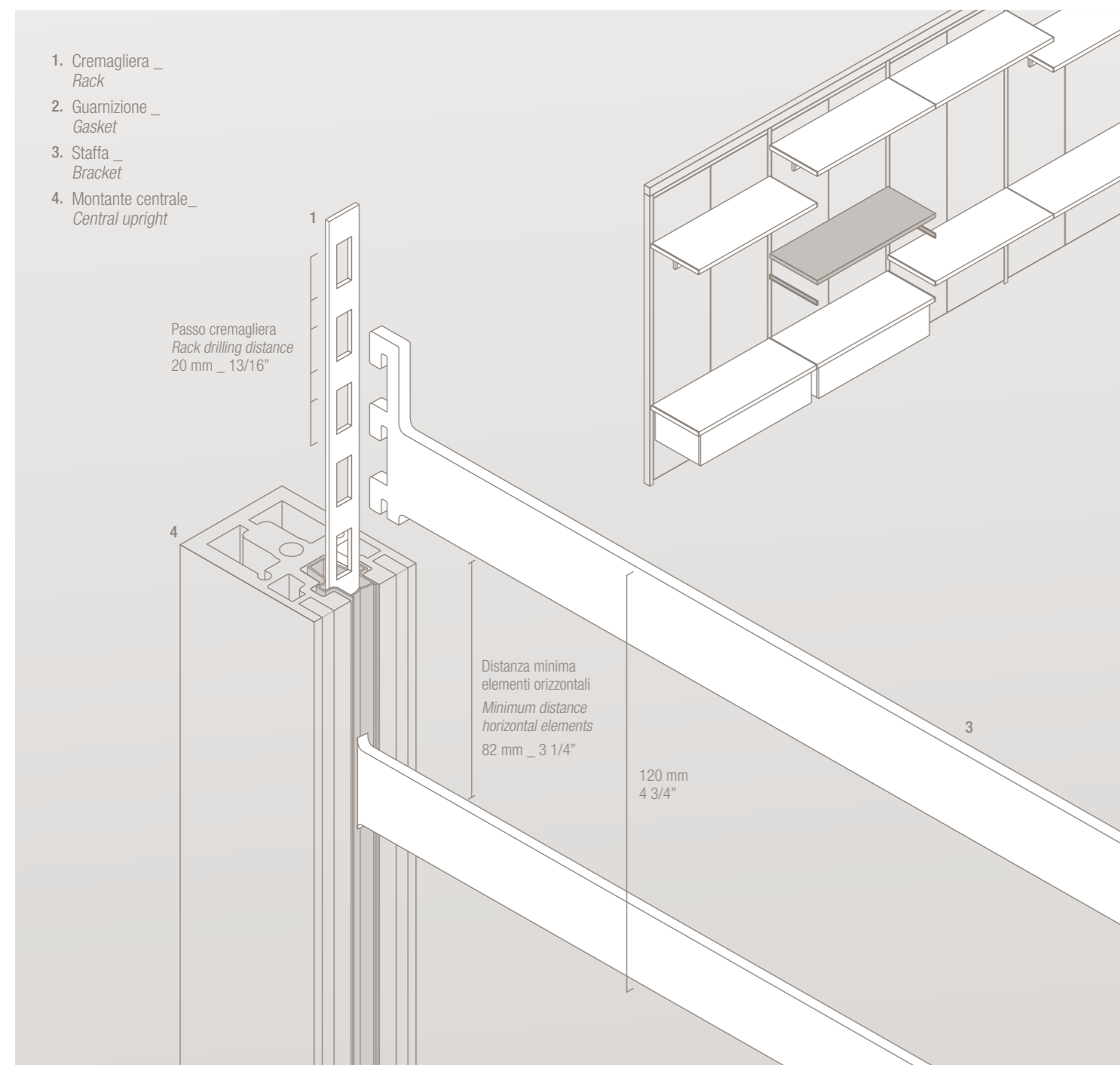

Impianto illuminazione _ *Lighting system*



Impianto illuminazione _ *Lighting system*

LUCE LED ZAFFIRO VERTICALE PER SPALLE LEGNO _ *VERTICAL LED LIGHT FOR WOODEN SIDE PANELS*



1

Luce LED ZAFFIRO verticale _ *Vertical LED LIGHT ZAFFIRO*

1. Per montante iniziale/terminale _ *For start/end upright*

2. Per montante centrale _ *For central upright*

Luce LED verticale incassata nel telaio, completo di cablaggio per collegamento. Lampade a gradazione calda 3000° K, a luce bianca 110 V o 220 V. Collegabili a dispositivo radio-comando o sensore o interruttore della stanza. È possibile inserire fino a Nr. 2 max luci. Il LED è incassato sul retro del telaio in modo tale da non avere un fascio di luce diretto negli occhi.

Inserted LED light in the horizontal shelf/top supplied with a linking cable. Warm 3000K shade, 110 V or 220 V white lights. Connecting to a remote control or a detector or a switch in the room. It is possible to insert up to No. lights: max 2. The LED is inserted on the back of the frame, not to have a direct ray of light in one's eyes.

3. Luce LED ZAFFIRO orizzontale per ripiani frame *Horizontal LED LIGHT ZAFFIRO for wooden shelves*

Luce LED incassata nel ripiano orizzontale, completo di cablaggio per collegamento. Lampade a gradazione calda 3000° K, a luce bianca 110 V o 220 V. Collegabili a dispositivo radio-comando, sensore oppure interruttore della stanza. Disponibili anche per ripiani di elementi terminali ad angolo. Non è possibile inserire le lampade LED orizzontali per ripiani in presenza di schienali vetro.

Inserted LED light in the horizontal shelf/top supplied with a linking cable. Warm 3000K shade, 110 V or 220 V white lights. Connecting to a remote control or a detector or a switch in the room. Also available for the shelves of corner terminal elements. It is not possible to insert horizontal LED lights for shelves with glass back panels.



2



3



4

4. Sensore di movimento temporizzato _ *Time moving detector*

È possibile dotare il sistema di un sensore di movimento temporizzato, che attiva l'impianto di illuminazione all'apertura dell'anta.

It is possible to supply the system with a time moving detector activating the time-release lighting plant when the door is open.

5. Kit Radio-Comando _ *Remote-Control Kit*

È possibile controllare l'impianto di illuminazione tramite un kit Radio-comando oppure allacciare l'impianto direttamente all'interruttore della stanza, senza quindi l'ausilio di un radio-comando o di sensori di movimento.

It is possible to control the lighting system through a remote controller, it is also possible to directly connect the lighting plant to the switch in the room; therefore, without any remote control or moving detectors.



5

Focus On

PASSAGGIO CAVI _ WIRE PASSAGE

Impianto elettrico verticale _ Vertical light system

L'impianto elettrico verticale è composto da led (con luce continua oppure puntiforme) alloggiato all'interno dei montanti iniziali, terminali e centrali.

L'impianto elettrico può essere gestito da sensori, telecomando o presa comandata.

The vertical electrical system is composed by one LED with continuous or punctiform light placed inside the start, central or end upright. The electrical system can work through sensors, remote control or wall sockets.

Impianto elettrico orizzontale _ Horizontal light system

L'impianto elettrico orizzontale è composto dai led (luce continua) presenti sugli accessori interni, l'elettificazione viene trasmessa grazie all'innovativo sistema a cremagliera elettrificata (patent pending) che permette di montare e spostare ripiani o accessori con illuminazione integrata in totale sicurezza, senza cavi o connessioni visibili.

Horizontal light system is composed by LEDs with continuous light applied on internal accessories; electrification is transmitted through the innovative electrified rack system (patent pending), which allows shelves or accessories with integrated lighting to be mounted and moved safely, without visible cables or connections.

Cremagliera elettrificata _ Electrified rack

Il sistema prevede l'inserimento nel montante in alluminio di una cremagliera in acciaio al carbonio (fig. 2), elettrificata a bassissima tensione (12-24V) e isolata tramite un estruso plastico in policarbonato ignifugo V0 UL-94 (fig. 3). Per garantire la migliore conduzione elettrica, la cremagliera in acciaio è preventivamente sottoposta a uno speciale trattamento superficiale di ramatura e nichelatura.

The system involves the insertion of a carbon steel rack (fig. 2) electrified at very low voltage (12-24V) into the aluminum upright, the rack is insulated by means of a V0 UL-94 fireproof polycarbonate plastic extrusion (fig.3). To ensure the best electrical conduction, the steel rack is previously subjected to a special surface treatment of copper and nickel plating.

Staffe con predisposizione per elettrificazione _ Brackets with electrical set-up

Le staffe di supporto (fig. 4) che trasmettono la corrente ai ripiani sono preventivamente sottoposte a uno speciale trattamento superficiale di ramatura e stagnatura che le rende conduttive, vengono poi successivamente ricoperte con vernice epossidica isolante lasciando esposto solo il punto di contatto per l'elettificazione (fig. 5).

Shelves support brackets (fig. 4) with electrical set-up in order to conduct power are first subjected to a special surface treatment of copper and tin plating to make them conductive, they are then successively covered with insulating epoxy paint, leaving only the contact point for electrification exposed (fig. 5).

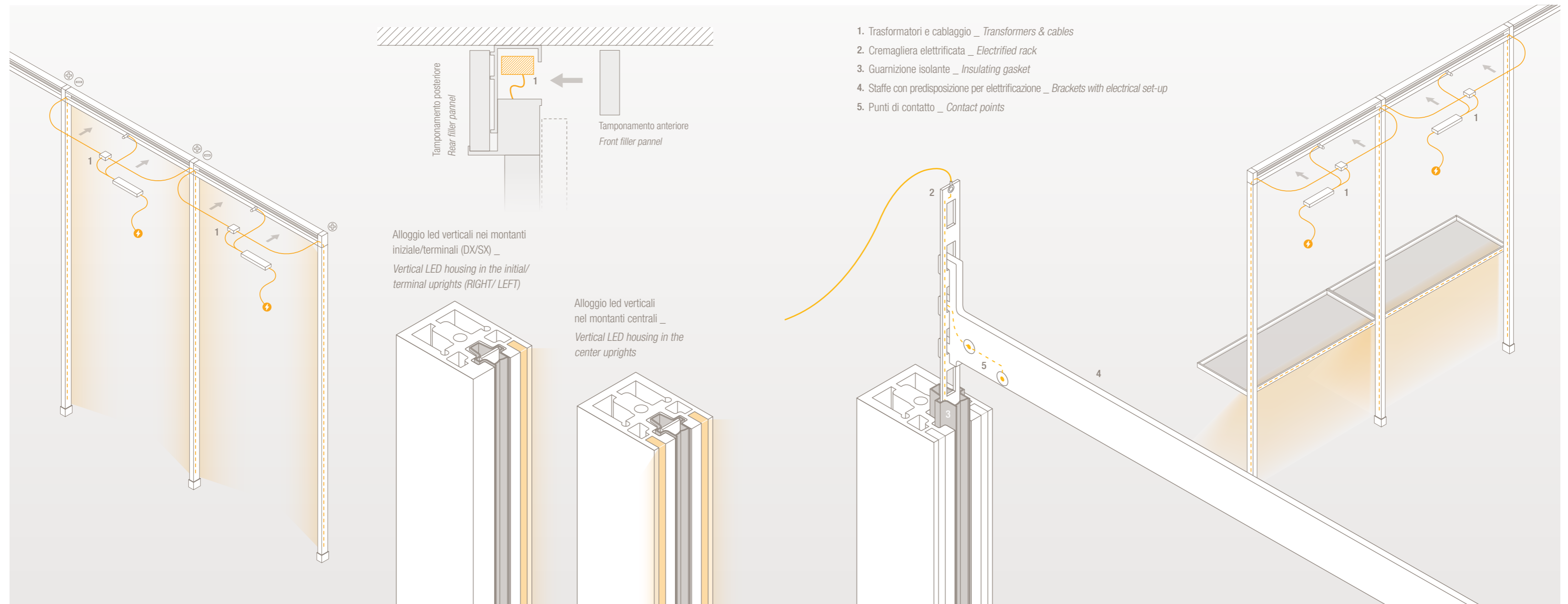

PALO ALTO WALL

SISTEMA NOTTE A BOISERIE ATTREZZABILE
EQUIPPABLE BOISERIE NIGHT SYSTEM

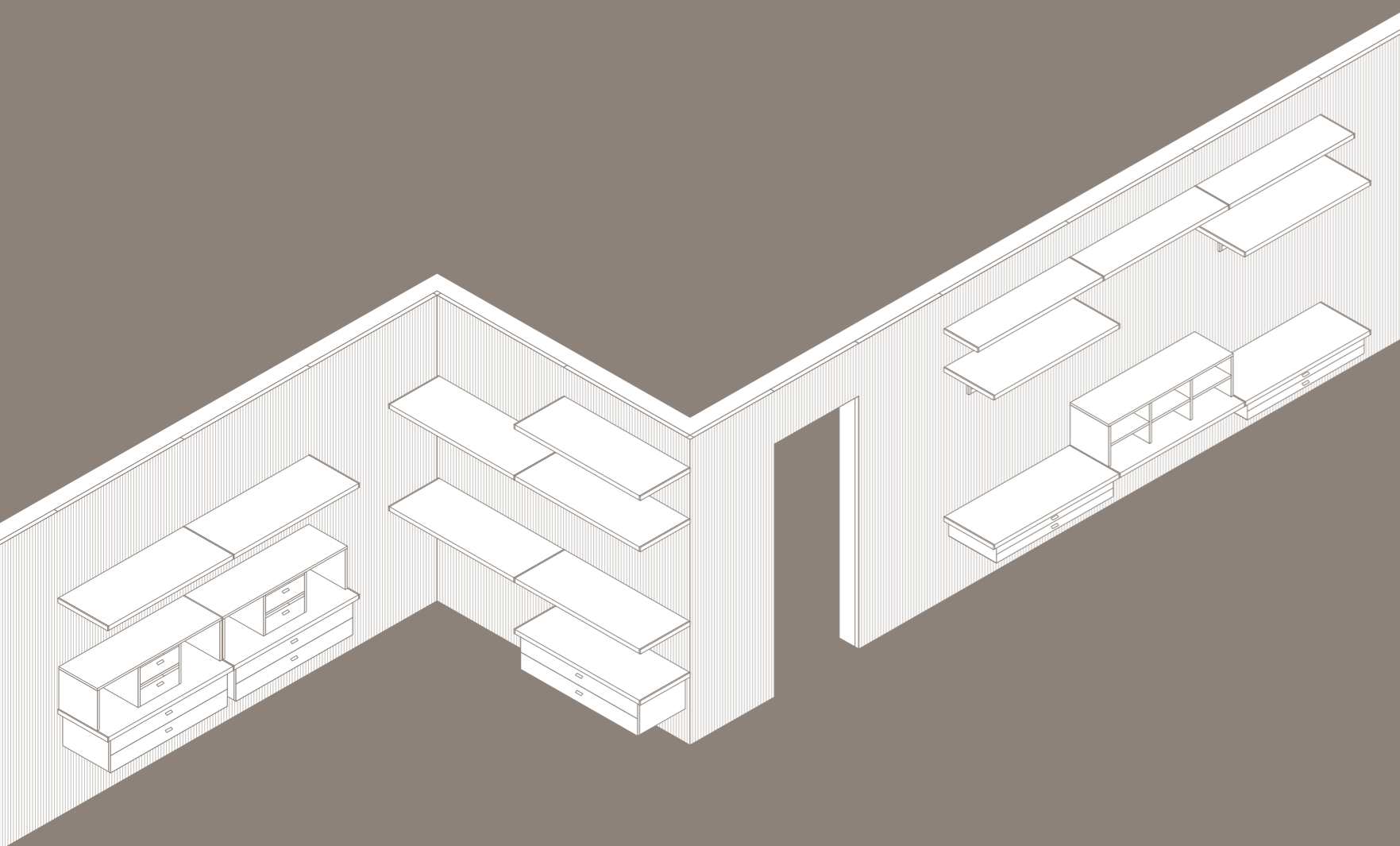

Palo Alto Wall rappresenta l'elemento distintivo di una zona notte esclusiva, funzionale e sofisticata, con l'eleganza dello stile inconfondibile MisuraEmme espresso in ogni dettaglio, anche costruttivo, supera il limite dell'essere un semplice prodotto a cremagliera e diventa un rivestimento murale terra soffitto, con la possibilità di integrare tutta l'attrezzatura dedicata alla zona notte, già compatibile con i sistemi Palo Alto Free e Palo Alto I-Box.

Palo Alto Wall represents the distinctive element of an exclusive, functional and sophisticated night area, with the elegance of the unmistakable MisuraEmme style expressed in every detail, including construction, it goes beyond the limit of being a simple rack product and becomes a wall covering floor to ceiling, with the possibility of integrating all the equipment dedicated to the night area, already compatible with the Palo Alto Free and Palo Alto I-Box systems.

196 Dimensioni e componenti struttura _ *Dimensions and structure components*

206 Finiture struttura _ *Structure finishings*

210 Accessori e dettagli struttura _ *Accessories and structure details*

214 Impianto illuminazione _ *Lighting system*





Nelle pagine precedenti: sistema notte **Palo Alto Wall**, con pannelli in essenza Millerighe Tabacco, cassettiere sospese in ecopelle con top in essenza Tabacco, maniglie Cardea, ripiani Frame in vetro trasparente, parti in metallo verniciato Canna di Fucile.

Nella pagina a fianco: sistema notte **Palo Alto Wall**, con pannelli in finitura Paglia Intrecciata, cassettiere sospese essenza Tabacco, maniglie Cardea in ecopelle lavorata, ripiani Frame in vetro trasparente, parti in metallo verniciate Canna di Fucile.

*On the previous pages: **Palo Alto Wall** night system in Tobacco veneer Millerighe finish, with hanging chest of drawers units, top in Tobacco essence, eco-leather fronts and Cardea handles, transparent glass Frame shelves with Gunmetal varnished frame.*

*On the side page: **Palo Alto Wall** night system, with panel in Woven Straw finish, suspended chests of drawers finish in Tobacco veneer with embossed eco-leather Cardea handles, Framed shelves in transparent glass, metal parts varnished Gunmetal.*



Nella pagina a fianco: dettaglio del sistema notte **Palo Alto Wall**, con pannelli in finitura Paglia Intrecciata, cassettiere sospese essenza Tabacco, maniglie Cardea in ecopelle lavorata, ripiani Frame in vetro trasparente, parti in metallo verniciate Canna di Fucile.

*On the side page: **Palo Alto Wall** night system detail, with panel in Woven Straw finish, suspended chests of drawers finish in Tobacco veneer with embossed eco-leather Cardea handles, Framed shelves in transparent glass, metal parts varnished Gunmetal.*

Nella pagina a fianco: dettaglio finitura Paglia Intrecciata
su sistema notte **Palo Alto Wall** con parti
in metallo verniciate Canna di Fucile
e appendiabiti rivestito in ecopelle lavorata.

*On the side page: Woven Straw finish
close up on **Palo Alto Wall** night system,
metal parts painted Gunmetal, hanging rail
upholstered in embossed eco-leather.*





 Nella pagina a fianco: dettaglio della cassettera sospesa con top in ecopelle e della pannellatura in Paglia Intrecciata del sistema notte **Palo Alto Wall** con parti in metallo verniciate Canna di Fucile e appendiabiti rivestito in ecopelle lavorata.

*On the side page: detail of the suspended chest of drawers with eco-leather top and Woven Straw paneling of the **Palo Alto Wall** night system with Gunmetal varnished metal parts and hanging rail upholstered in embossed eco-leather.*



Nelle pagine precedenti e nella pagina a fianco:
 sistema notte **Palo Alto Wall**, schienali nobilitato
 Shantung di Seta. Elemento sospeso svuotatasche
 e portapantaloni in nobilitato Tabacco. Elemento dedicato
 sistema portacamicie in nobilitato Tabacco, cassettini
 opzionali in ecopelle lavorata, maniglie Cardea
 in ecopelle lavorata.

Cassettiera sospesa in nobilitato Tabacco,
 top in ecopelle lavorata, maniglie Cardea in ecopelle
 lavorata. Ripiani frame in metallo verniciato
 Canna di Fucile e vetro trasparente Fumè.
 Tubi appendiabiti rivestiti in ecopelle lavorata.

*On the previous pages and on the side page:
Palo Alto Wall night system, back in Silk Shantung
 melamine. Suspended pocket emptier and trouser rack
 in Tobacco melamine. Dedicated system element for
 shirt holders in Tobacco melamine, optional drawers
 in embossed eco-leather, Cardea handles in embossed
 eco-leather. Suspended chest of drawers in Tobacco
 melamine, top in embossed eco-leather, Cardea handles
 in embossed eco-leather. Frame shelves in Gunmetal
 painted metal and Fumè transparent glass. Hanging rail
 upholstered in embossed eco-leather.*

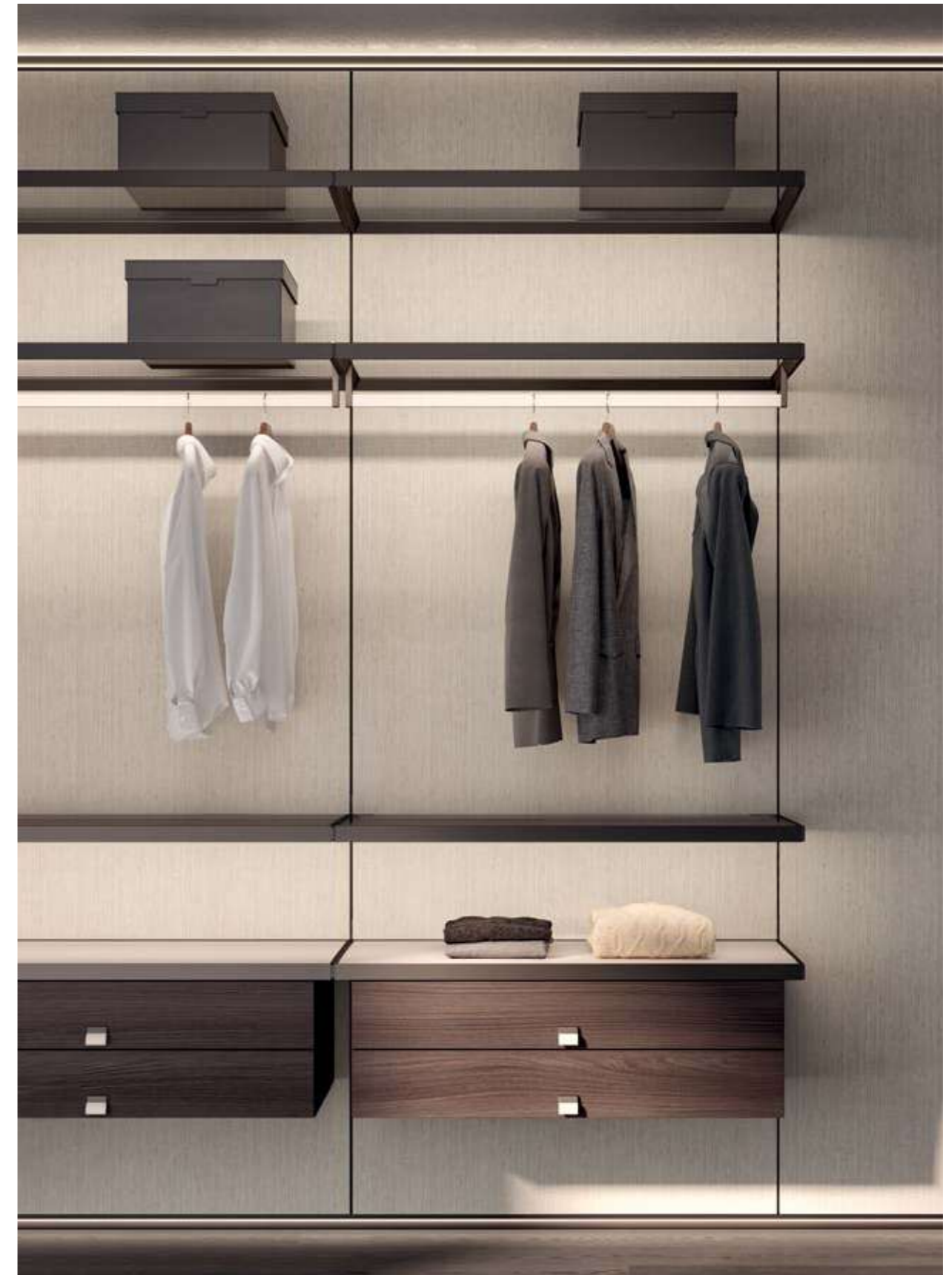



Nelle pagine precedenti e nella pagina a fianco:
 Sistema notte **Palo Alto Wall**, schienale in Essenza
 Millerighe Tabacco, cassettiere sospese nobilitato
 Shantung di Seta con maniglie Cardea e top ecopelle
 lavorata, ripiani Frame in vetro Fumè trasparente,
 tubi appendiabiti in ecopelle lavorata
 e parti metallo verniciate Canna di Fucile.

*On the previous pages and on the side page:
Palo Alto Wall night system, with back in Millerighe
 Tobacco veneer, suspended chests of drawers finish
 in melamine Silk Shantung with embossed
 eco-leather top and Cardea handles, Frame shelves
 in Fumè transparent glass, hanging rail upholstered in
 embossed eco-leather, metal parts painted Gunmetal.*

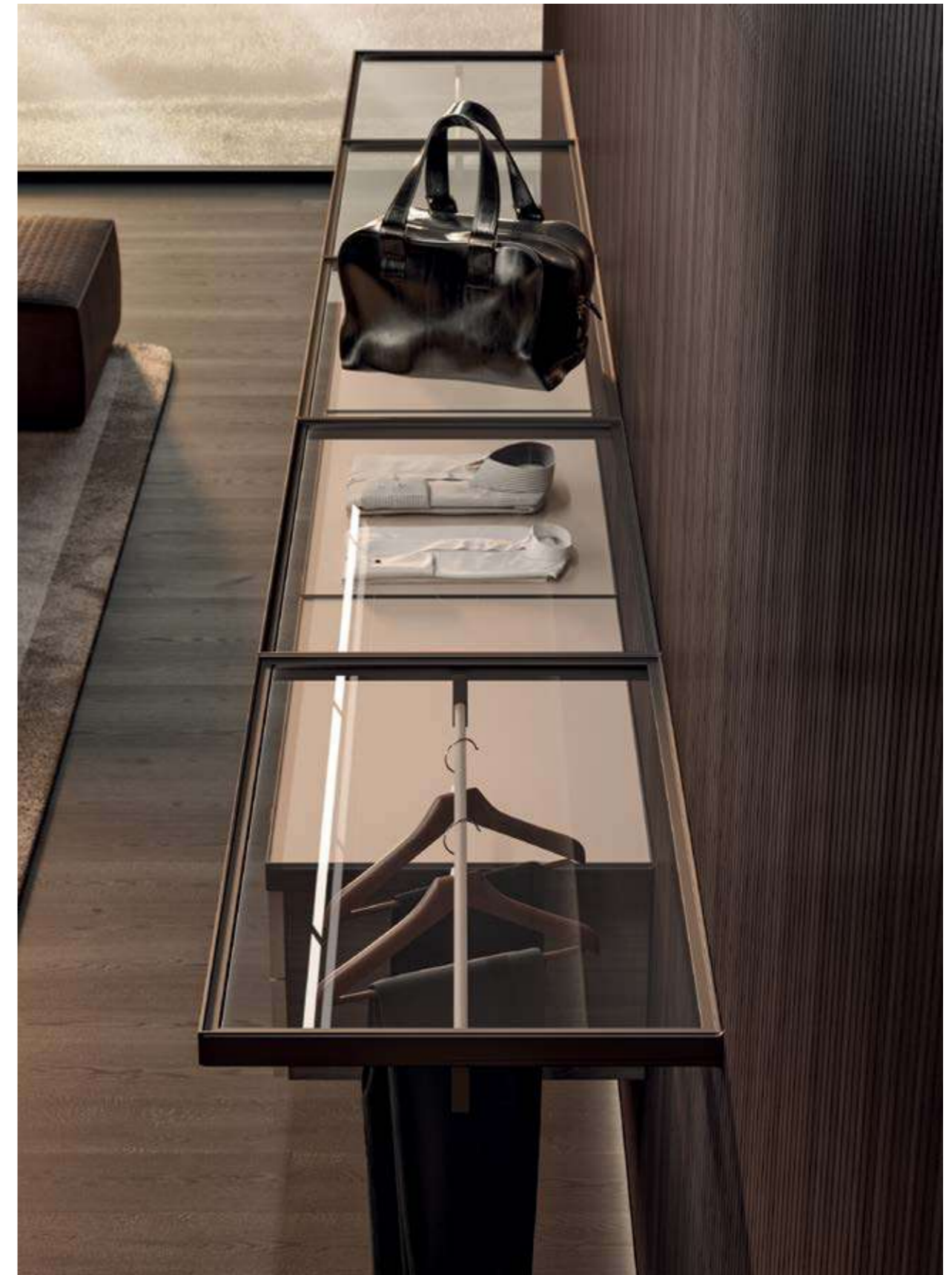

Dimensioni e componenti struttura _ *Dimensions and structure components*



Dimensioni e componenti struttura _ Dimensions and structure components

DIMENSIONI _ DIMENSIONS

Il sistema Wall prevede 6 dimensioni in altezza, 2 in profondità e 8 in larghezza. Per definire la larghezza della composizione vanno sommati, alle larghezze dei moduli, lo spessore delle staffe da 6 mm. Inoltre all'inizio e alla fine della composizione va aggiunta la larghezza del tamponamento prescelto. Larghezza e altezza sono riducibili al millimetro senza supplemento. L'ingombro della boiserie da filo muro al filo anteriore del pannello di rivestimento è di 62 mm. Per calcolare l'ingombro complessivo della boiserie compresa di accessori è necessario aggiungere 2 mm d'aria più la profondità dell'accessorio prescelto.

Palo Alto Wall provides 6 dimensions in height, 2 in depth and 8 in width. To define the width of the composition, the thickness of the 6 mm brackets must be added to the width of the modules. In addition, at the beginning and end should be added to the composition the width of the chosen filler. Width and height can be reduced per millimeter without surcharge. The dimension of the boiserie from the wall to the front edge of the cladding panel is 62 mm. To calculate the overall dimensions of the boiserie including accessories, it is necessary to add 2 mm of space plus the depth of the chosen accessory.

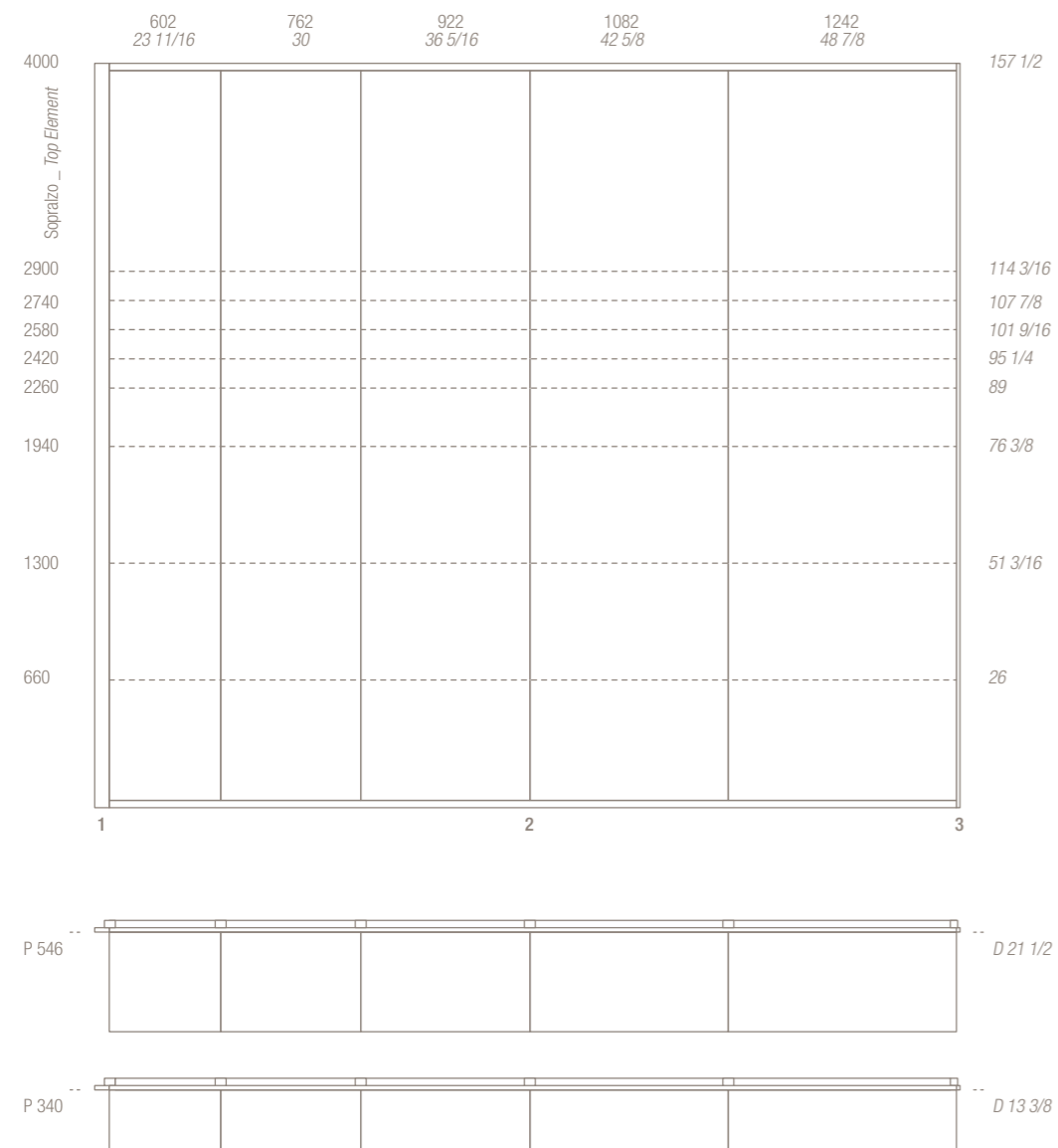

Misure espresse in mm e pollici _
Dimensions are shown in mm and inches

1. 2. 3. Tamponamenti laterali, superiori e inferiori_ side, top and bottom fillers

1. Montanti iniziali/terminali _ Start/End uprights
2. Montanti centrali _ Central uprights
3. Pannelli _ Panels
4. Tamponamento laterale _ Lateral filler
5. Carter orizzontali superiori e inferiori _ Upper and lower horizontal casings
6. Staffe per fissaggio ripiani _ Fixing brackets
7. Ripiani _ Shelves

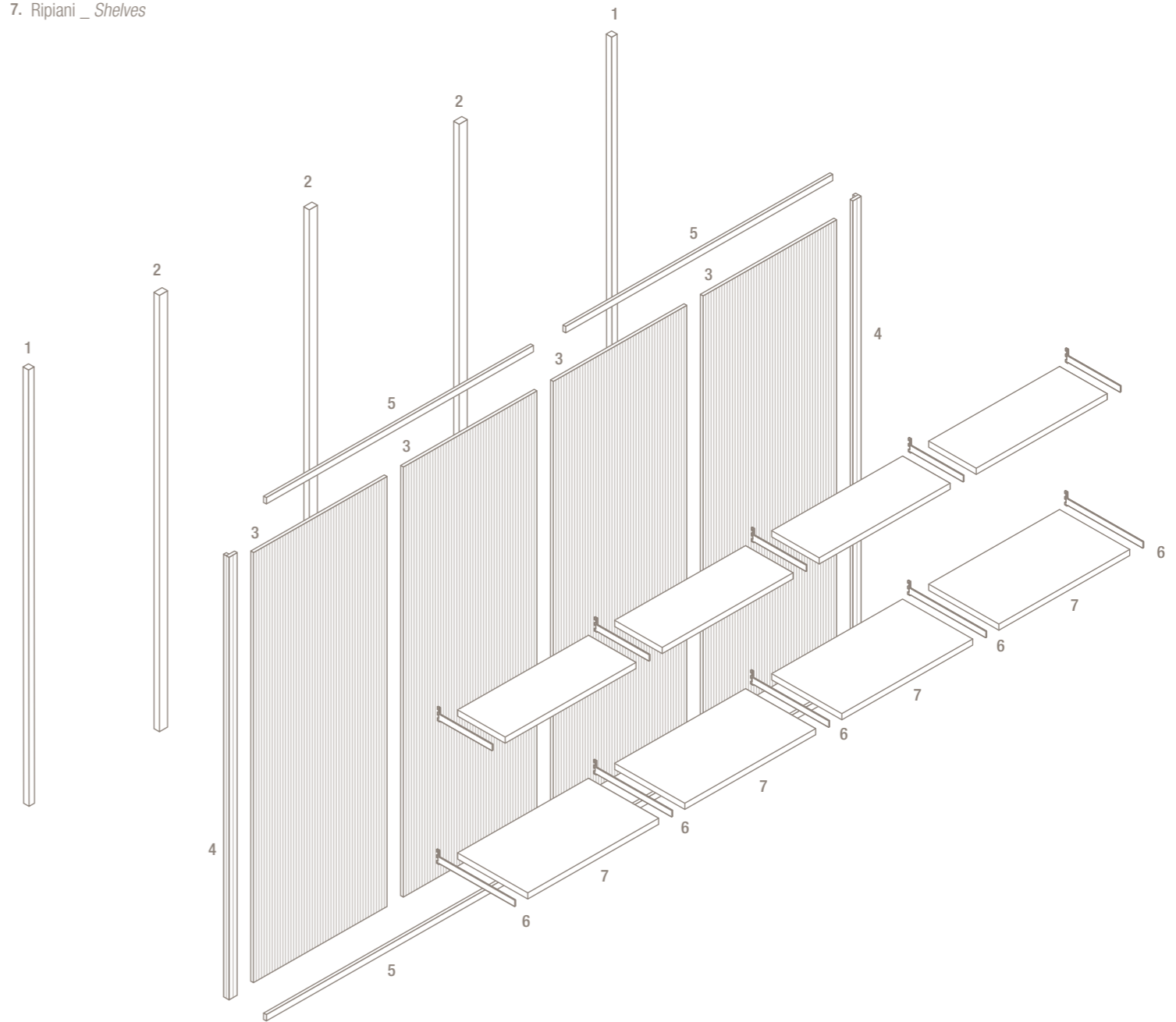

Dimensioni e componenti struttura _ *Dimensions and structure components*

TIPOLOGIE RIPIANI _ *SHELVES TYPOLOGIES*

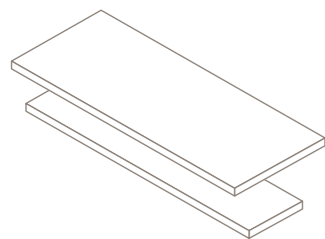

Ripiano Legno

Ripiano in particelle di legno nobilitato o laccato opaco
Sp. 38 mm, P. 340 mm e 546 mm.*

Wooden shelf

Chipboard shelf in melamine or matt lacquered Th. 1 1/2",
D. 13 3/8" and 21 1/2".*

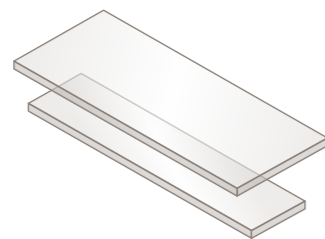

Ripiano Frame

Ripiano in vetro con telaio verniciato metallizzato
Sp. 38 mm, P. 340 mm e 546 mm.*

Frame shelf

Glass shelf with varnished metallised frame Th. 1 1/2",
D. 13 3/8" and 21 1/2".*

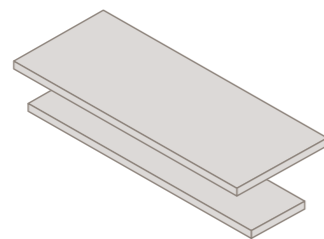

Ripiano Ecopelle

Ripiano in ecopelle con telaio verniciato metallizzato Sp. 38 mm,
P. 340 mm e 546 mm.*

Eco-leather Shelf

Eco-leather shelf with varnished metallised frame Th. 1 1/2",
D. 13 3/8" and 21 1/2".*

* I ripiani sono disponibili solo in misure standard, non sono riducibili come per pannelli boiserie
Shelves are only available in standard sizes, they are not reducible as for paneling panels

STAFFE PER FISSAGGIO RIPIANI _ *SHELF FIXING BRACKETS*

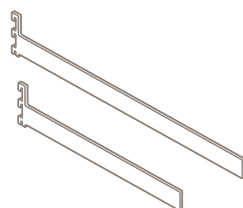

Staffa

Staffa in alluminio verniciato
P. 546 mm, Sp. 6 mm, H 38 mm
P. 340 mm, Sp. 6 mm, H 38 mm

Bracket

Varnished aluminum bracket
D. 21 1/2, Th. 1/4, H 1 1/2
D. 13 3/8, Th. 1/4, H 1 1/2

TIPOLOGIE PANNELLI BOISERIE _ *BOISERIE PANEL TYPOLOGIES*



Pannello uniforme

Pannello in particelle di legno utilizzato come supporto per finiture nobilitate, laccate, vetro e paglia. Sp. 22 mm, riducibile in larghezza e altezza al millimetro.

Uniform panel

Wood particle board used as support for melamine, lacquered, glass and woven straw finishes. Th. 22 mm / 7/8", can be reduced in width and height per millimeter (1/16").



Pannello Millerighe

Pannello MDF nero idrofugo rivestito con tranciato di legno o laccato opaco fresato su disegno personalizzato MisuraEmme 26+6 mm. Sp. 22 mm, riducibile in larghezza a passo 32 mm e in altezza al millimetro.

Slatted wood

Hydrophobic black MDF panel covered with wood veneer of matt lacquered milled to custom MisuraEmme design 26+6 mm. Th. 22 mm / 7/8", can be reduced in width to 32 mm / 1/4" pitch and height to the millimeter (1/16").

FOCUS ON TELAIO _ FOCUS ON FRAME

Palo Alto Wall è un sistema parete a boiserie che prevede due tipologie di montanti, iniziali/terminali e montanti centrali. I montanti si applicano a muro tramite appositi distanziali che ne permettono la regolazione in profondità. Il montante iniziale della composizione va applicato singolarmente, mentre i montanti centrali vengono forniti uniti al pannello.

Palo Alto Wall is a boiserie night system with two types of uprights, start/end and central uprights. The uprights are attached to the wall by means of special spacers that allow the adjustment in depth. The start upright of the composition must be applied individually, while the central upright is supplied united the panel.

I pannelli vengono fissati a muro grazie all'ausilio dei montanti in alluminio. Le regolazioni in altezza e profondità sono integrate sui montanti di alluminio permettendo gli allineamenti al millimetro sui pannelli di rivestimento. L'altezza massima dei pannelli è H. 2900 mm mentre per i montanti di fissaggio è H. 4000 mm; la differenza può essere colmata grazie a pannelli soprizzo accostabili in altezza come rivestimento.

The panels are fixed to the wall thanks to the help of the aluminium uprights. Height and depth adjustments are integrated into the aluminium uprights allowing alignments to the millimeter on the cladding panels. The maximum height of the panels is H. 2900 mm while for the fixing posts is H. 4000 mm; the difference can be filled thanks to top panels that can be combined in height as a coating.

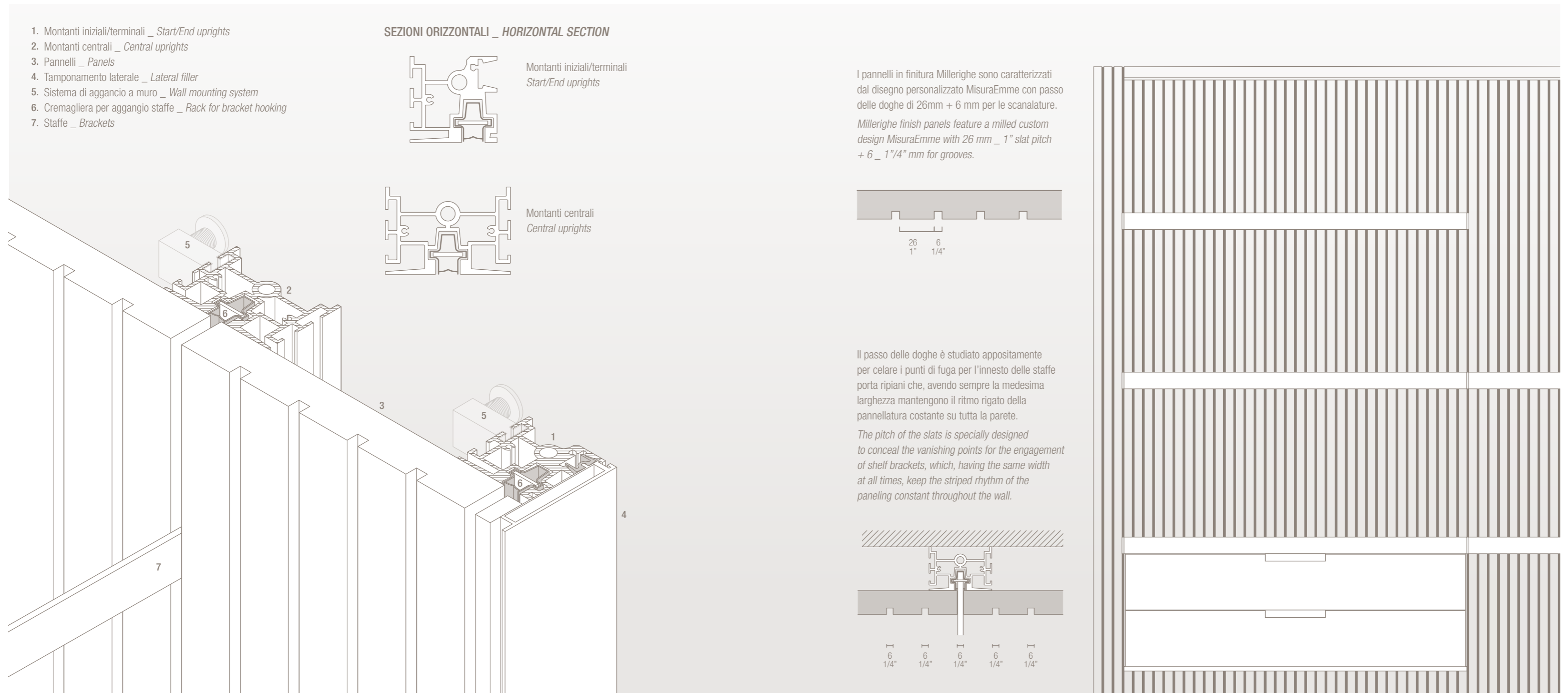

TAMPONAMENTI _ *FILLERS*

La struttura portante necessita sempre di fasce di tamponamento laterali e superiori, per integrarsi perfettamente con pareti in nicchia, lineari o ad angolo. Sono disponibili 4 tipologie di tamponamenti laterali dedicati a differenti soluzioni progettuali.

The supporting structure always needs lateral and upper fillers, to integrate perfectly with niche walls, linear or at an angle. There are 4 types of filler dedicated to different design solutions.

A Tamponamento con chiusura verticale.
Solo con montante iniziale/terminale.
Filler with vertical closure.
Only with initial/terminal upright.

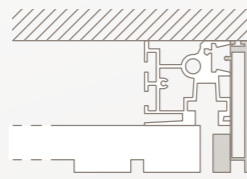

B Tamponamento per nicchia
Solo con montante centrale
Filer for niche.
Only with central upright

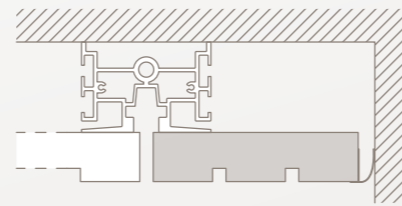

C Tamponamento a vista.
Solo con montante centrale.
Visible filler. Only with central upright.

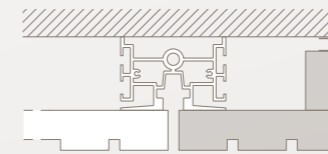

D Tamponamento con luce led.
Solo con montante centrale.
Filer with led light.
Only with central upright.

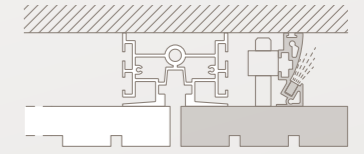

E Carter orizzontali superiori e inferiori di tamponamento con piede di regolazione in altezza e con possibilità di alloggiare luci led dimmerabili.
On the upper and lower horizontal carter with adjustable foot in height and with possibility of housing dimmable LED lights.

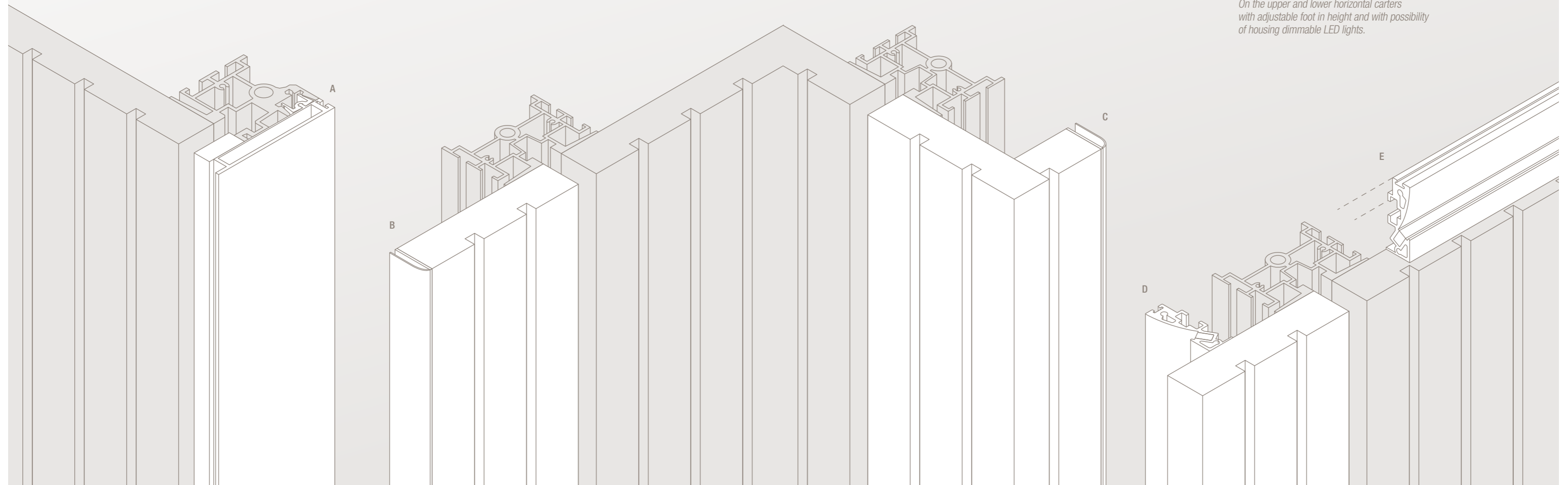

Finiture struttura _ *Structure finishings*



Finiture struttura _ Structure finishings

CARTER SUPERIORI/INFERIORI, TAMPONAMENTI LATERALI CON CHIUSURA VERTICALE E STAFFE _
 FRAME SIDE WITHOUT GLASS / FRAME SIDE WITH GLASS

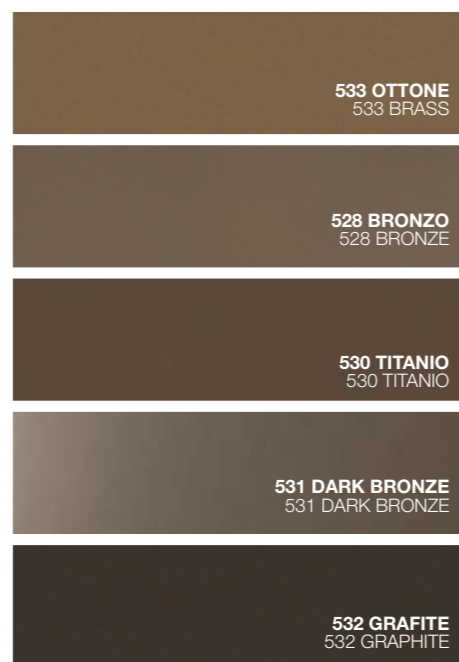
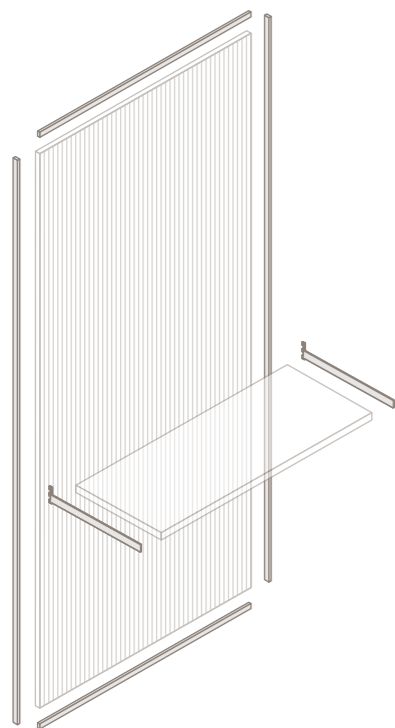

METALLI _ METALS

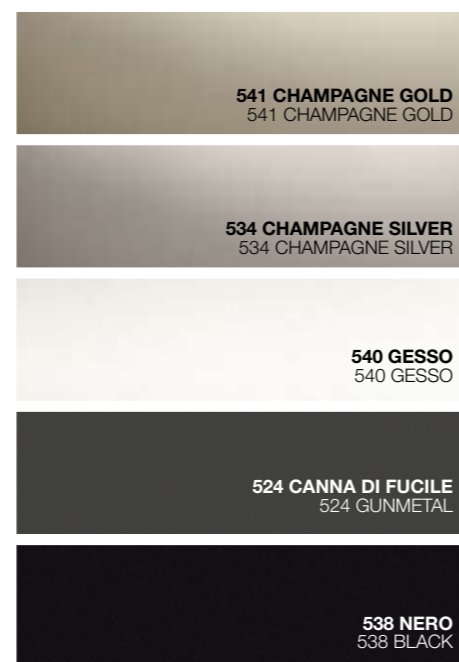

METALLI _ METALS

PANNELLATURA BOISERIE E TAMPONAMENTI _ BOISERIE PANELS AND FILLERS

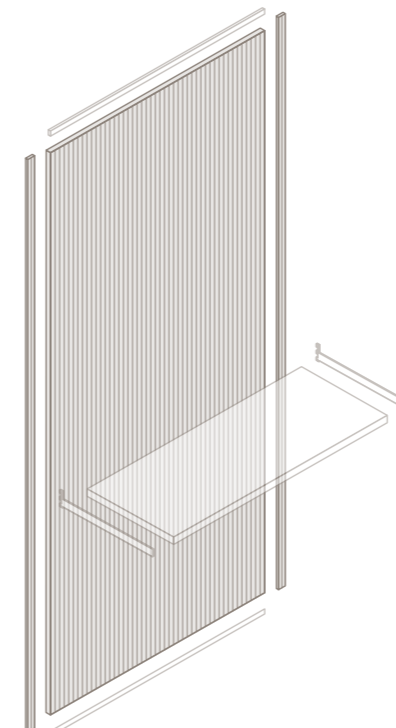

ESSENZE DOGATE _ SLATTED WOOD

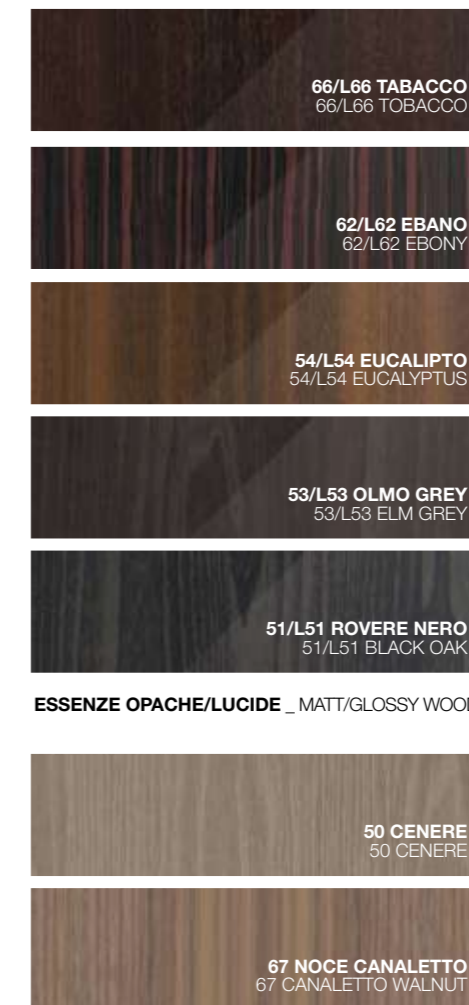

ESSENZE OPACHE _ MATT WOOD



NOBILITATI METALLIZZATI _ METALLIC MELAMINES

Accessori e dettagli struttura _ *Accessories and structure details*



Focus On

TIPOLOGIE TRAVERSI E SUPPORTI PER RIPIANI DELLE SPALLE TELAIO _ SUPPORT TYPOLOGIES FOR FRAME SIDES

Tramite l'uso di apposite staffe è possibile il fissaggio di mensole e ripiani direttamente sui montanti. Il sistema di aggancio delle staffe avviene su una cremagliera interna al montante nascosta da una guarnizione di protezione che assicura un risultato completamente invisibile e celato. Il passo dei ripiani è appositamente studiato per seguire al millimetro le stesse altezze degli altri sistemi Palo Alto e permette una perfetta integrazione con i sistemi **I-Box** e **Free**.

*Through the use of special brackets, it is possible to attach shelves directly to the uprights. The brackets coupling system occurs on an internal rack in the upright, which, thanks to a protective gasket ensures a completely invisible and concealed result. The gap of shelves is specially designed to precisely follow the same heights as other Palo Alto systems, allowing perfect integration with **I-Box** and **Free** systems.*

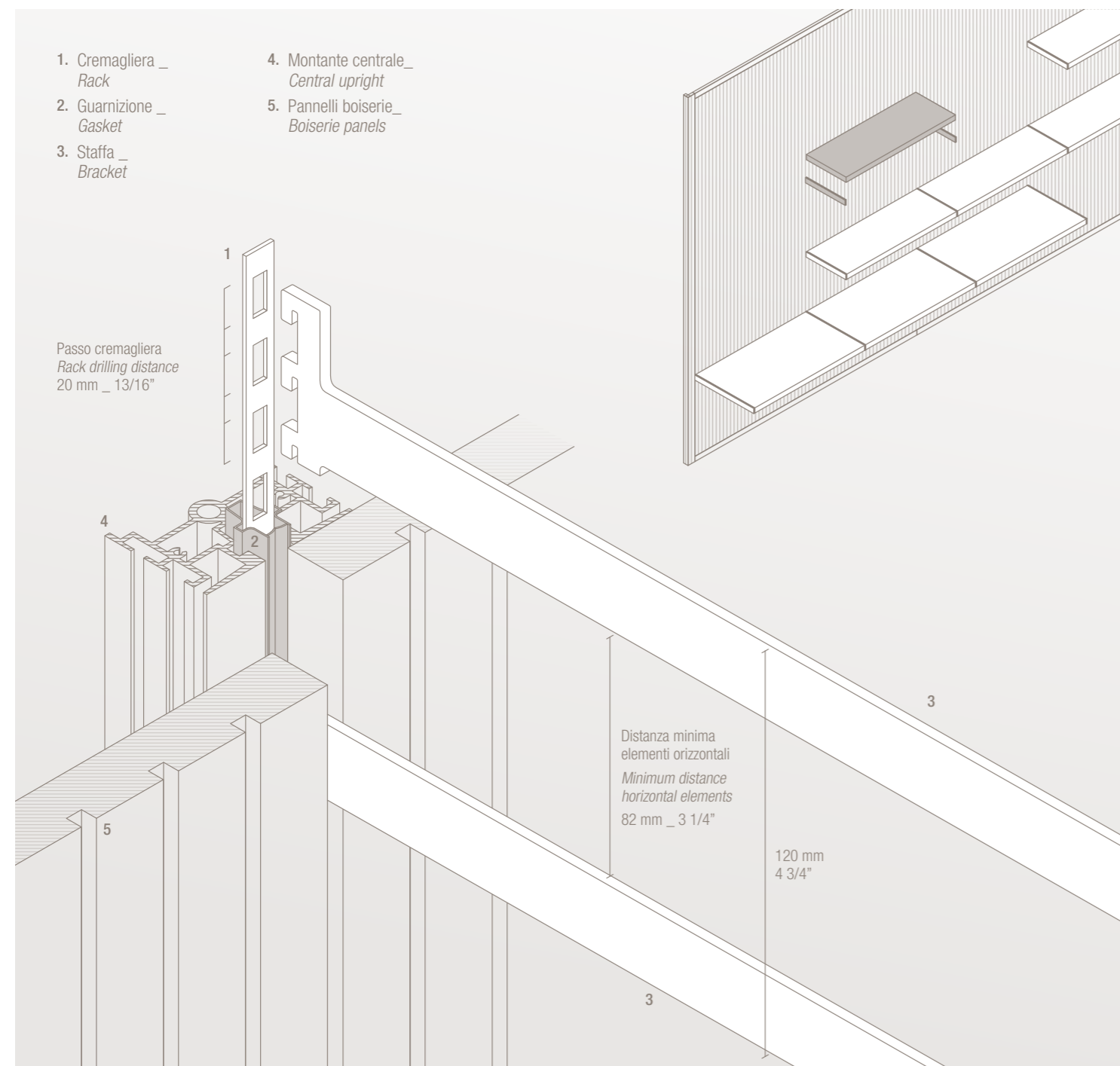

Impianto illuminazione _ *Lighting system*



Impianto illuminazione _ *Lighting system*

COMPONENTI IMPIANTO ILLUMINAZIONE _ *LIGHTING SYSTEM COMPONENTS*



Luce LED ZAFFIRO orizzontale per carter

Luce LED incassata nei carter superiori e inferiori, completo di cablaggio per collegamento. Lampade a gradazione calda 3000° K, a luce bianca 110 V o 220 V. Collegabili a dispositivo radio-comando, sensore oppure interruttore della stanza.

Carter horizontal LED LIGHT ZAFFIRO

Inserted LED light in the horizontal top and bottom carters supplied with a linking cable. Warm 3000K shade, 110 V or 220 V white lights. Connecting to a remote control or a detector or a switch in the room.



Luce LED ZAFFIRO verticale per tamponamenti laterali

Luce LED incassata nel tamponamento laterale, completo di cablaggio per collegamento. Lampade a gradazione calda 3000° K, a luce bianca 110 V o 220 V. Collegabili a dispositivo radio-comando, sensore oppure interruttore della stanza.

Vertical LED LIGHT ZAFFIRO for side fillers

Inserted LED light in the vertical side filler supplied with a linking cable. Warm 3000K shade, 110 V or 220 V white lights. Connecting to a remote control or a detector or a switch in the room.



Luce LED ZAFFIRO orizzontale per ripiani frame

Luce LED incassata nel ripiano orizzontale, completo di cablaggio per collegamento. Lampade a gradazione calda 3000° K, a luce bianca 110 V o 220 V. Collegabili a dispositivo radio-comando, sensore oppure interruttore della stanza. Disponibili anche per ripiani di elementi terminali ad angolo. Non è possibile inserire le lampade LED orizzontali per ripiani in presenza di schienali di vetro.

Horizontal LED LIGHT ZAFFIRO for wooden shelves

Inserted LED light in the horizontal shelf/top supplied with a linking cable. Warm 3000K shade, 110 V or 220 V white lights. Connecting to a remote control or a detector or a switch in the room. Also available for the shelves of corner terminal elements. It is not possible to insert horizontal LED lights for shelves with glass back panels.



Kit Radio-Comando _ *Remote-Control Kit*

È possibile controllare l'impianto di illuminazione tramite un kit Radio-comando oppure allacciare l'impianto direttamente all'interruttore della stanza, senza quindi l'ausilio di un radio-comando o di sensori di movimento.

It is possible to control the lighting system through a remote controller; it is also possible to directly connect the lighting plant to the switch in the room; therefore, without any remote control or moving detectors.

Focus On

PASSAGGIO CAVI _ WIRE PASSAGE

Impianto elettrico

L'impianto elettrico Palo Alto Wall prevede 3 soluzioni d'illuminazione:

- Per tamponamenti verticali iniziali / terminali
- Per carter orizzontali superiori / inferiori
- Per accessori orizzontali (ripiani legno e ripiani frame)

Light system

The electrical system Palo Alto Wall provides 3 lighting solutions:

- For initial vertical infills / terminals
- For upper/ lower horizontal casings
- For horizontal accessories (wooden shelves and frame shelves).

Impianto elettrico orizzontale per accessori

L'impianto elettrico orizzontale è composto dai led (luce continua) presenti sugli accessori, l'elettrificazione viene trasmessa grazie all'innovativo sistema a cremagliera elettrificata (patent pending) che permette di montare e spostare ripiani o accessori con illuminazione integrata in totale sicurezza, senza cavi o connessioni visibili.

Horizontal light system for accessories

Horizontal light system is composed by LEDs with continuous light applied on internal accessories; electrification is transmitted through the innovative electrified rack system (patent pending), which allows shelves or accessories with integrated lighting to be mounted and moved safely, without visible cables or connections.

Cremagliera elettrificata

Il sistema prevede l'inserimento nel montante in alluminio di una cremagliera in acciaio al carbonio, elettrificata a bassissima tensione (12-24V) e isolata tramite un estruso plastico in policarbonato ignifugo V0 UL-94. Per garantire la migliore conduzione elettrica, la cremagliera in acciaio è preventivamente sottoposta a uno speciale trattamento superficiale di ramatura e nichelatura.

Electrified rack

The system involves the insertion of a carbon steel rack electrified at very low voltage (12-24V) into the aluminum upright, the rack is insulated by means of a V0 UL-94 fireproof polycarbonate plastic extrusion. To ensure the best electrical conduction, the steel rack is previously subjected to a special surface treatment of copper plating and nickel plating.

Staffe con predisposizione per elettrificazione

Le staffe di supporto che trasmettono la corrente ai ripiani sono preventivamente sottoposte a uno speciale trattamento superficiale di ramatura e stagnatura che le rende conduttive, vengono poi successivamente ricoperte con vernice epossidica isolante lasciando esposto solo il punto di contatto per l'elettrificazione dei ripiani.

Brackets with electrical set-up

Shelves support brackets with electrical set-up to in order to conduct power are first subjected to a special surface treatment of copper plating and tin plating to make them conductive, they are then successively covered with insulating epoxy paint, leaving only the shelves contact point for electrification exposed.

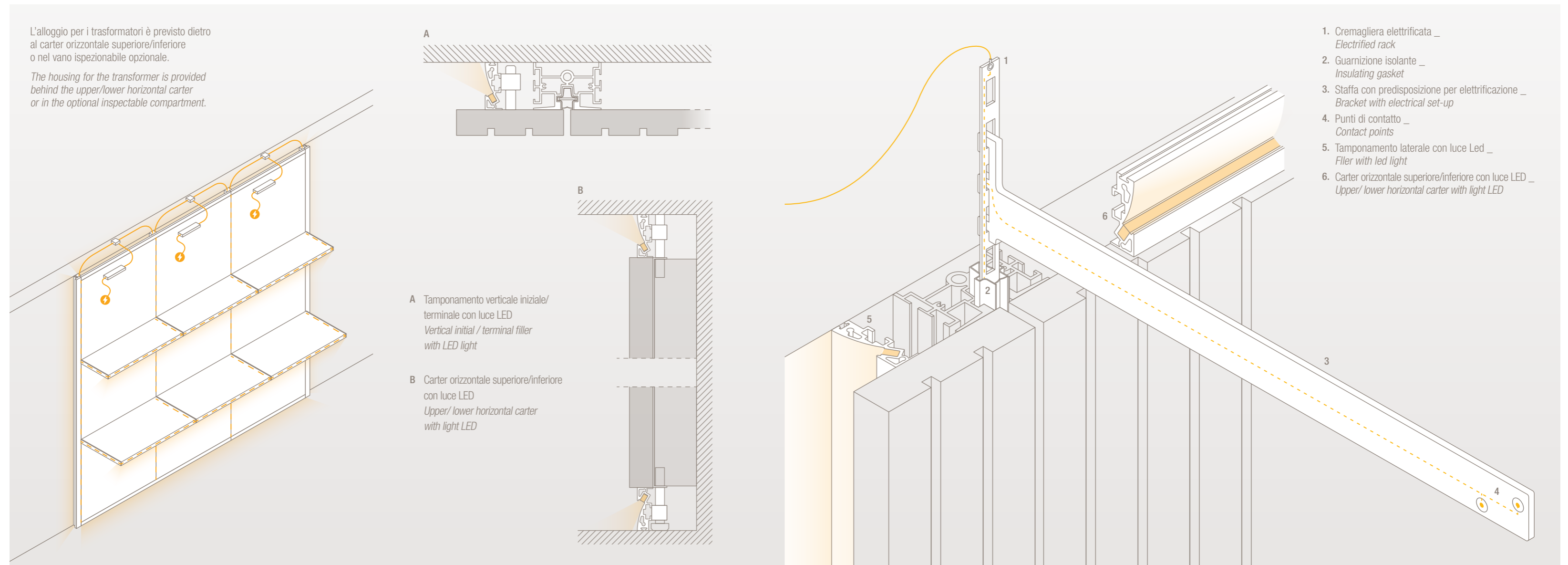

SOLUZIONI PROGETTUALI _ DESIGN SOLUTIONS

Sommario _ *Index*

- | | | | | | |
|-----|--|-----|---|-----|--|
| 224 | Angoli esterni, passaggi
porta e retro finito _
<i>External corners, doorways
and back finished panels</i> | 246 | Divisorio _ <i>Partitioning</i> | 270 | Ponti, sopralzi e mansarde _
<i>Bridges, overhangs attics</i> |
| 230 | Composizioni lineari _
<i>Linear compositions</i> | 250 | Angoli interni _
<i>Inside corners</i> | 274 | Cabine _ <i>Walk-in closet</i> |
| 234 | Finestre, passaggi porta
e colonne _ <i>Windows,
doorways and columns</i> | 260 | Vanity, vani a giorno
e contenitori _ <i>Vanity,
open compartments
and storage units</i> | | |
| 238 | Nicchie, tamponamenti
e riduzioni _ <i>Niches, fillers
and reductions</i> | 266 | Raccordi e integrazioni _
<i>Fittings and integrations</i> | | |

Soluzioni progettuali _ *Design solutions*

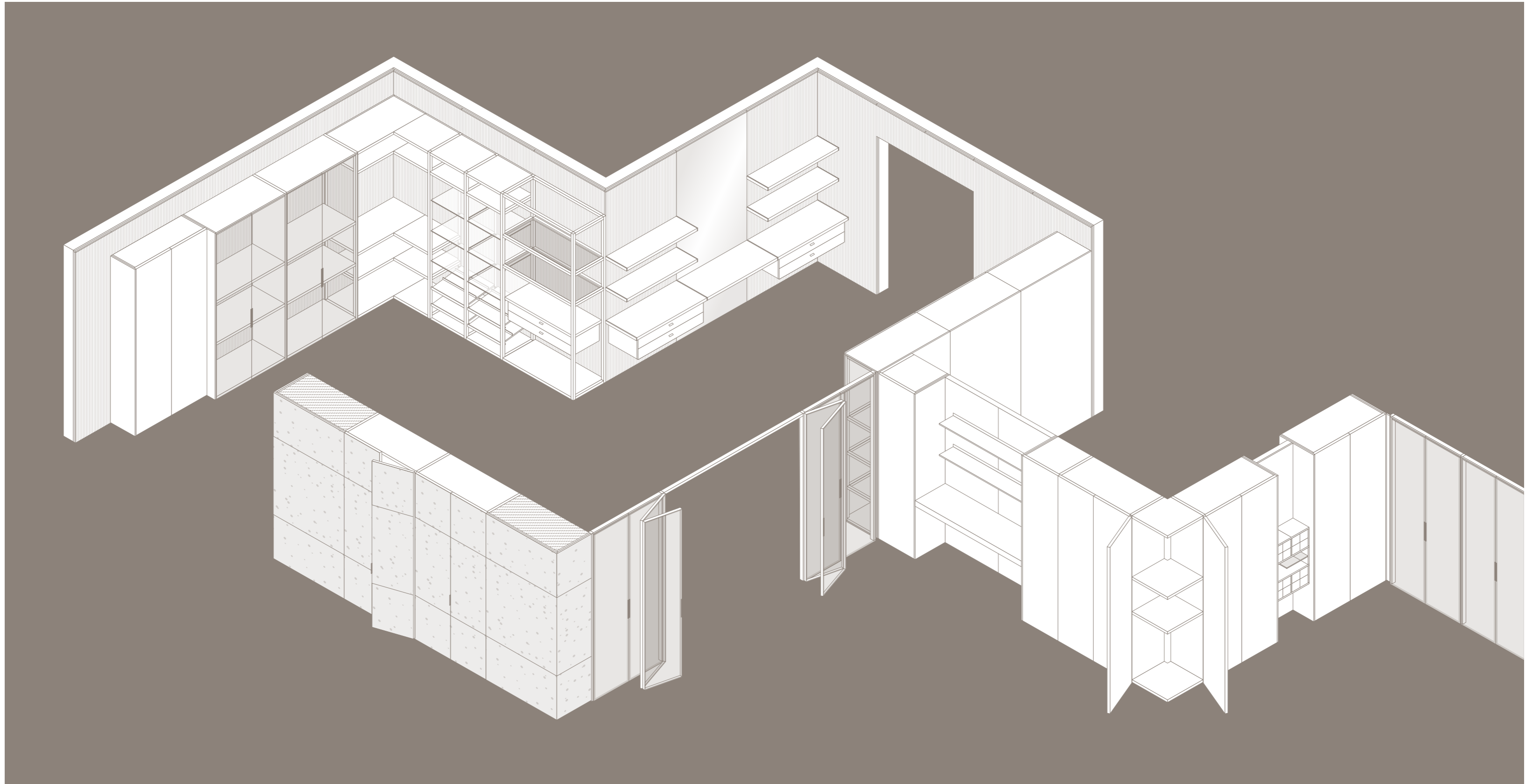

Angoli esterni, passaggi porta e retro finito _ *External corners, doorways and back finished panels***Descrizione**

In queste pagine integrazione tra sistema notte Palo Alto Wall con angolo interno e sistema notte Palo Alto I-Box con angolo esterno, passaggio porta con anta RX6 e pannellature retrofinito come schienali. Nelle pagine successive vengono descritte e approfondite per tutti i sistemi notte queste soluzioni progettuali.

On these pages integration between Palo Alto Wall night system with inside corner and Palo Alto I-Box night system with external corner, door passage with RX6 door and back-finished panel. In the following pages are described and explored these design solutions.

PALO ALTO I-BOX
ANGOLO ESTERNO _ EXTERNAL CORNER

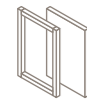

Soluzione I-Box disponibile per _
 I-Box solution available for:
SPALLE TELAIO _ SIDE FRAME
SPALLE LEGNO _ WOOD SIDE

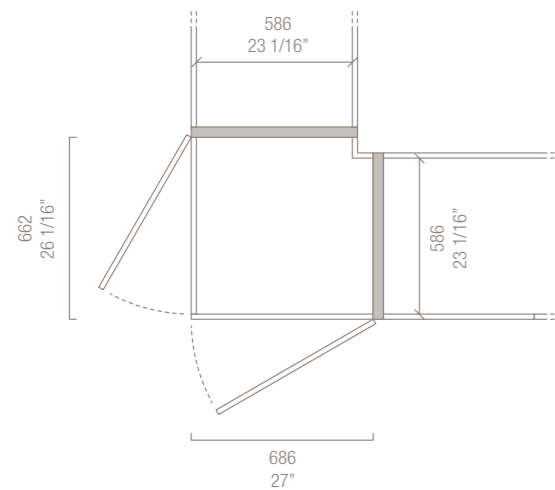
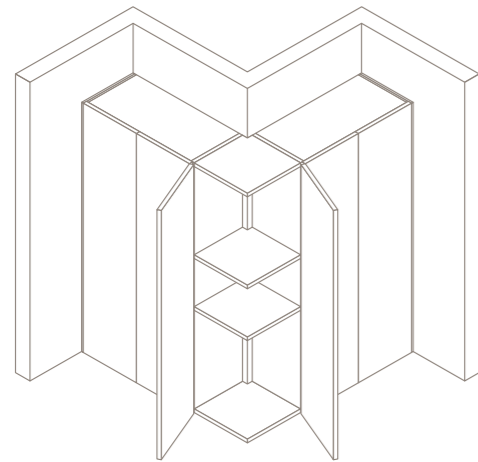

Soluzione disponibile tramite pilastro angolare di congiunzione. È quindi possibile creare soluzione ad angolo per armadi senza ante, battenti, scorrevoli e complanari.

Available solution through a small pillar on the corner. Therefore, it is possible to provide corner solutions through the use of a fixed door for wardrobes without doors, knockers, sliding and coplanar elements.

PALO ALTO FREE
ANGOLO ESTERNO _ EXTERNAL CORNER

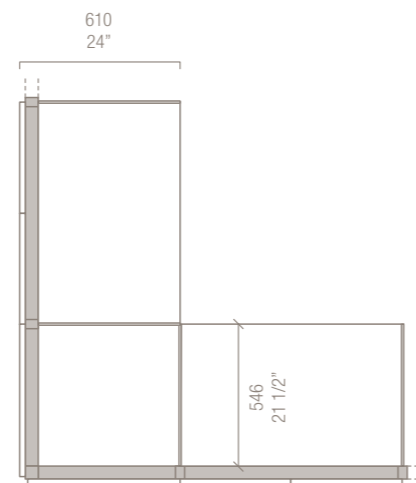
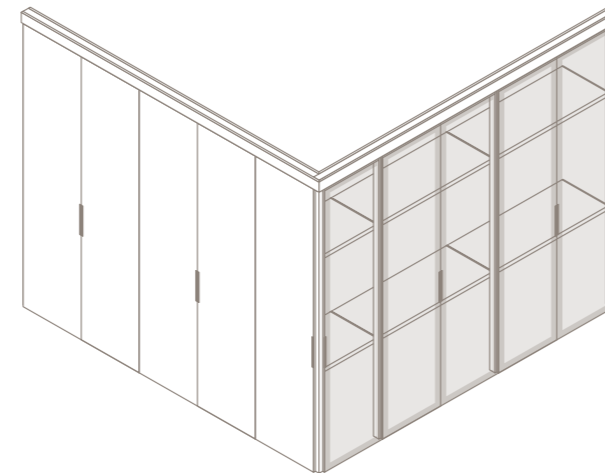

Soluzione ad angolo esterno per sistema notte Palo Alto Free ottenuta dall'intersezione di due composizioni lineari e tamponamenti di congiunzione dedicati.

External corner solution for Palo Alto Free night system obtained from the intersection of two linear compositions and dedicated joining fillers..

PALO ALTO WALL
ANGOLO ESTERNO _ EXTERNAL CORNER

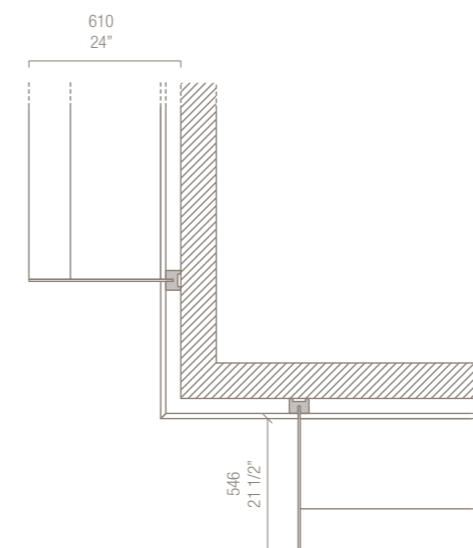
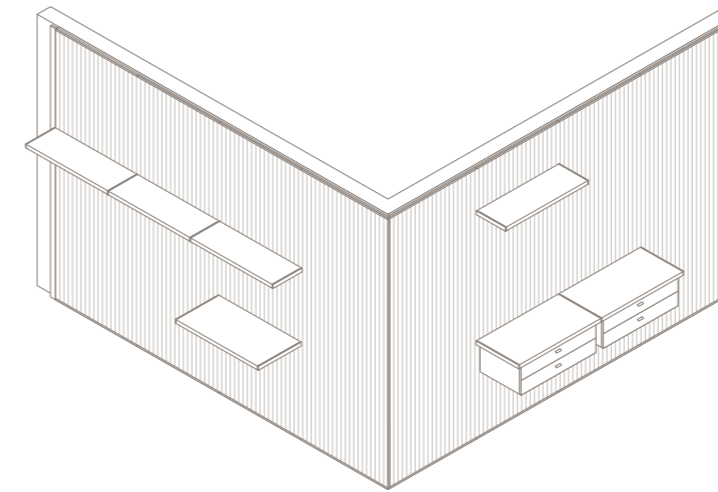

Soluzione ad angolo esterno per il sistema Palo Alto Wall, ottenuta da pannellatura dedicata di dimensione variabile. Tale pannellatura presenta nell'angolo una congiunzione dei pannelli a 45° con uno smusso di 6mm.

External corner solution for the Palo Alto Wall system, obtained from dedicated paneling of variable size. These panels are jointed in the corner at 45° with a 6mm bevel.

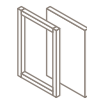
PALO ALTO I-BOX**PASSAGGIO PORTA _ DOOR PASSAGE**

PALO ALTO I-BOX
Soluzione disponibile per _ Solution available for:
SPALLE TELAIO _ SIDE FRAME
SPALLE LEGNO _ WOOD SIDE

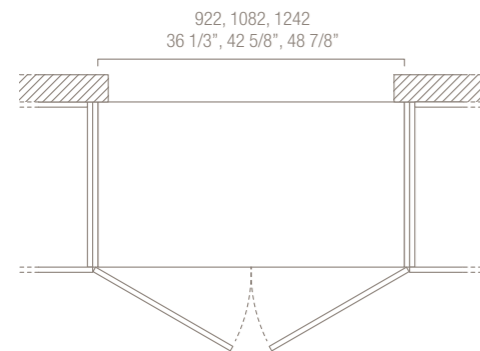
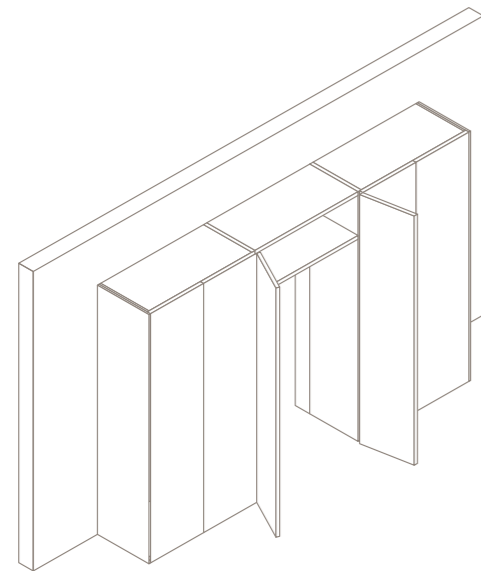

Soluzione realizzata con modulo senza basamento sia nella versione spalle legno, sia nella versione spalle telaio. Questa soluzione non è realizzabile con tipologie di aperture scorrevoli e coplanari. Nelle soluzioni con tipologie di aperture battenti non è possibile utilizzare le ante: Narcisse e Zeus. Dimensioni: L. 922 mm, 1082 mm, 1242 mm.

Solution obtained through a module without base both in the wooden side version and in the frame side one. This solution can not be provided with sliding and coplanar opening typologies. As far as the solutions with hinged door opening typologies are concerned, it is not possible to use the following doors: Narcisse and Zeus. Dimensions: L. 36 2/8", L. 42 5/8", L. 48 7/8".

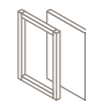
PALO ALTO I-BOX**PASSAGGIO PORTA RX6_ RX6 DOOR PASSAGE**

Soluzione I-Box disponibile per _
I-Box solution available for:
SPALLE TELAIO _ SIDE FRAME
SPALLE LEGNO _ WOOD SIDE

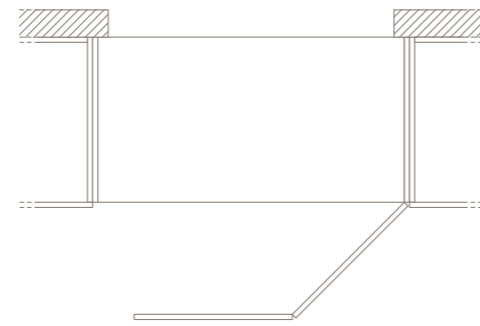
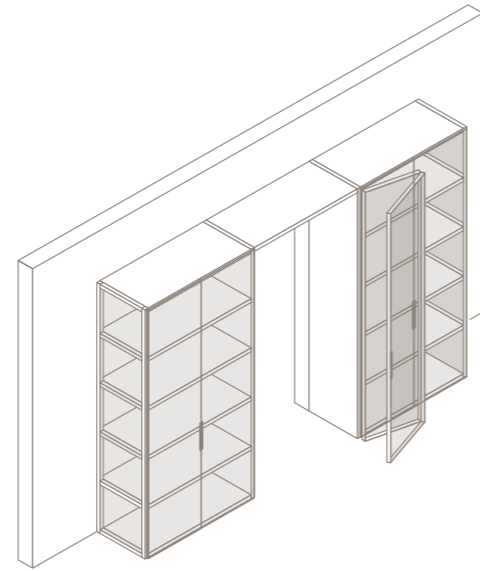

Possibilità di realizzazione di portali con apertura a "pantografo" che permette di traslare una o più coppie di ante dalla loro posizione di chiusura a quella di totale apertura a 180°, sovrapponendole alle ante del vano adiacente. La soluzione realizzata con modulo senza basamento sia nella versione spalle legno, sia nella versione spalle telaio. Realizzabile solo con ante Rex RX6.

Possibility of realization of portals with a "pantograph" opening door system that permits the movement of one or more pairs of doors from their closed position to total 180° opening, placed over the doors of the adjacent compartment. This solution is obtained through a module without base both in the wooden side version and in the frame side one. This solution is only feasible with Rex RX6 doors.

PALO ALTO I-BOX**ARMADIO BIFACCIALE _ BIFACIAL WARDROBE**

Soluzione I-Box disponibile per _
I-Box solution available for:
SPALLE TELAIO _ SIDE FRAME
SPALLE LEGNO _ WOOD SIDE

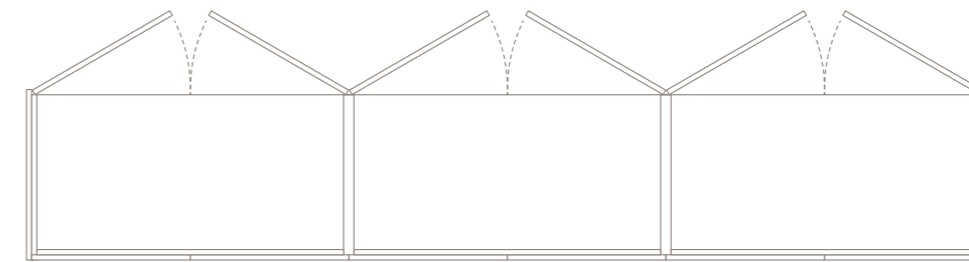
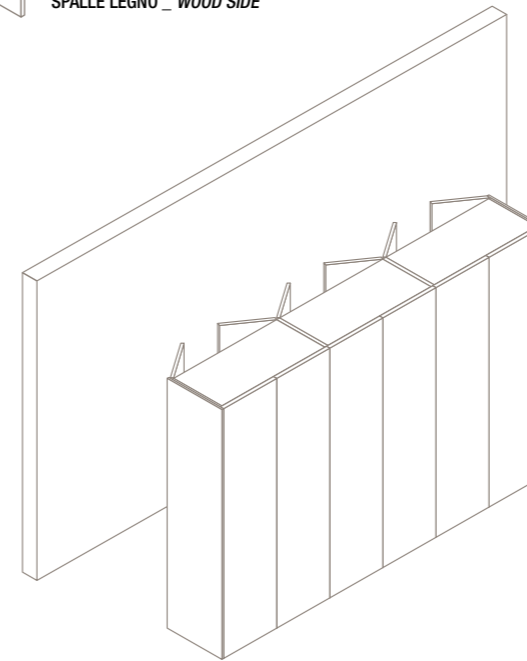

È possibile attrezzare il retro del sistema con le stesse ante della facciata, in modo da ottenere una bifaccialità, utile nel caso di posizionamento del sistema in centro stanza o come divisorio di ambienti. Non è possibile l'utilizzo delle ante: Narcisse, Zeus, Rex, Brillanta.

It is possible to supply the back of the system with the same doors of the frontal side, in order to obtain a double face useful when positioning the system in the middle of a room or as a partition element. It is not possible to use the following doors: Narcisse, Zeus, Rex and Brillanta.

Composizioni lineari _ *Linear compositions***Descrizione**

In queste pagine integrazione tra sistema notte Palo Alto I-Box con ante Puzzle e il sistema boiserie Puzzle. Composizione Palo Alto Wall lineare con moduli attrezzati e moduli boiserie.

Nelle pagine successive vengono descritte e approfondite per tutti i sistemi notte queste soluzioni progettuali.

On these pages integration between Palo Alto I-Box night system with Puzzle doors and Puzzle boiserie system. Palo Alto Wall linear composition with equipped modules and boiserie modules.

In the following pages are described and explored these design solutions.

PALO ALTO WALL
COMPOSIZIONE LINEARE _ LINEAR COMPOSITION

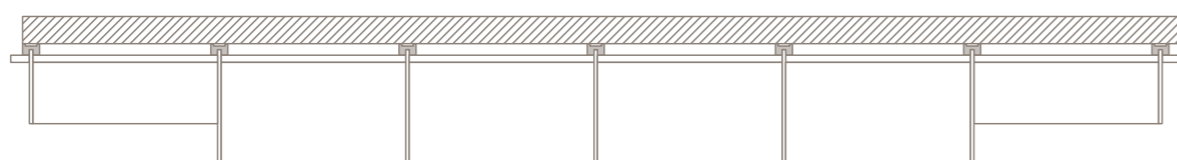
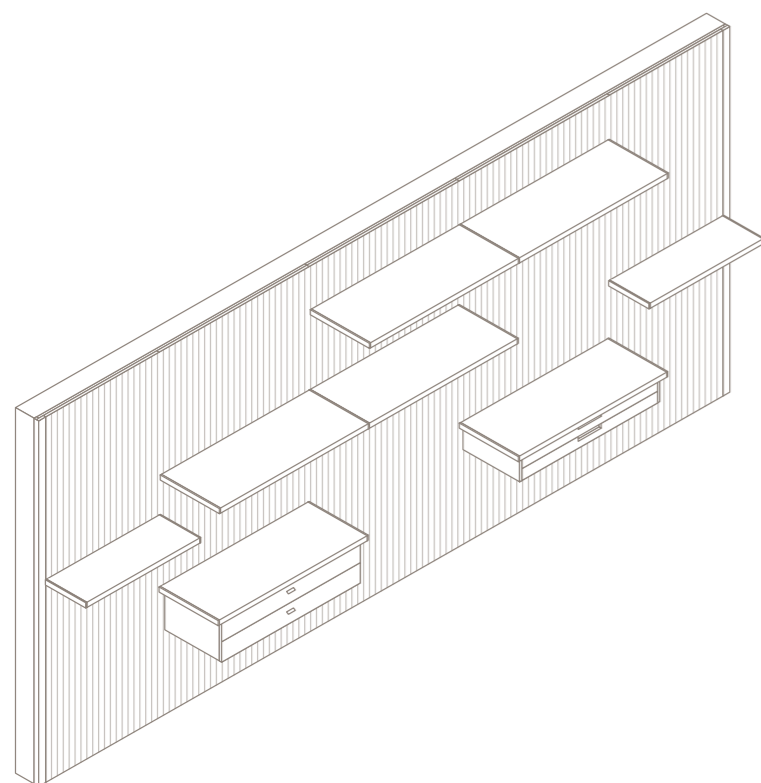

Soluzione lineare con Palo Alto Wall per il rivestimento di pareti in continuità estetica. Un rivestimento elegante in grado di esaltare le pareti e sfruttarne lo spazio al massimo delle sue potenzialità attraverso un'ampia gamma di accessori.

Linear solution with Palo Alto Wall for wall cladding in aesthetic continuity. An elegant wall covering that can enhance walls and exploit space to its full potential through a wide range of accessories.

PALO ALTO
INTEGRAZIONE CON ANTA/BOISERIE PUZZLE _ INTEGRATION WITH PUZZLE DOOR/BOISERIE

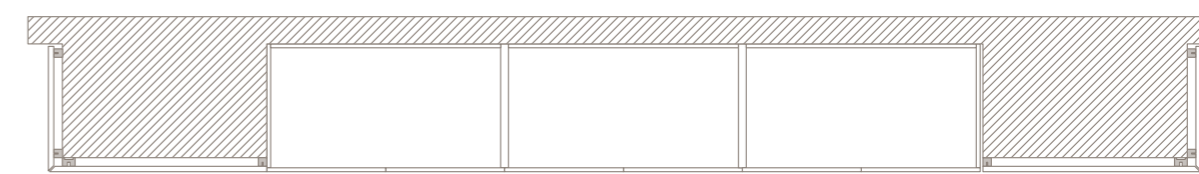
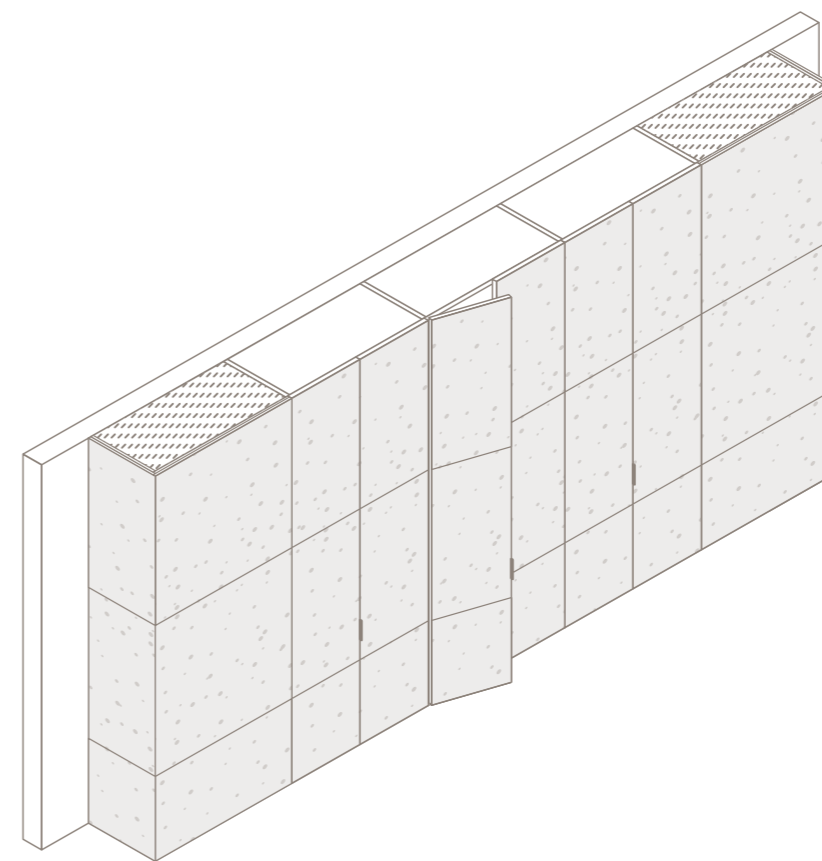

Soluzione d'integrazione tra il sistema Palo Alto I-Box il sistema boiserie Puzzle e ante Puzzle, trovando un perfetto punto d'incontro tra zona giorno e zona notte. Il rigoroso scandirsi della pannellatura nasconde le ante nel suo pattern lineare e facendole sembrare parte integrante dell'architettura circostante.

Integration solution between the Palo Alto I-Box system the Puzzle boiserie system and Puzzle doors, finding a perfect matching between living and sleeping areas. The rigorous rate of the paneling hides the doors in its linear pattern and making them look like an integral part of the surrounding architecture.

Finestre, passaggi porta e colonne _ Windows, doorways and columns**Descrizione**

In queste pagine viene mostrato l'utilizzo di Palo Alto Wall come sistema boiserie e sistema notte attrezzato più specificatamente come ottenere passaggi porta o rivestimenti di pareti attorno a finestre con Palo alto Wall.
Nelle pagine successive vengono descritte e approfondite per tutti i sistemi notte queste soluzioni progettuali.

Description

*These pages show how to use Palo Alto Wall as a boiserie and as night system equipped, more in detail how to achieve doorways or wall coverings around windows with Palo Alto Wall.
In the following pages are described and explored these design solutions.*

PALO ALTO I-BOX**MODULI PONTE TRA DUE ARMADI _
BRIDGE MODULE BETWEEN TWO WARDROBES**

Soluzione I-Box disponibile per _
I-Box solution available for:
SPALLE LEGNO _ WOOD SIDE

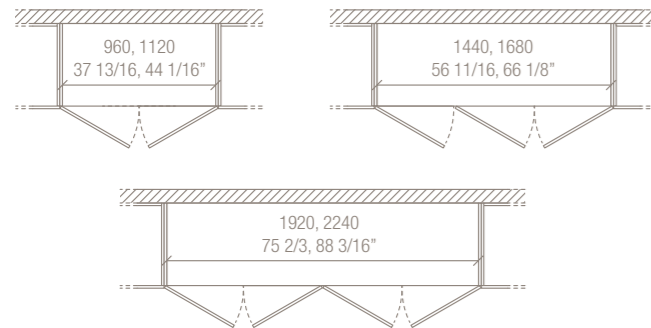
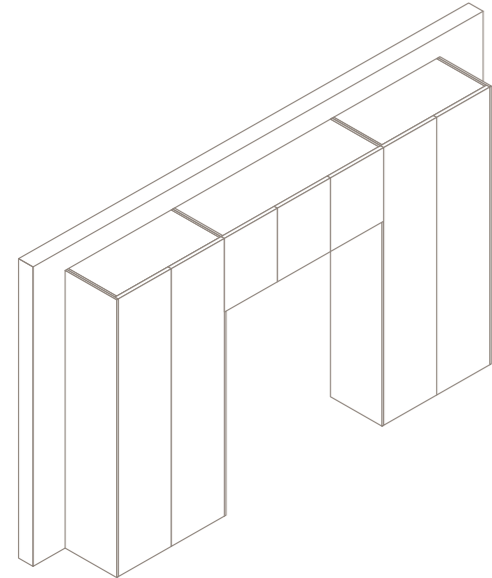

Ponte da interporre tra due armadi di P. 586 mm. Questa soluzione non è realizzabile con spalle telaio, tipologie di aperture scorrevoli e coplanari. Nelle soluzioni con tipologie di aperture battenti non è possibile utilizzare le ante: Narcisse, Zeus, Rex. È possibile completare il vano sottostante con schienali legno di finitura. Dimensioni: H 2262 mm, H 2422 mm, H 2582 mm, H 2742 mm, H 2902 mm. L 960 mm, L 1120 mm, L 1440 mm, L 1680 mm, L 1920 mm, L 2240 mm.

Bridge to insert between two wardrobes D. 23 1/8". This solution can not be provided through frame sides, sliding and coplanar opening typologies. As far as the solutions with hinged door opening typologies are concerned, it is not possible to use the following doors: Narcisse, Zeus, Rex. It is possible to complete the underneath case with finishing wooden back panels. Dimensions: H. 89", H. 95 3/8", H. 101 5/8", H. 108", H. 114 2/8", L. 37 6/8", L. 44 1/8", L. 44 7/8", L. 66 1/8", L. 75 5/8", L. 88 2/8.

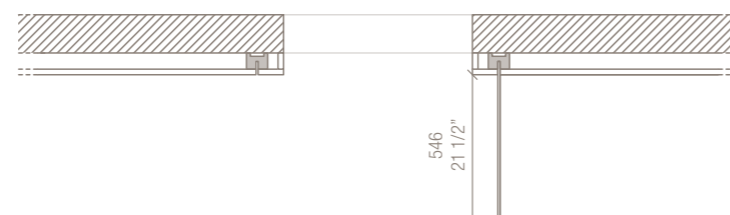
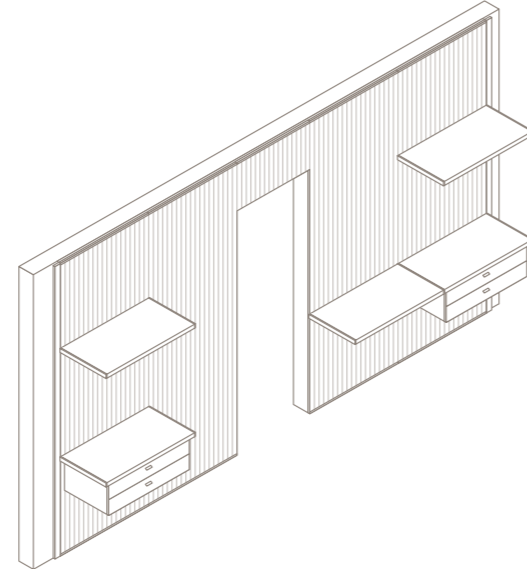
PALO ALTO WALL**PASSAGGIO PORTA _ DOOR PASSAGE**

Possibilità di contornare porte di dimensioni variabili mantenendo continuità visiva su tutta la parete. Completamente attrezzabile con accessori quali ripiani, cassettiere o illuminazione led. Modulo costituito da pannelli Sp. 22 mm sorretti dai montanti fissati a muro.

Possibility to surround doors of varying sizes, thus maintaining visual continuity throughout the wall. Fully equipable with accessories such as shelves and chests of drawers or led lighting. Consisting of 22 mm thick panels supported by the uprights fixed to the wall.

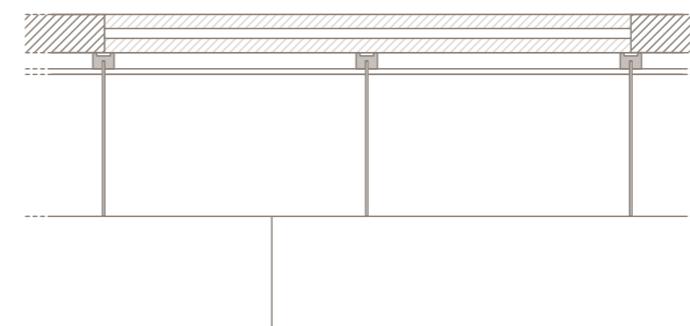
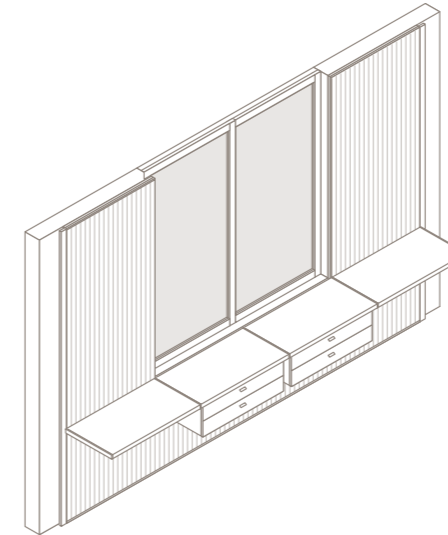
PALO ALTO WALL**MODULO FINESTRA _ WINDOW MODULE**

Possibilità di contornare finestre di dimensioni variabili mantenendo continuità visiva su tutta la parete. Completamente attrezzabile con accessori quali ripiani, cassettiere o illuminazione led. Modulo costituito da pannelli Sp. 22 mm sorretti dai montanti fissati a muro.

Possibility to surround windows of varying sizes, thus maintaining visual continuity throughout the wall. Fully equipable with accessories such as shelves and chests of drawers or led lighting. Consisting of 22 mm thick panels supported by the uprights fixed to the wall.

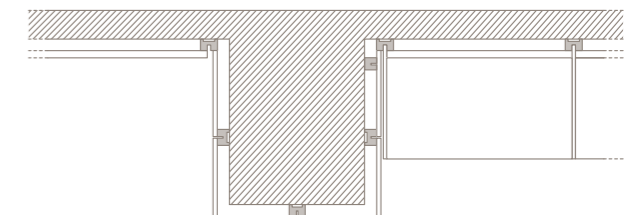
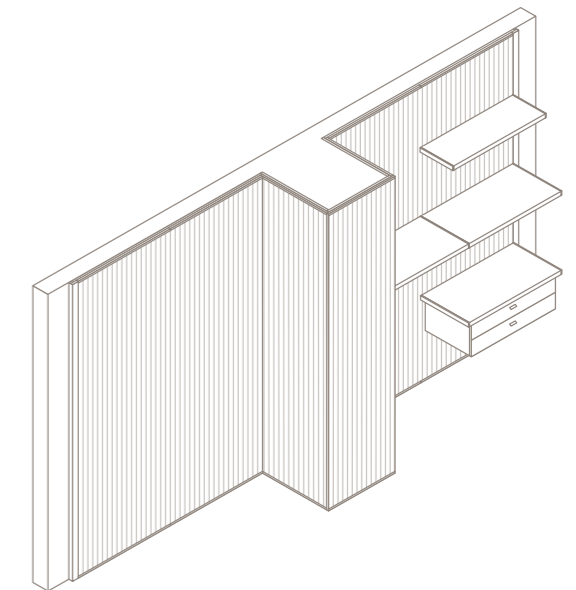
PALO ALTO WALL**SOLUZIONI COLONNA _ COLUMNS SOLUTIONS**

Possibilità di avvolgere colonne o elementi architettonici di dimensioni variabili e consentendo di mantenere continuità visiva su tutta la parete. Completamente attrezzabile con accessori quali ripiani, cassettiere o illuminazione led. Modulo costituito da pannelli Sp. 22 mm sorretti dai montanti fissati a muro.

Possibility to wrap around columns or architectural elements of varying sizes and allowing visual continuity to be maintained throughout the wall. Fully equipable with accessories such as shelves and chests of drawers or led lighting. Consisting of 22 mm thick panels supported by the uprights fixed to the wall.

Nicchie, tamponamenti e riduzioni _ *Niches, fillers and reductions***Descrizione**

In queste pagine viene mostrato l'utilizzo di Palo Alto Free all'interno di una nicchia per mettere in evidenza la flessibilità del sistema Palo Alto Free nella sua possibilità di ridursi su misura o di tagliare la fascia di tamponamento al fine di adattarsi alla nicchia esistente. Nelle pagine successive vengono descritte e approfondite per tutti i sistemi notte queste soluzioni progettuali.

Description

These pages show the use of Palo Alto Free within a niche to highlight the flexibility of the Palo Alto Free system in its ability to reduce size or to cut the filler strip in order to fit into the existing niche. In the following pages are described and explored these design solutions.

PALO ALTO FREE

SOLUZIONE IN NICCHIA _ NICHE SOLUTION

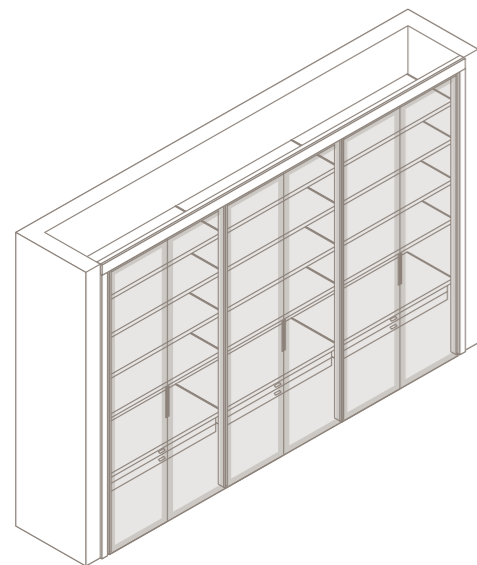

Possibilità di realizzazione di armadi in nicchia adattando perfettamente il sistema Free alle dimensioni della nicchia grazie all'uso di fasce di tamponamento superiori e laterali. I tamponamenti laterali frontali permettono di compensare da un minimo 60 mm fino a un massimo di 200 mm, i tamponamenti superiori frontali da 51 a 71 mm.

Possibility of fitting wardrobes and cabinets in niches by perfectly adapting the "Free" system to the dimensions of the space through the use of top and side fillers. Frontal side fillers allow for offsets from a minimum of 60 mm to a maximum of 200 mm, frontal top fillers from 51 to 71 mm.

PALO ALTO I-BOX

FASCIA DI TAMPONAMENTO SUPERIORE _ TOP FILLER



PALO ALTO I-BOX
Soluzione disponibile per _ Solution available for:
SPALLE TELAIO _ SIDE FRAME
SPALLE LEGNO _ WOOD SIDE

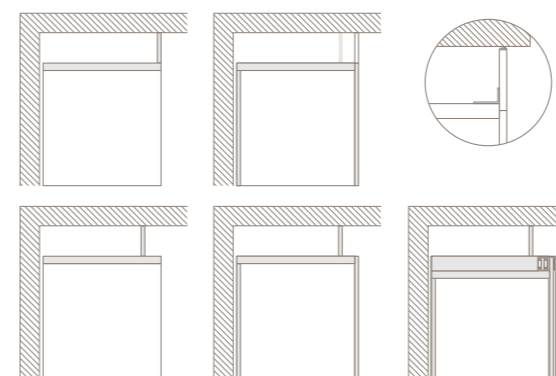
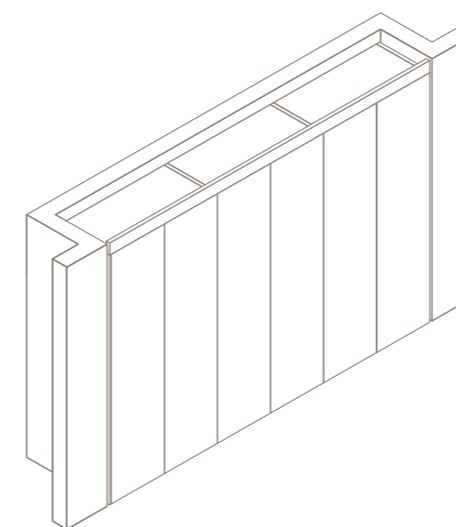

Fascia di tamponamento superiore a filo anta. Attrezzabile con profilo compensatore di gomma per chiusura parete fuori squadra. Non è possibile utilizzare la fascia di tamponamento superiore con soluzioni a tipologia di apertura coplanare.
Dimensioni: H. da 60 mm a 320 mm. L. fino max. 3000 mm.

Door height top filler. Supplying with a rubber and a compensating profile to close up. It is not possible to use the top filler with coplanar opening solutions. Dimensions: from H. 2 3/8" to H. 12 5/8" ; up to max L. 118 1/8".

PALO ALTO I-BOX

ANTA SU MISURA PER TAMPONAMENTO _ TAILORED HINGE DOOR TO FILLER



PALO ALTO I-BOX
Soluzione disponibile per _ Solution available for:
SPALLE TELAIO _ SIDE FRAME
SPALLE LEGNO _ WOOD SIDE

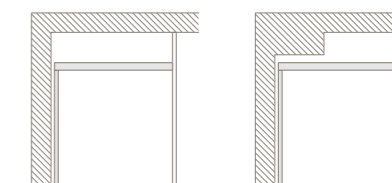
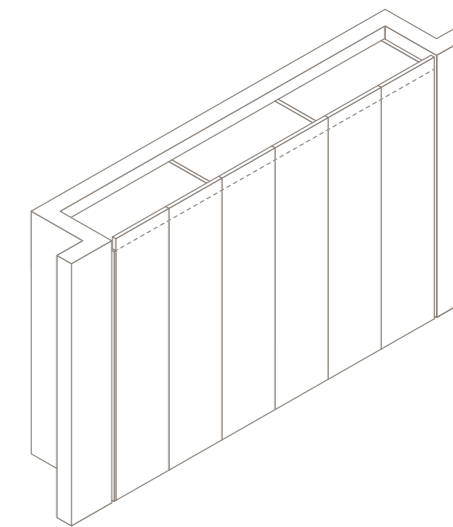

Possibilità di avere ante più alte rispetto alla struttura. Questa soluzione non è realizzabile con tipologie di apertura scorrevoli e coplanari. Nelle soluzioni con tipologie di aperture battenti non è possibile utilizzare le ante: Narcisse, Zeus, Rex.

It is possible to have doors taller than the structure. This solution is not possible with sliding and coplanar opening typologies. In the hinged door typologies, it is not possible to use the following doors: Narcisse, Zeus, Rex.

PALO ALTO I-BOX

**TAMPONAMENTO AD ANTA APRIBILE _
OPENING DOOR FILLER**

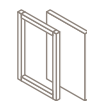

PALO ALTO I-BOX
Soluzione disponibile per _ Solution available for:
SPALLE TELAIO _ SIDE FRAME
SPALLE LEGNO _ WOOD SIDE

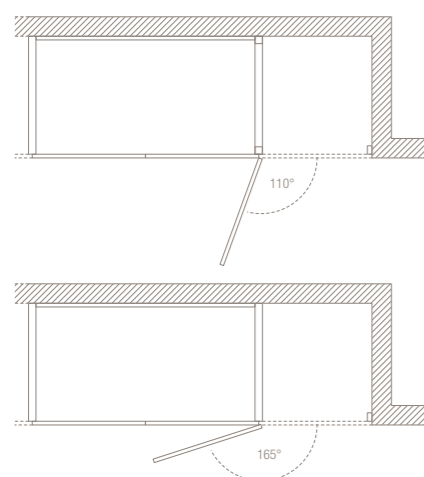
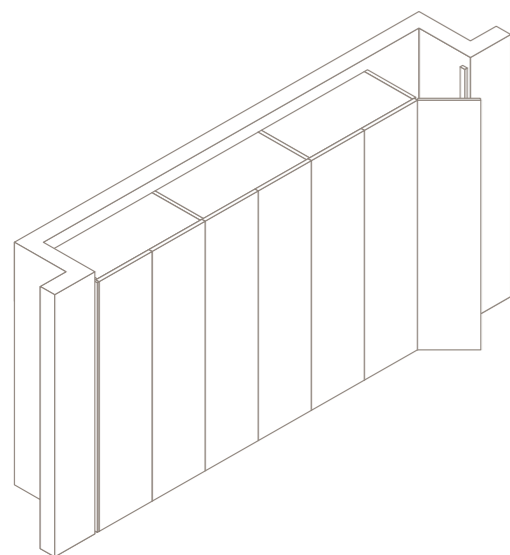

Possibilità di creare lateralmente un vano apribile con anta battente a misura. Cerniere dx o sx e pilastro di battuta a muro. Possibilità di attrezzare l'anta con un profilo compensatore di gomma per chiusura parete fuori squadra. Possibilità di chiusura push-pull.

It is possible to laterally provide an opening case with a tailored hinged door. Left or right zips and a wall pillar supplying with a rubber and a compensating profile to close up. Push-pull closure available.

PALO ALTO I-BOX

**FASCIA DI TAMPONAMENTO LATERALE _
SIDE FILLER**



PALO ALTO I-BOX
Soluzione disponibile per _ Solution available for:
SPALLE TELAIO _ SIDE FRAME
SPALLE LEGNO _ WOOD SIDE

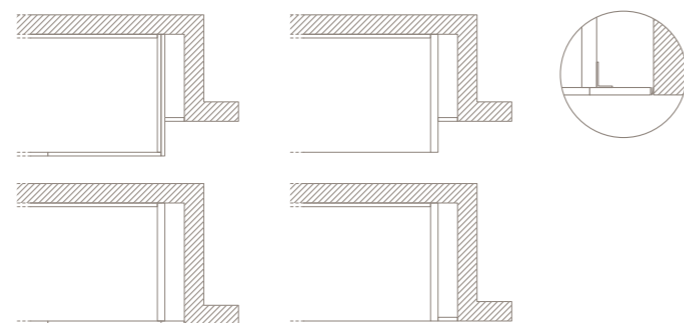
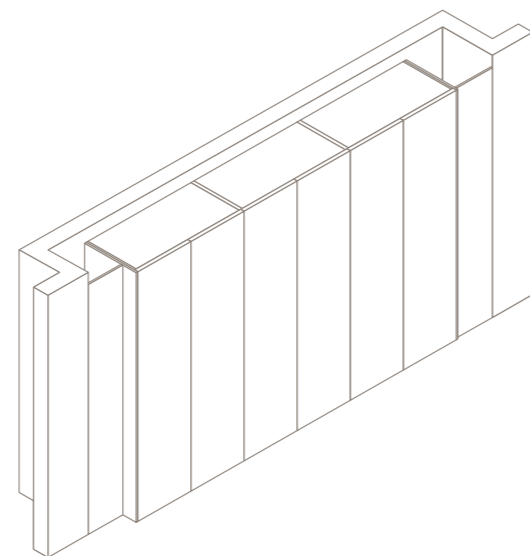

Fascia di tamponamento laterale utilizzabile a filo anta o lungo la struttura. Attrezzabile con profilo compensatore di gomma per chiusura parete fuori squadra. Il posizionamento della fascia di tamponamento laterale lungo la struttura, non è possibile in presenza di spalla telaio. Dimensioni: L. da 60 mm a 476 mm. H. fino max. 3000 mm.

Side filler which can be used along the door or the structure. Supplying with a rubber and a compensating profile to close up. The positioning of the side filler along the structure is not possible with a frame side. Dimensions: from W. 2 3/8" to W. 18 6/8"; up to max. H. 118 1/8".

PALO ALTO I-BOX

RIDUZIONI & SAGOMATURE _ REDUCTIONS & MOULDINGS



PALO ALTO I-BOX
Soluzione disponibile per _ Solution available for:
SPALLE TELAIO _ SIDE FRAME
SPALLE LEGNO _ WOOD SIDE



Soluzione I-Box disponibile per _
I-Box solution available for:
SPALLE LEGNO _ WOOD SIDE

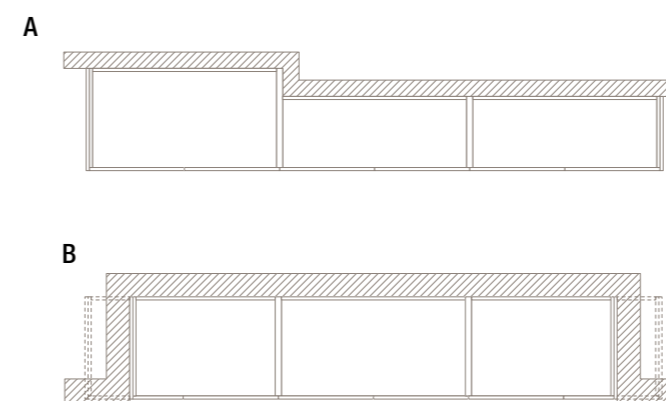
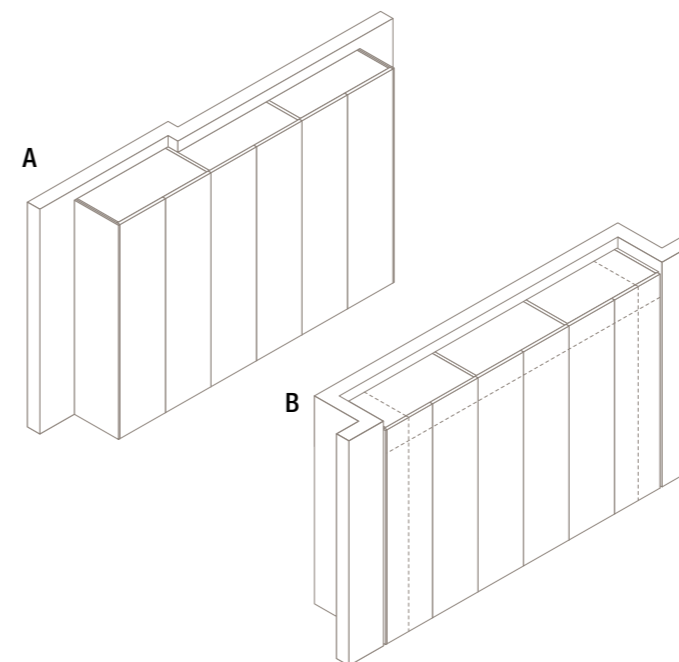

Sono possibili riduzioni in altezza, larghezza e profondità. Non è possibile la riduzione in altezza e in larghezza per le seguenti ante: Narcisse, Zeus, Rex, London. Non sono ammesse riduzioni in profondità per strutture con spalle telaio.

Possible reductions in height, width and depth. As for Narcisse, Zues, Rex and London doors a decrease in height and width is not possible. Reductions in depth for frame side structures not allowed.

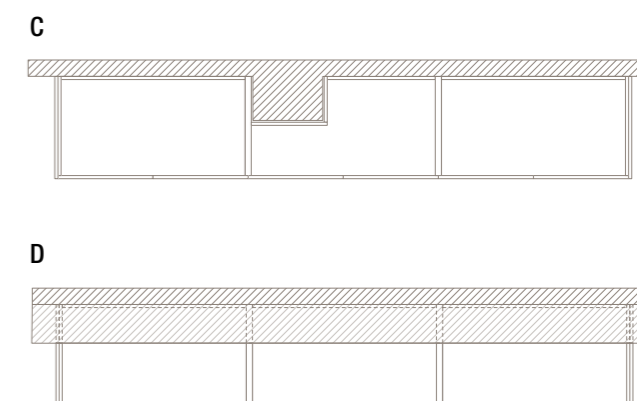
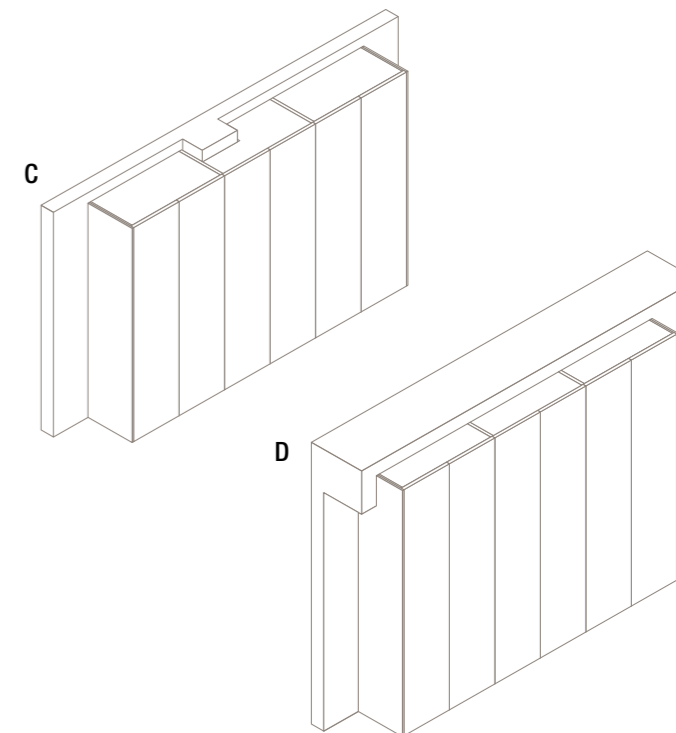

Sono possibili sagomature particolari in presenza di pilastri. Questa soluzione non è realizzabile per strutture con spalle telaio, tipologie di aperture scorrevoli e complanari.

Possible particular mouldings with pillars. Impossible for frame side structures, sliding and coplanar opening typologies.

PALO ALTO FREE

**TAMPONAMENTO A VISTA _
VISIBLE FILLER**

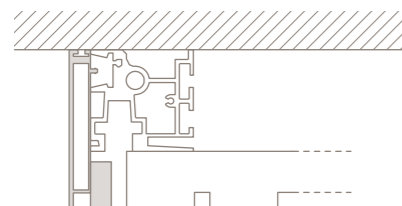
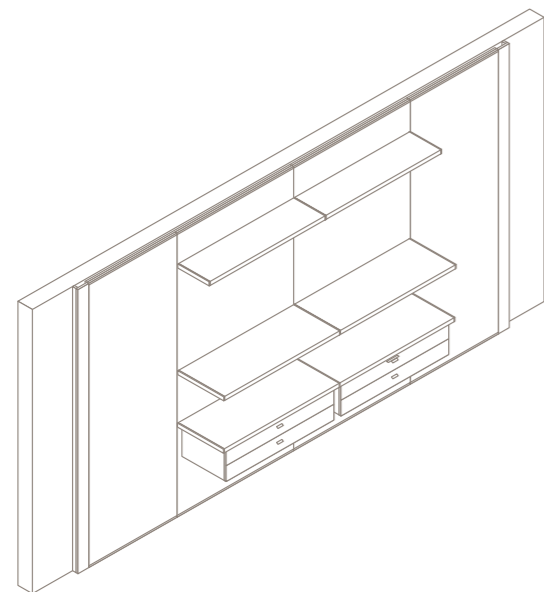

Tamponamento laterale con chiusura verticale con carter in finitura metallica. Solo con montante iniziale/terminale.

Side filler with vertical metal finish cover. Filler with vertical closure. Only with initial/terminal upright.

PALO ALTO I-BOX

**TAMPONAMENTO CON LUCE LED _
FILLER WITH LED LIGHT**

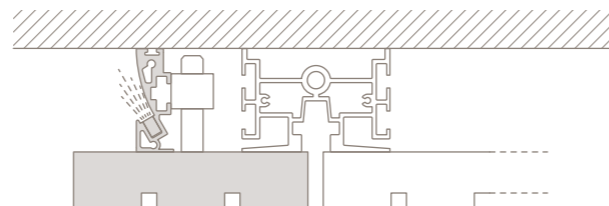
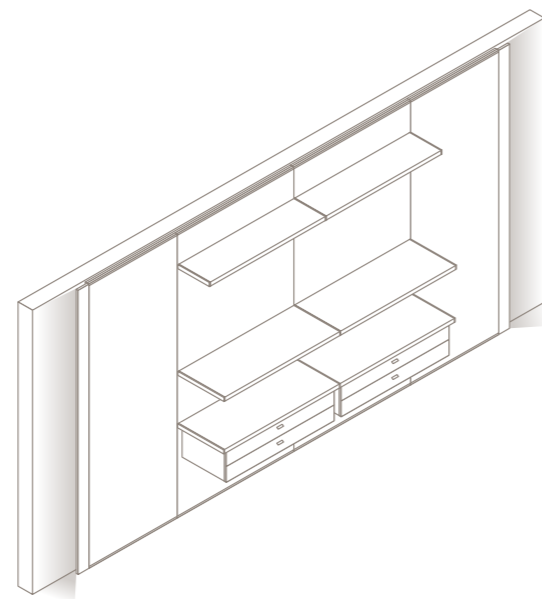

Tamponamento laterale con luce led, il sistema di illuminazione resta celato in maniera rientrata dietro la fascia di tamponamento, che a sua volta risulta completamente impercettibile essendo realizzata nella stessa finitura del resto della pannellatura. Applicabile solo con montante centrale.

Side filler with LED light, where the lighting system is concealed behind the filler panel, which itself completely unnoticeable being made in the same finish as the rest of the paneling. Only with central upright.

PALO ALTO I-BOX

**TAMPONAMENTO CON CHIUSURA VERTICALE _
FILLER WITH VERTICAL CLOSURE**

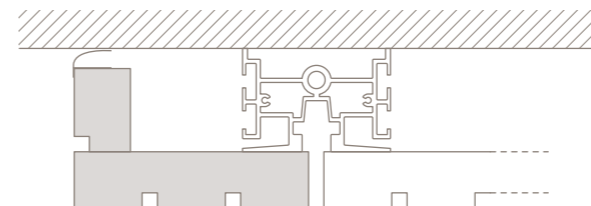
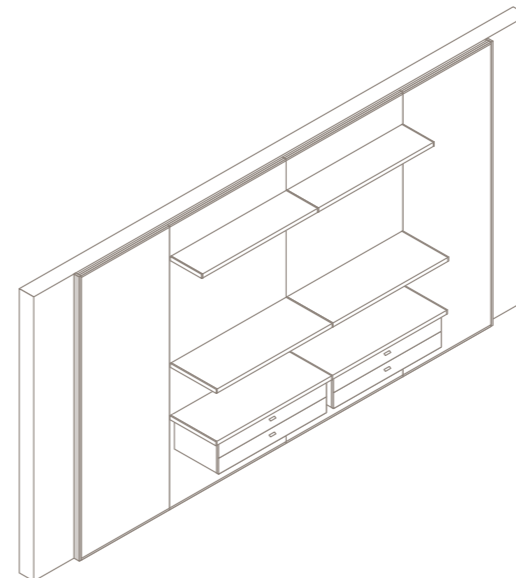

La fascia di tamponamento è composta a "L" con il pannello nella stessa finitura della boiserie che avvolge e chiude il lato della struttura. Applicabile solo con il montante centrale.

Side filler with "L" shape, in the same finish as the paneling, it wraps and closes the side of the structure. Only with central upright.

PALO ALTO I-BOX

**TAMPONAMENTO PER NICCHIA _
FILLER FOR NICHE**

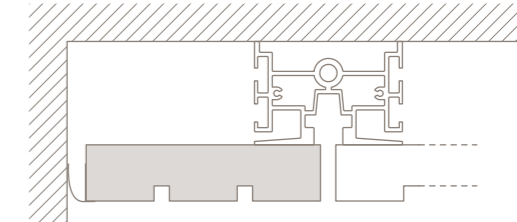
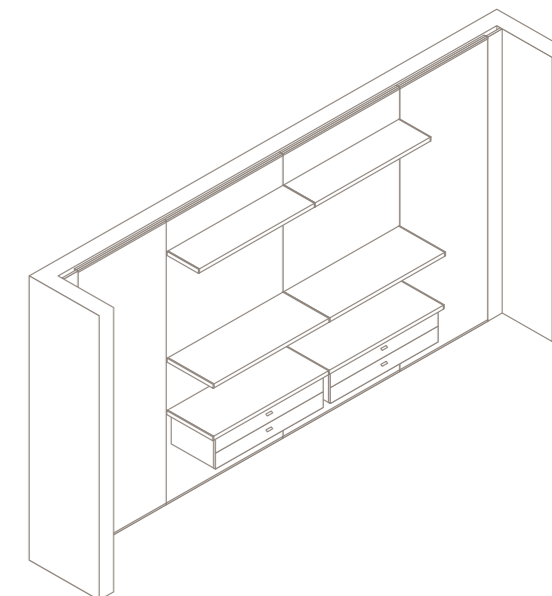

Tamponamento per nicchia, permette di chiudere la pannellatura fino a filo muro con la massima precisione e rimanendo completamente impercettibile essendo realizzato nella stessa finitura dal resto della pannellatura. Attrezzabile con un gommino opzionale e applicabile solo con montante centrale.

Niche filler made in the same finish as the paneling, it allows the paneling to be terminated flush with the wall with maximum precision and without being noticeable since it's completely indifferent from the rest of the paneling. Can be equipped with an optional rubber, available only with central upright.

Divisorio _ Partitioning**Descrizione**

In queste pagine viene mostrato l'utilizzo del sistema notte Palo Alto Free come elemento divisorio fra due ambienti. Nelle pagine successive vengono descritte e approfondite per tutti i sistemi notte queste soluzioni progettuali.

Description

These pages show the use of the Palo Alto Free night system as partition of two rooms. In the following pages are described and explored these design solutions.

PALO ALTO FREE
PASSAGGIO PORTA RX6 _ RX6 DOOR PASSAGE

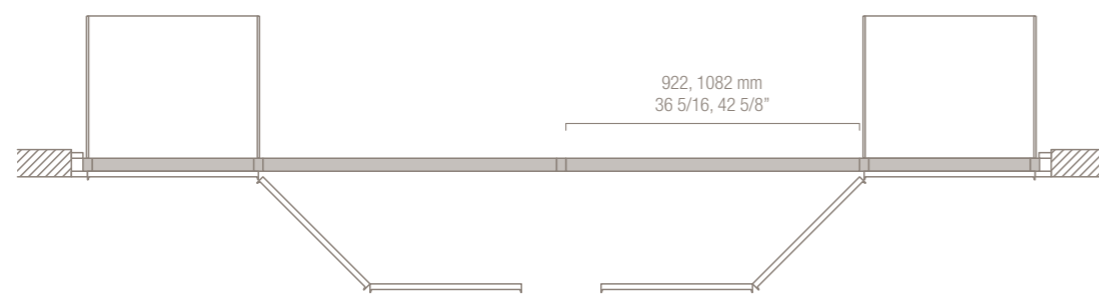
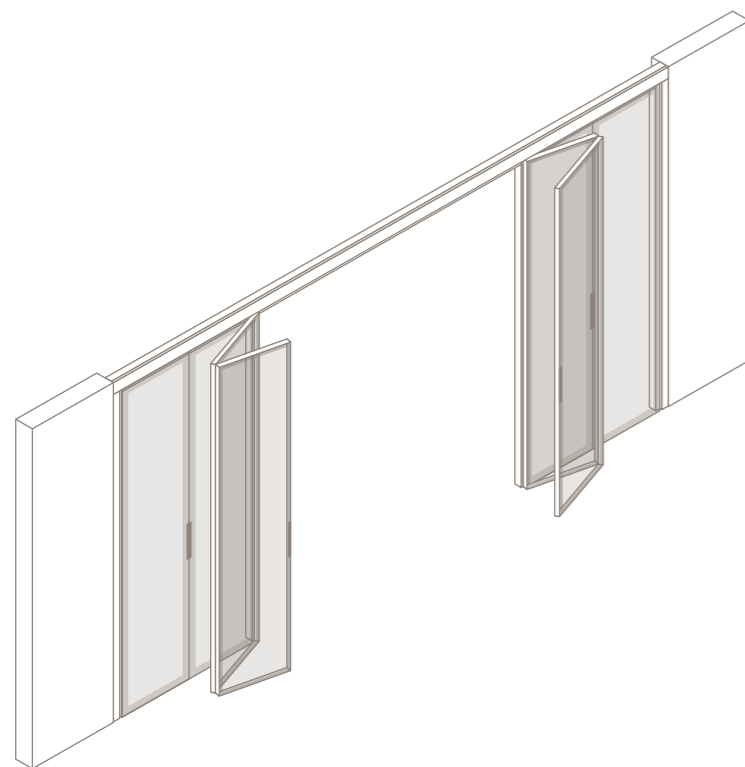

Sistema di porte con apertura a "pantografo" che permette di traslare una o più coppie di ante dalla loro posizione di chiusura a quella di totale apertura a 180°, sovrapponendole alle ante del vano adiacente. Una soluzione utile per dividere due ambienti o delimitare il perimetro della cabina armadio. La soluzione può essere realizzata con Palo Alto Free escludendo il montante centrale tra i due moduli del passaggio porta. Realizzabile solo con ante Rex RX6.

A "pantograph" opening door system that permits the movement of one or more pairs of doors from their closed position to total 180° opening, placed over the doors of the adjacent compartment. A useful solution for dividing two rooms or defining the perimeter of the walk-in closet. This solution can be obtained through without the central upright between the two doorway modules. It is only feasible with Rex RX6 doors.

PALO ALTO I-BOX
PASSAGGIO PORTA LAYER _ LAYER DOOR PASSAGE

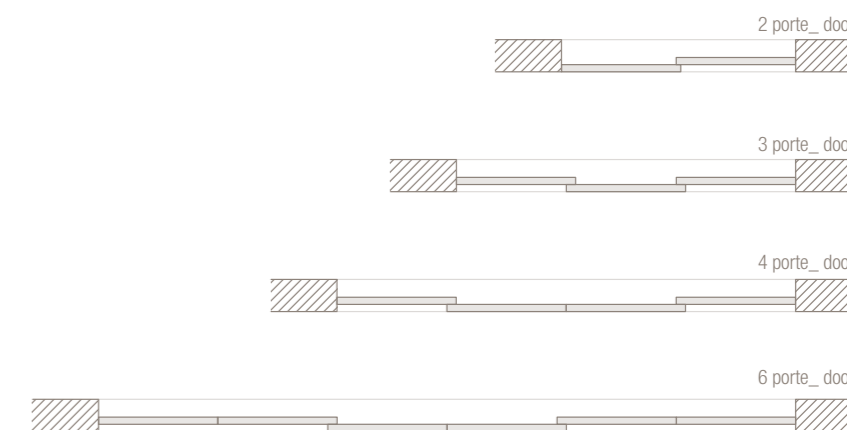
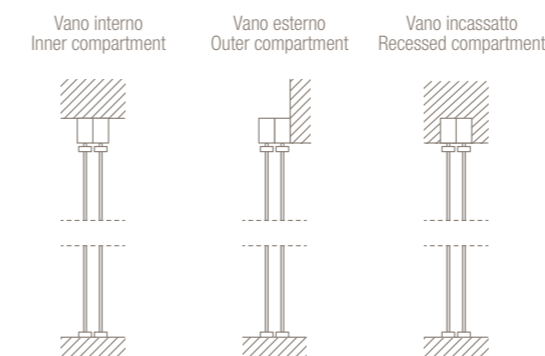
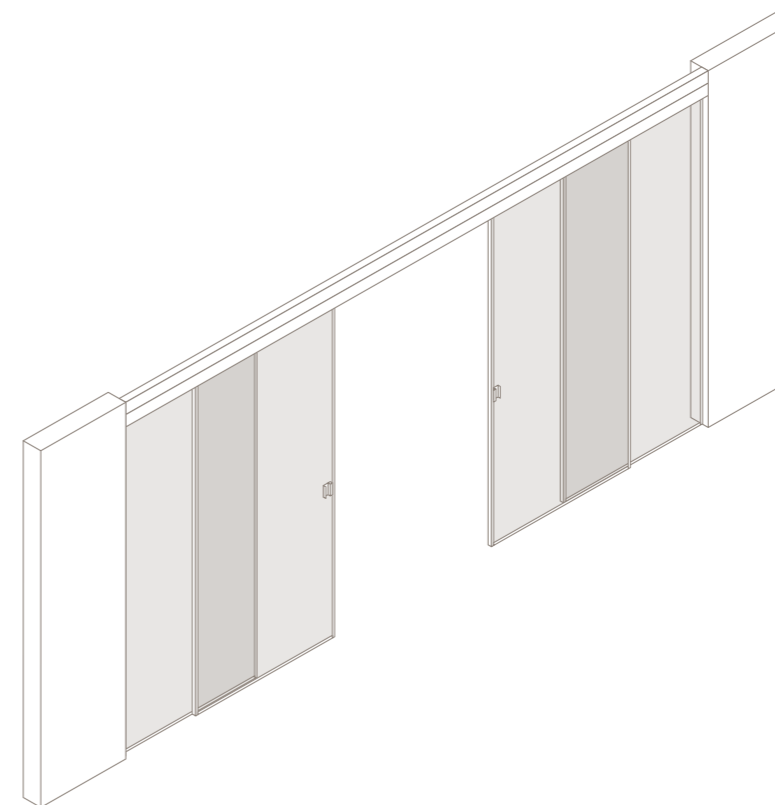

Sistema di pannelli scorrevoli o fissi a parete per dividere due ambienti o per chiudere locali cabina armadio. Il sistema è composto da binari guida in alluminio a uno o due vie fissati a soffitto a vista o a incasso in un controsoffitto, su cui sono ancorati i pannelli fissi o scorrevoli. Sopra i binari viene fissato un carter in finitura alluminio. La misura massima in altezza ottenibile è di 3000mm compreso di binario e 1300mm in larghezza. In corrispondenza dell'apertura dell'anta è applicata la maniglia, sia all'esterno che all'interno, nella stessa finitura del telaio.

A system of sliding or wall-mounted panels to separate two rooms or to close in the spaces of a walk-in wardrobe. The system is made up of one or two-way aluminium tracks mounted on the ceiling or recessed into a false ceiling, on which the fixed or sliding panels are mounted. A guard in aluminium finish is fixed to cover the tracks. The maximum height obtainable is 3000mm, including the track, and 1300mm in width. The handle is applied in correspondence with the door opening, on both the exterior and the interior, in the same finish as the frame.

Angoli interni _ *Inside corners***Descrizione**

In queste pagine viene mostrato l'utilizzo di Palo Alto Wall con angolo interno.
Nelle pagine successive vengono descritte e approfondite per tutti i sistemi notte questa soluzione progettuale.

Description

These pages show the use of Palo Alto Wall with internal angle.
In the following pages are described and explored these design solutions.

PALO ALTO I-BOX

ANGOLO INTERNO SENZA ANTE _ INSIDE CORNER WITHOUT DOORS

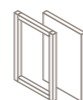

PALO ALTO I-BOX
Soluzione disponibile per _ Solution available for:
SPALLE TELAIO _ SIDE FRAME
SPALLE LEGNO _ WOOD SIDE

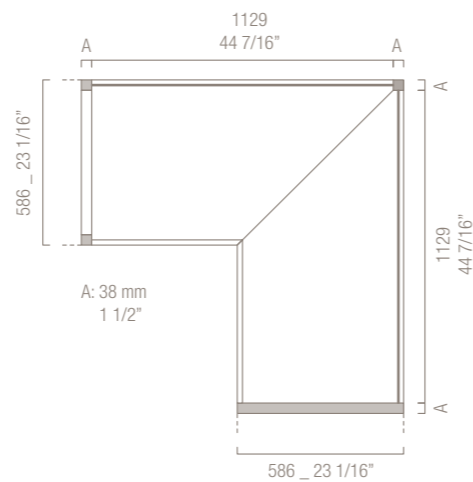
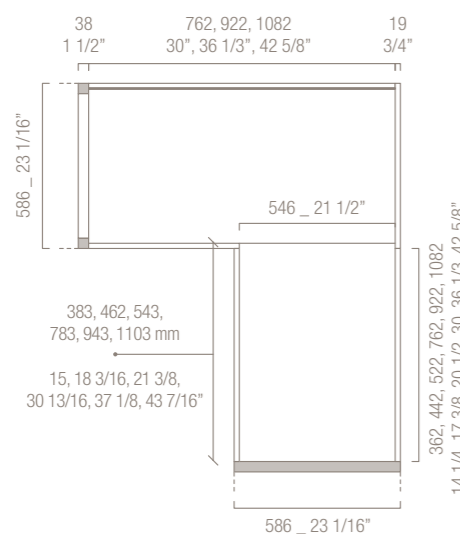
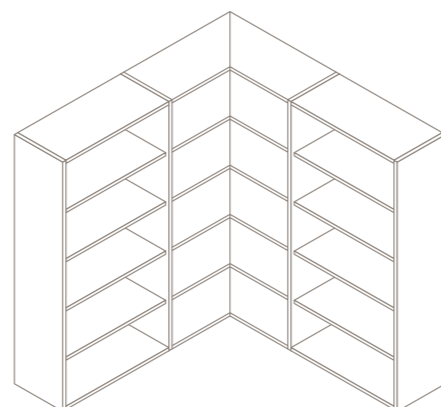
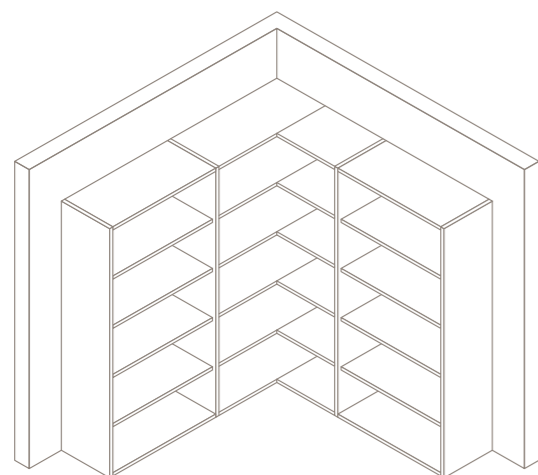

Con schienali legno, legno e vetro o legno e tecnomarble

Modulo ad angolo con dimensioni variabili. Costituito da uno schienale obbligatorio (pannello di giunzione) in legno Sp. 19 mm e uno schienale che può essere in legno Sp. 8 mm, in vetro Sp. 4 mm o tecnomarble Sp. 6 mm.

With wooden, wooden/glass or wooden / tecnomarble back panels

A corner module with different dimensions characterized by a compulsory wooden back panel Th. 6/8" and a back panel: Th. 3/8" wood-/Th. 1/8" glass/Th. 2/8" tecnomarble.

Con schienali vetro o tecnomarble

Modulo ad angolo a telaio con dimensioni fisse e taglio a 45° su coperchio, basamento e ripiano. Questo modulo consente di avere entrambi gli schienali dell'angolo in vetro o in tecnomarble.

With glass or tecnomarble back panels

A frame corner module with fixed dimensions and a 45°cut on the top, base and shelf. Through this module it is possible to have both corner back panels, glass or tecnomarble finish.

PALO ALTO I-BOX

ANGOLO INTERNO CON ANTE _ INSIDE CORNER WITH DOORS



Soluzione I-Box disponibile per _
I-Box solution available for:
SPALLE LEGNO _ WOOD SIDE

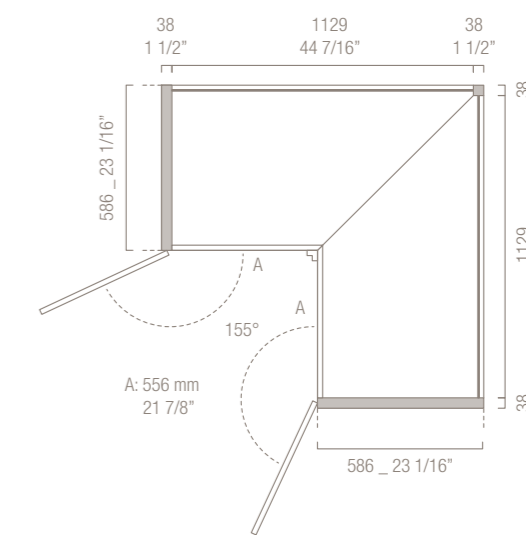
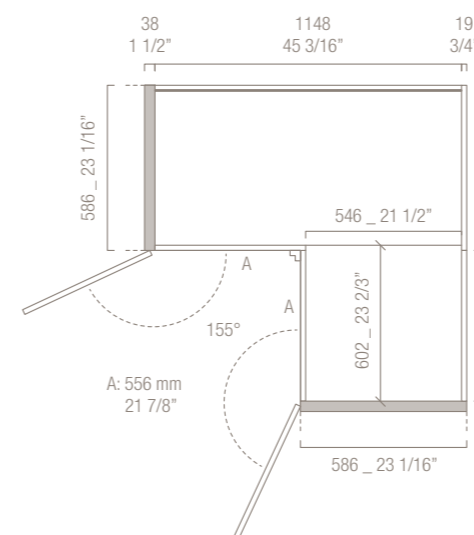
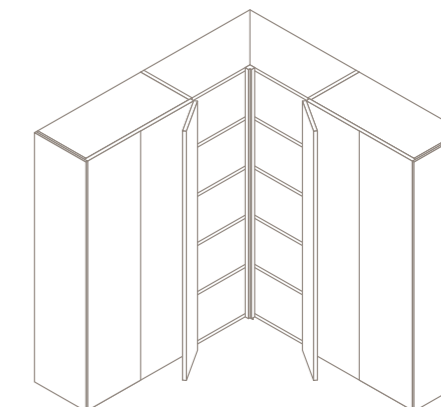
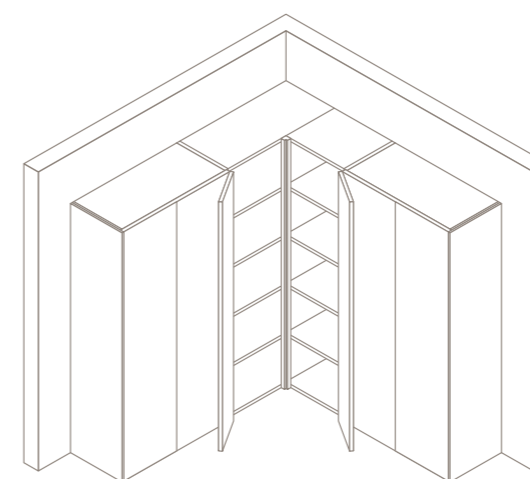

Con schienali legno, legno e vetro o legno e tecnomarble

Modulo ad angolo con dimensioni fisse; Ante Sp. 22 mm con apertura 155° (Escluse ante Narcisse, Zeus e Rex). Costituito da uno schienale obbligatorio (pannello di giunzione) in legno Sp. 19 mm e uno schienale che può essere in legno Sp. 8 mm, in vetro Sp. 4 mm o tecnomarble Sp. 6 mm. Non è possibile realizzare questa soluzione con spalle telaio, poiché la cerniera standard delle ante Sp. 22 mm per le spalle telaio non prevede l'apertura 155°.

With wooden, wooden/glass or wooden/techno-marble back panels

A wooden corner module with fixed dimensions and doors Th. 7/8" with a 155°opening (Except Narcisse, Zeus and Rex doors). Supplied with a wooden fixed part Th. 6/8" and a different part, for instance a wooden version Th. 3/8" , or Th. 1/8" , or Th.2/8" techno-marble. The side combining with the wooden back panel Th. 6/8" must compulsory be a wooden side.

Con schienali vetro o tecnomarble

Modulo ad angolo a telaio con dimensioni fisse e taglio a 45° su coperchio, basamento e ripiano. Questo modulo consente di avere entrambi gli schienali dell'angolo in vetro o in tecnomarble. Ante Sp. 22 mm e apertura 155° (escluse ante Narcisse, Zeus e Rex). Non è possibile realizzare questa soluzione con spalle telaio, poiché la cerniera standard delle ante Sp. 22 mm per le spalle telaio non prevede l'apertura 155°.

With glass or techno-marble back panels

A frame corner module with fixed dimensions and a 45°cut on the top, base and shelf. Through this module it is possible to have both glass back panels or techno-marble ones. Doors Th. 7/8" and 155° opening (apart from Narcisse, Zeus and Rex). It is not possible to provide this solution with frame sides, as the door standard zip Th. 7/8" for the frame sides does not include a 155°opening.

PALO ALTO I-BOX**ANGOLO INTERNO PER ANTE NARCISSE E ZEUS _ INSIDE CORNER FOR NARCISSE AND ZEUS DOORS**

Soluzione I-Box disponibile per _
I-Box solution available for:
SPALLE TELAIO _ SIDE FRAME
SPALLE LEGNO _ WOOD SIDE

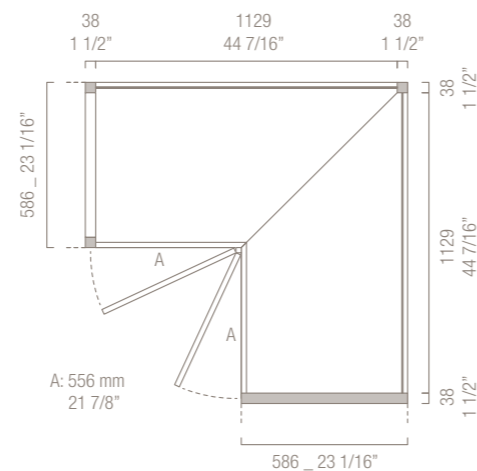
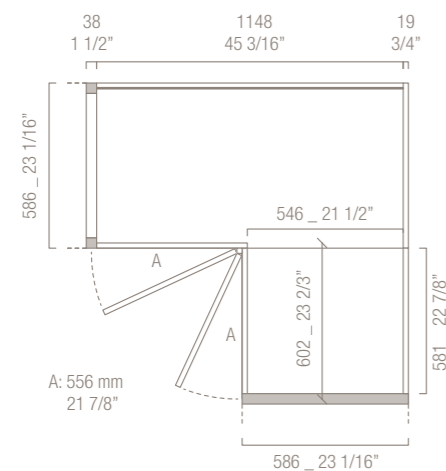
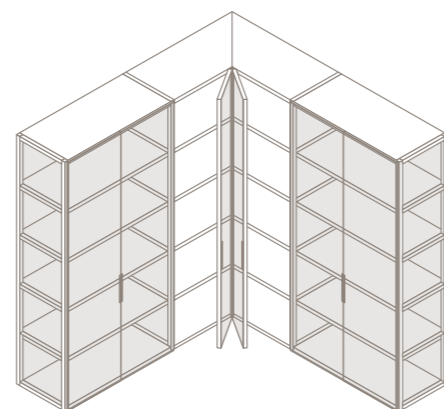
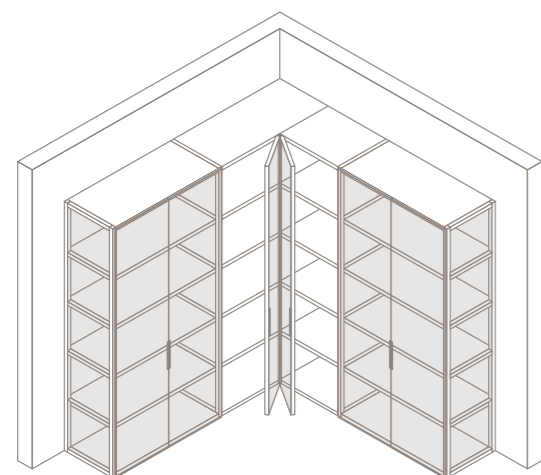
**Con schienali legno, legno e vetro o legno e tecnomarble**

Modulo ad angolo con dimensioni fisse; Ante Narcisse, Zeus Sp. 28 mm con apertura 98°. Costituito da uno schienale obbligatorio (pannello di giunzione) in legno Sp. 19 mm e uno schienale che può essere in legno Sp. 8 mm, in vetro Sp. 4 mm o tecnomarble Sp. 6 mm. L'angolo è dotato di un pilastrino centrale e le ante sono incernierate all'interno dell'angolo, con l'apertura come da disegno.

With wooden, wooden/glass or wooden / technomarle back panels

A corner module with fixed dimensions; Narcisse and Zeus doors Th. 1 1/8" with a 98° opening. Supplied with a compulsory wooden back panel Th. 6/8" and a back panel: Th. 3/8" wood-/Th. 1/8" glass/Th. 2/8" technomarle. The corner is equipped with a small central pillar. The doors are zipped inside the corner with an opening as shown in the drawing.

Con schienali vetro o tecnomarble

Modulo ad angolo a telaio con dimensioni fisse e taglio a 45° su coperchio, basamento e ripiano. Questo modulo consente di avere entrambi gli schienali dell'angolo in vetro o in tecnomarble. Anta Narcisse, Zeus Sp. 28 mm con apertura 98°. L'angolo è dotato di un pilastrino centrale e le ante sono incernierate all'interno dell'angolo, con l'apertura come da disegno.

With glass or technomarle back panels

A frame corner module with fixed dimensions and a 45° cut on the top, base and shelf. Through this module it is possible to have both glass back panels or technomarle ones. Narcisse and Zeus doors Th. 1 1/8" with a 98° opening. The corner is equipped with a small central pillar. The doors are zipped inside the corner with an opening as shown in the drawing.

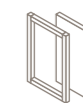
PALO ALTO I-BOX**ANGOLO INTERNO PER ANTE REX _ INSIDE CORNER FOR REX DOORS**

Soluzione I-Box disponibile per _
I-Box solution available for:
SPALLE TELAIO _ SIDE FRAME
SPALLE LEGNO _ WOOD SIDE

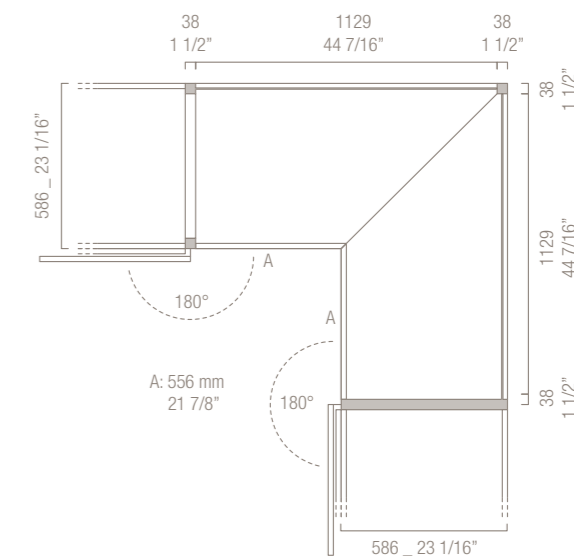
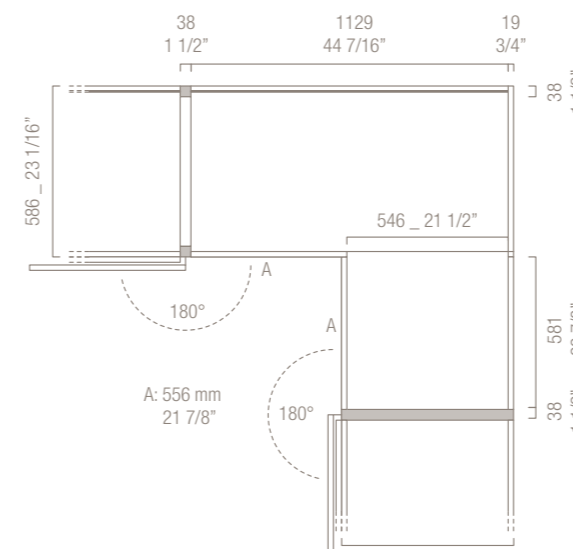
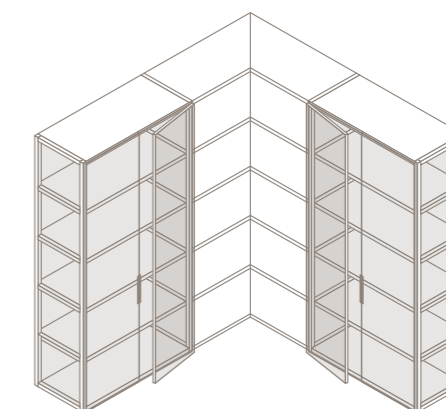
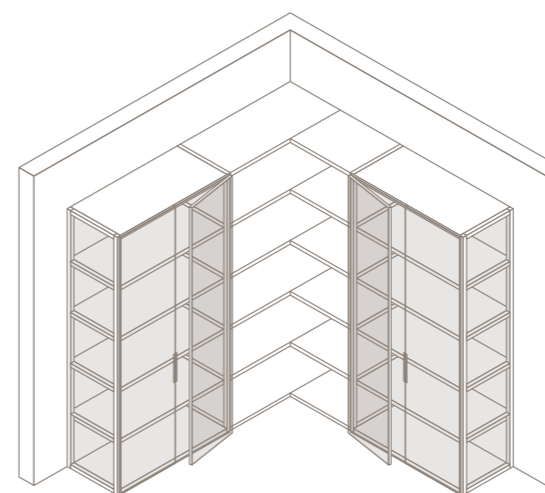
**Con schienali legno, legno e vetro o legno e tecnomarble**

Modulo ad angolo con dimensioni fisse; Anta Rex Sp. 39 mm con apertura 180°. Costituito da uno schienale obbligatorio (pannello di giunzione) in legno Sp. 19 mm e uno schienale che può essere in legno Sp. 8 mm, in vetro Sp. 4 mm o tecnomarble Sp. 6 mm.

With wooden, wooden/glass or wooden/technomarle back panels

A corner module with fixed dimensions. Rex door Th. 1 1/8" with a 180° opening. Supplied with a compulsory wooden back panel Th. 6/8" and a back panel: Th. 3/8" wood-/Th. 1/8" glass/Th. 2/8" technomarle.

Con schienali vetro o tecnomarble

Modulo ad angolo a telaio con dimensioni fisse e taglio a 45° su coperchio, basamento e ripiano. Questo modulo consente di avere entrambi gli schienali dell'angolo in vetro o in tecnomarble. Anta Rex Sp. 39 mm con apertura 180°.

With glass or technomarle back panels

A frame corner module with fixed dimensions and a 45° cut on the top, base and shelf. Through this module it is possible to have both glass back panels or technomarle ones. Rex door Th. 1 1/2" with a 180° opening.

PALO ALTO I-BOX
ANGOLO RX6 _ RX6 CORNER



Soluzione I-Box disponibile per _
I-Box solution available for:
SPALLE TELAIO _ SIDE FRAME
SPALLE LEGNO _ WOOD SIDE

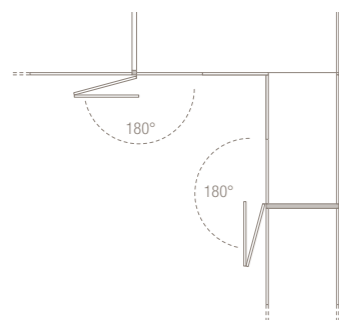
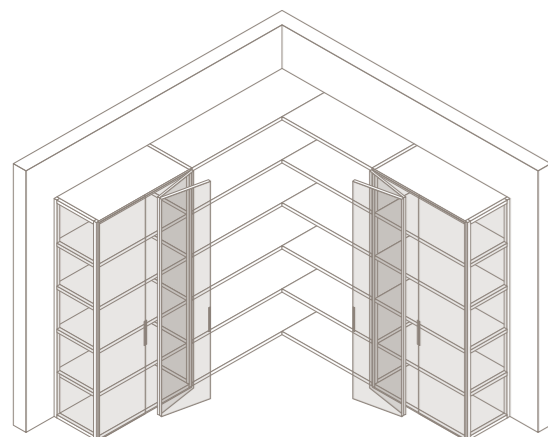

Soluzione ad angolo con apertura RX6. È ottenuta mediante l'utilizzo di un'anta fissa alla quale viene affiancato la spalla di un altro sistema con qualunque tipologia di apertura. Questa soluzione non è realizzabile con spalle telaio.

A corner solution among the hinged door opening typology and other opening systems. Resulted from the use of a fixed door and a filler to which the side of another system of any opening typology is linked. It is not possible to provide this solution with frame sides.

PALO ALTO I-BOX
ANGOLO NON USUFRUIBILE _ NON-USABLE CORNER



Soluzione I-Box disponibile per _
I-Box solution available for:
SPALLE TELAIO _ SIDE FRAME
SPALLE LEGNO _ WOOD SIDE

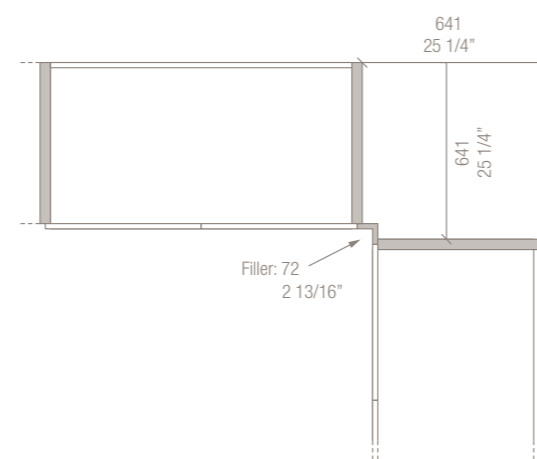
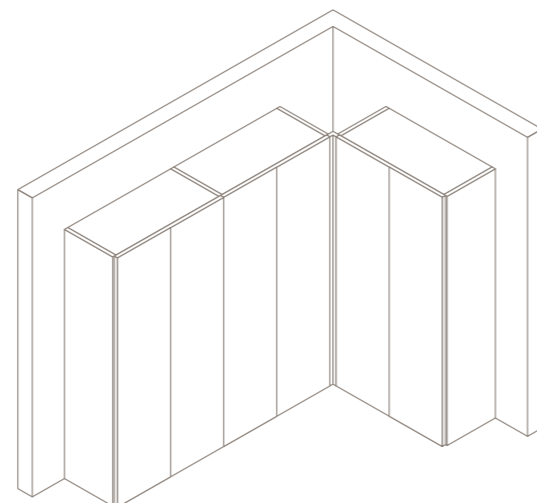

Modulo con due spalle legno centrali oppure con due spalle telaio centrali con vetro e senza vetro. Attrezzabili con ripiani interni. Si collega indifferentemente a moduli con qualsiasi tipo di apertura. Riducibile solo in altezza.

Module with two central wooden sides or two central wooden central sides with or without glass. Available with internal shelves. This system is interchangeably connected to the modules with any opening typologies. Only height reduction.

PALO ALTO I-BOX
ANGOLO TRA APERTURA BATTENTE E ALTRE TIPOLOGIE _
CORNER SOLUTION AMONG THE HINGED DOOR TYPOLOGY
AND OTHER OPENING TYPOLOGIES



Soluzione I-Box disponibile per _
I-Box solution available for:
SPALLE LEGNO _ WOOD SIDE

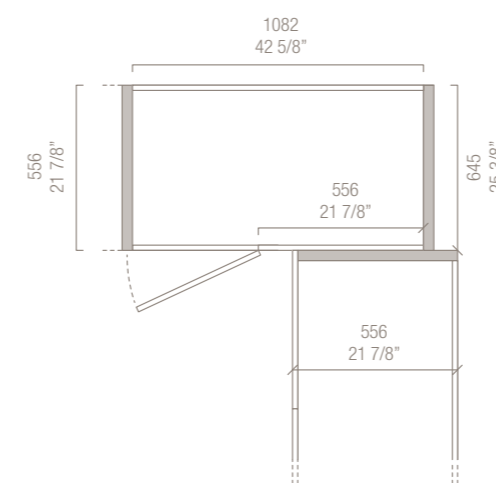
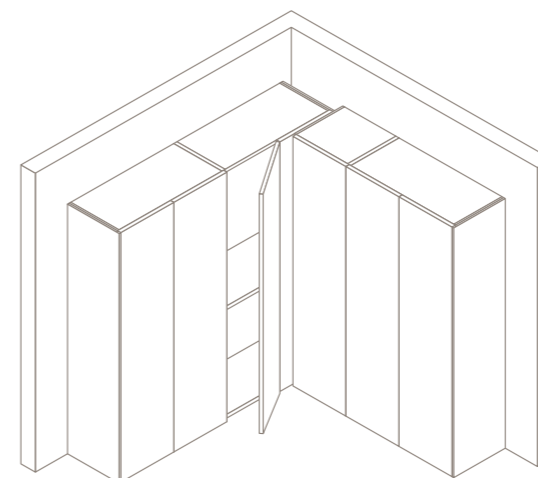

Soluzione ad angolo tra sistema a tipologia di apertura battente e sistemi con altre tipologie di apertura. È ottenuta mediante l'utilizzo di un'anta fissa alla quale viene affiancato la spalla di un altro sistema con qualunque tipologia di apertura. Questa soluzione non è realizzabile con spalle telaio.

A corner solution among the hinged door opening typology and other opening systems. Resulted from the use of a fixed door and a filler to which the side of another system of any opening typology is linked. It is not possible to provide this solution with frame sides.

PALO ALTO I-BOX
ANGOLO TRA APERTURA SCORREVOLE E ALTRE TIPOLOGIE _
CORNER SOLUTION AMONG THE SLIDING DOOR TYPOLOGY
AND OTHER OPENING TYPOLOGIES



Soluzione I-Box disponibile per _
I-Box solution available for:
SPALLE LEGNO _ WOOD SIDE

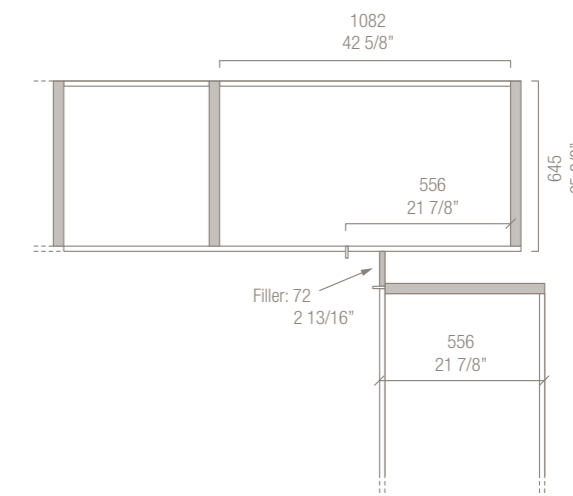
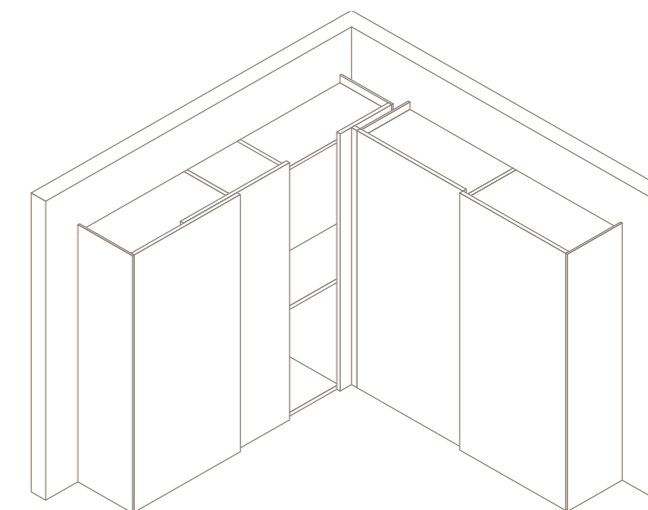

Soluzione ad angolo tra sistema a tipologia di apertura scorrevole e sistemi con altre tipologie di apertura. È ottenuta mediante l'utilizzo di un'anta fissa e di un tamponamento al quale viene affiancato la spalla di un altro sistema con qualunque tipologia di apertura. Questa soluzione non è realizzabile con spalle telaio.

A corner solution between a sliding opening typology and other opening systems. Resulted from the use of a fixed door and a filler to which the side of another system of any opening typology is linked. It is not possible to provide this solution with frame sides.

PALO ALTO WALL
ANGOLO ESTERNO _ NON-USABLE CORNER

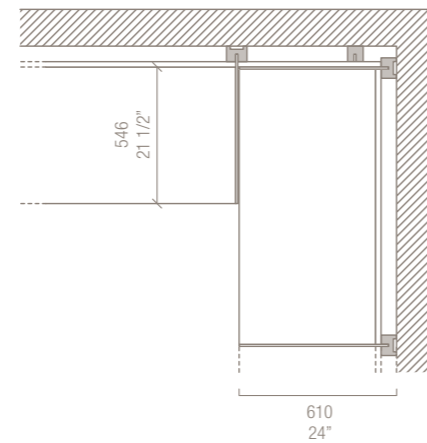
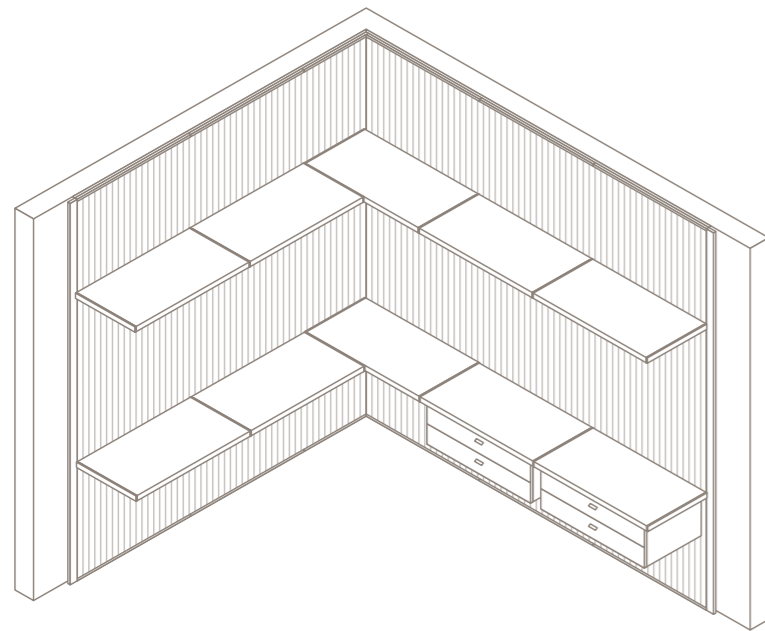

Modulo ad angolo con dimensioni variabili. Completamente attrezzabile con accessori quali ripiani, cassettiere o illuminazione led. Modulo costituito da pannelli Sp. 22 mm sorretti dai montanti fissati a muro.

Corner module with variable dimensions. Fully equipable with accessories such as shelves and chests of drawers or led lighting. Consisting of 22 mm thick panels supported by the uprights fixed to the wall.

PALO ALTO FREE
ANGOLO INTERNO _ INSIDE CORNER

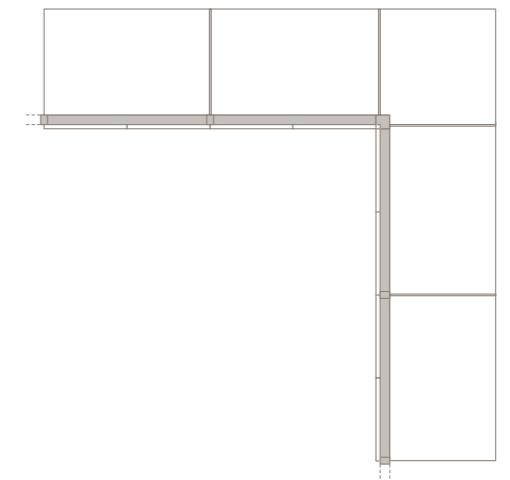
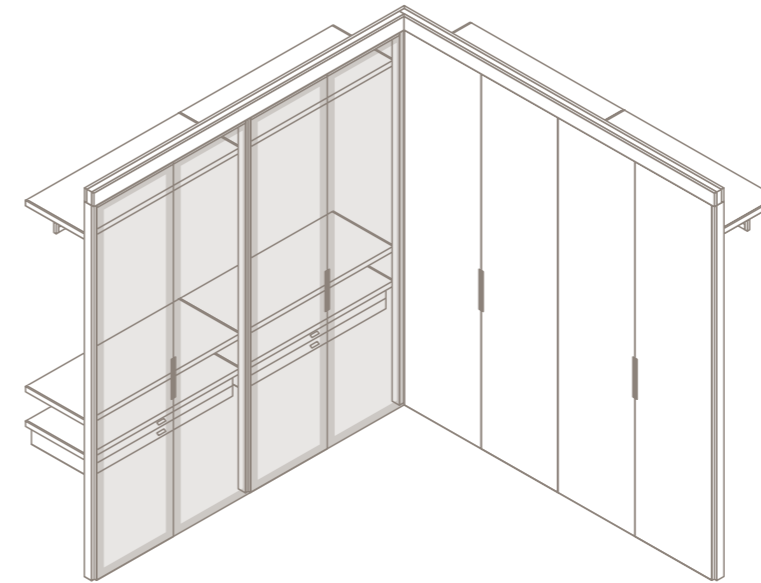

Soluzione ad angolo interno per sistema notte Palo Alto Free ottenuta dall'intersezione di due composizioni lineari, tamponamenti di congiunzione dedicati e ripiano ad angolo.

Internal corner solution for Palo Alto Free night system obtained from the intersection of two linear compositions, dedicated joining fillers and corner shelf.

Vanity, vani a giorno e contenitori _ *Vanity, open compartments and storage units***Descrizione**

In queste pagine viene mostrato il modulo Vanity e il modulo TV per il sistema Palo Alto I-Box.
Nelle pagine successive vengono descritte e approfondite per tutti i sistemi notte tutte le varianti di questa soluzione progettuale.

Description

These pages show the Vanity module and the TV module for the Palo Alto I-Box system.
In the following pages all variants of this design solution are described and explored for all night systems.

PALO ALTO I-BOX
VANITY _ VANITY



Soluzione I-Box disponibile per _
 I-Box solution available for:
SPALLE LEGNO _ WOOD SIDE

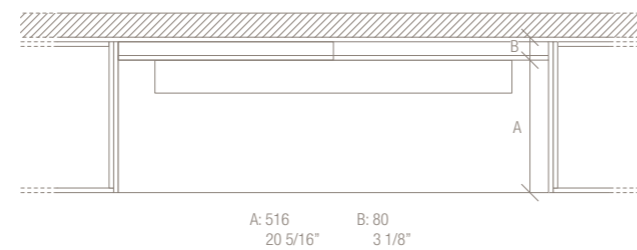
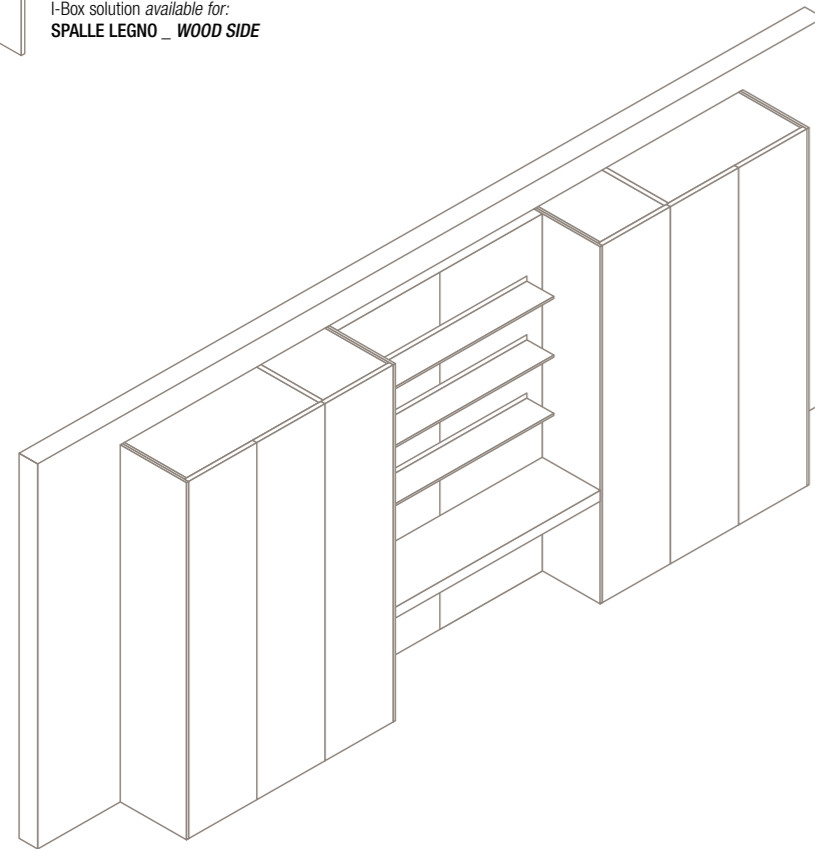

Soluzione realizzata attraverso l'utilizzo di una pannellatura Sp. 80 mm e uno scrittoio pensile Sp. 80 mm, posizionati tra due armadi con sovraspalla. Lo scrittoio è attrezzabile con dei cassetti ed è consigliato posizionarlo ad H. 735 mm da terra a bordo superiore dello scrittoio. È possibile attrezzare la pannellatura con mensole con luce LED ZAFFIRO.

Solution obtained through the use of a Th. 3 1/8" panelling and a Th. 3 1/8" filler desk placed between two wardrobes with an over-side element. The desk is supplying with a few drawers. Suitable to be placed at a H. 28 7/8" on the upper edge of the desk. It is possible to set the panelling with shelves supplied with a LED ZAFFIRO light.

PALO ALTO WALL
VANITY _ VANITY

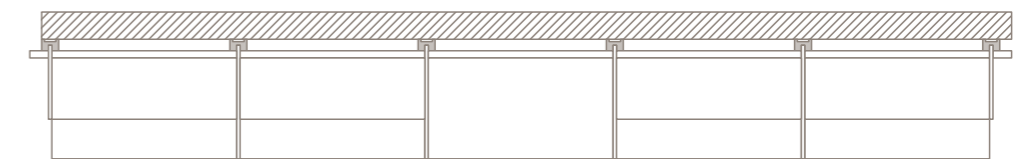
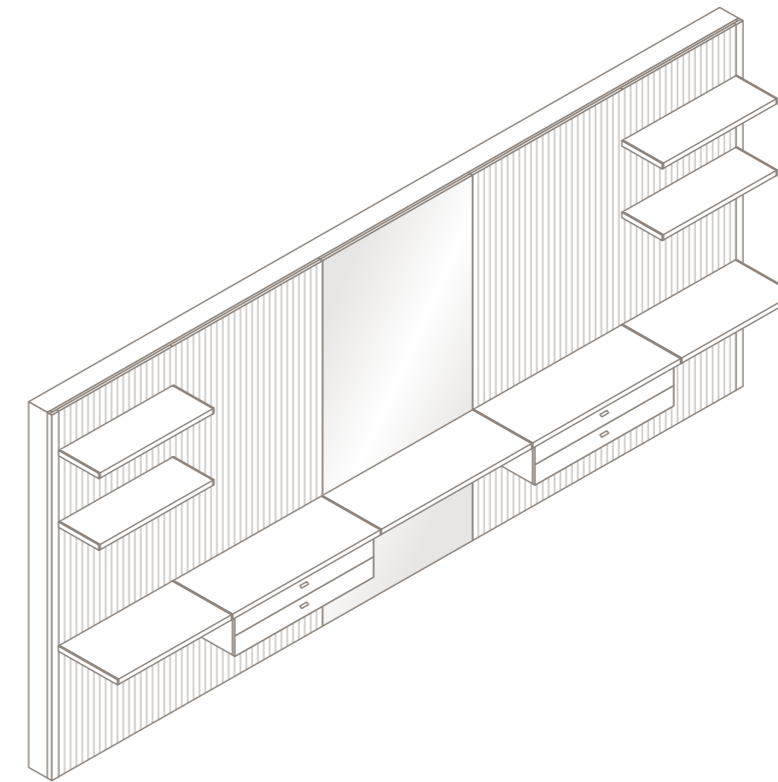

Modulo boiserie lineare utilizzabile come scrittoio tramite l'uso di ripiani posizionati in linea sulla stessa altezza, attrezzabile grazie all'implementazione di cassettiere sospese e caratterizzabile con il cambio di finitura della pannellatura con vetro a specchio in prossimità dello scrittoio.

Linear boiserie module which can be used as a writing desk through the use of shelves placed in line on the same height, it can be equipped through the implementation of suspended drawer units and can further be characterized by changing the finish of the panelling with mirrored glass near the desk.

PALO ALTO I-BOX**VANO A GIORNO _ OPEN SPACE**

Soluzione I-Box disponibile per _
I-Box solution available for:
SPALLE LEGNO _ WOOD SIDE

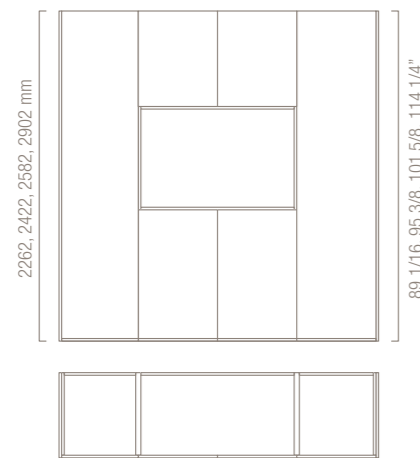
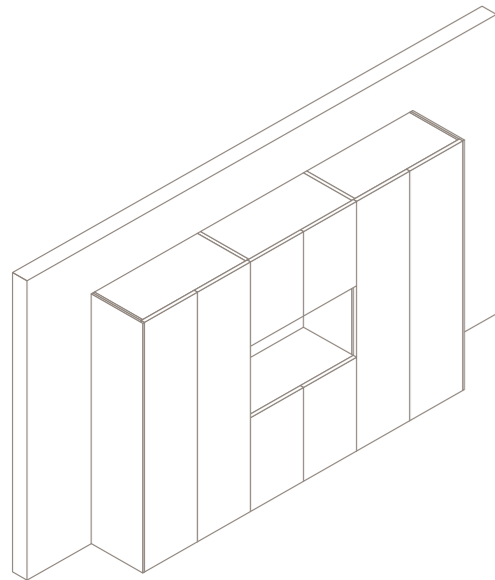
**Soluzione vano a giorno**

È possibile attrezzare il vano a giorno con uno specchio di fondo.

Questa soluzione non è realizzabile con spalle telaio.

Dimensioni: H 916 mm, H 1076 mm - L 922 mm, L 1082 mm, L 1242 mm.

Open space solution

It is possible to supply the open space with a mirror at the background.

This solution can not be provided through frame sides.

Dimensions: H. 36 1/8", H. 42 3/8" - L. 36 2/8", L. 42 5/8", L. 48 7/8".

PALO ALTO I-BOX**VANO A GIORNO PER TV_ TV SET OPEN SPACE**

Soluzione I-Box disponibile per _
I-Box solution available for:
SPALLE LEGNO _ WOOD SIDE

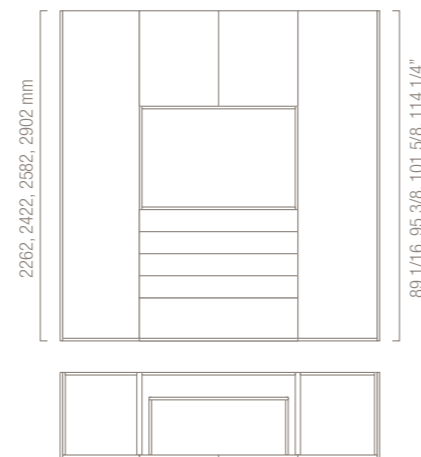
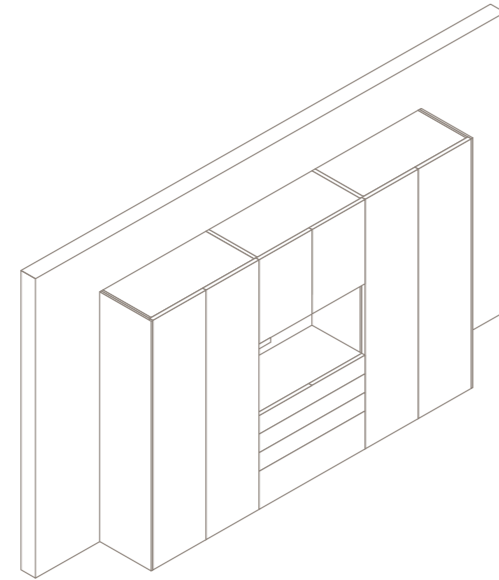
**Soluzione Vano TV**

Il vano TV è ottenuto con uno schienale avanzato.

Questa soluzione non è realizzabile con spalle telaio.

Dimensioni: H 916 mm, H 1076 mm - L 922 mm, L 1082 mm, L 1242 mm.

TV Set Space

The TV Set Space is provided through an advanced back panel.

Dimensions: H. 36 1/8", H. 42 3/8" - L. 36 2/8", L. 42 5/8", L. 48 7/8".

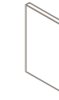
PALO ALTO I-BOX**VANO A GIORNO CON CONTENITORE MAGGIE _ OPEN SPACE WITH MAGGIE CASE**

Soluzione I-Box disponibile per _
I-Box solution available for:
SPALLE LEGNO _ WOOD SIDE

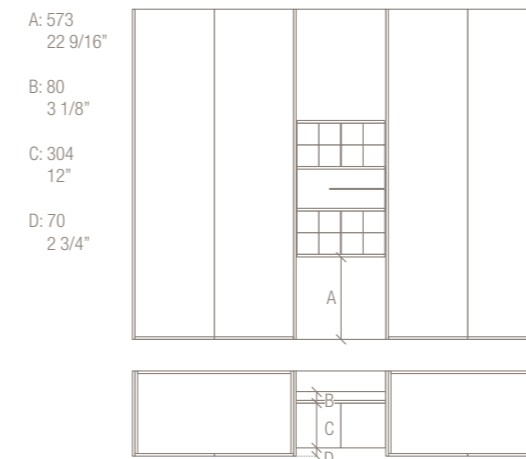
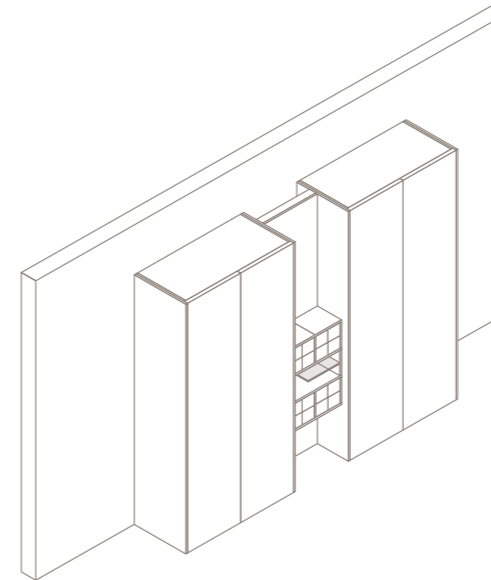

Soluzione realizzata attraverso l'utilizzo di una pannellatura Sp. 80 mm tra due armadi con sovraspalla e moduli giorno Maggie. Si collega indifferentemente a moduli con qualsiasi tipologia di apertura. Per un corretto posizionamento dei moduli a giorno Maggie si consiglia un posizionamento in altezza del primo modulo Maggie a 573 mm dal bordo inferiore della boiserie + 6 mm di piedino, mentre in profondità si consiglia un posizionamento a 70 mm dal bordo anteriore della sovraspalla. Questa soluzione non è realizzabile con spalle telaio.

Solution obtained through the use of a Th. 3 1/8" paneling between two wardrobes with finishing side panel and Maggie day modules. It connects indifferently to modules with any type of opening. For a correct positioning of the Maggie open modules, it is advisable to position the first module at a H. 18 7/8" from the wire below the structure, while at depth we recommend a 2 6/8" positioning at the external edge of the finishing side panel. The first item Maggie.

Raccordi e integrazioni _ *Fittings and integrations***Descrizione**

In queste pagine viene mostrato l'integrazione tra Palo Alto Wall e Palo Alto I-Box.
Nelle pagine successive vengono descritte e approfondite per tutti i sistemi notte questa soluzione progettuale.

Description

These pages show the integration between Palo Alto Wall and Palo Alto I-Box.
In the following pages are described and explored these design solutions.

PALO ALTO I-BOX & WALL

INTEGRAZIONE I-BOX & WALL _ I-BOX & WALL INTEGRATION

PALO ALTO I-BOX

BOWINDOW

Soluzione I-Box disponibile per _
I-Box solution available for:
SPALLE LEGNO _ WOOD SIDE

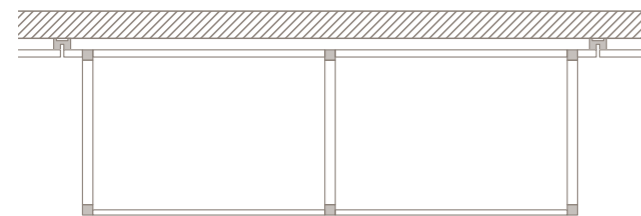
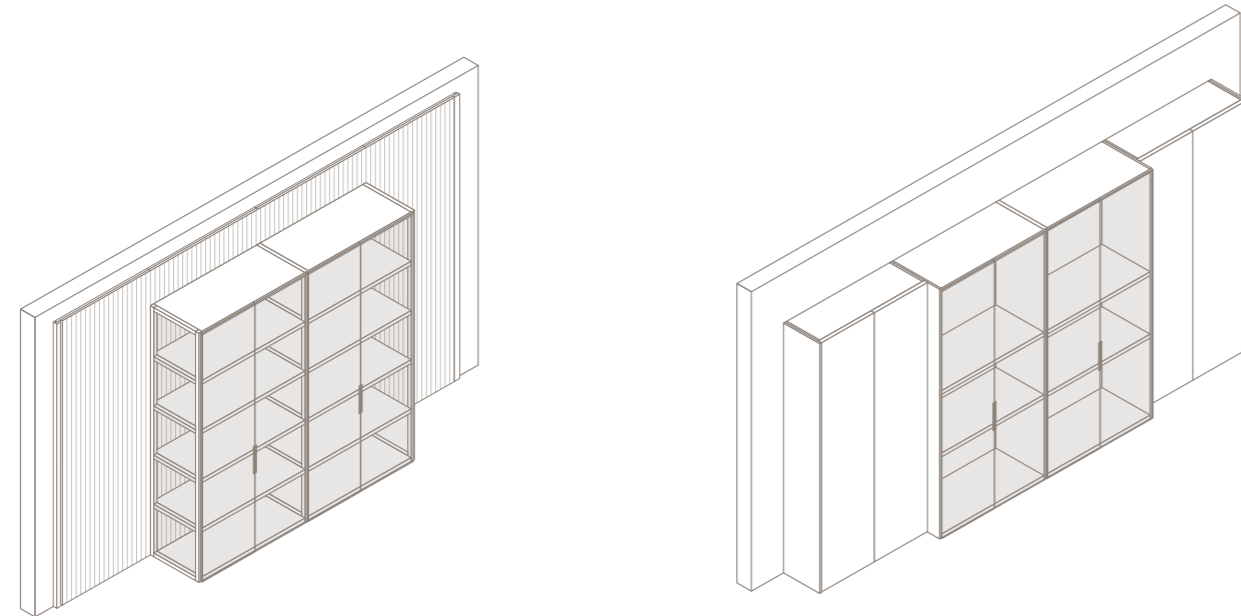

Soluzione di integrazione tra Palo Alto I-Box e Wall dove è possibile applicare allo schienale dell'armadiatura I-Box la stessa finitura della pannellatura Wall che circondando l'armadio permette di mantenere la totale continuità visiva su tutta la parete.

Integration solution between "Palo Alto I-Box" and "Wall", it is possible to apply as back panel of "I-Box" the same finish as the "Wall" paneling, that while also surrounding the cabinet allows for total visual continuity across the entire space.

Soluzione ottenuta affiancando strutture di P. 380 mm con strutture di P. 586 mm oppure affiancando strutture di differenti profondità su misura. Il cambio di profondità non è realizzabile con una spalla telaio.

This solution is obtained while setting D. 15" depth structures to Th. 23 1/8" ones or complementing structures with different tailored depth. The depth modification is not possible through a frame side.

PALO ALTO I-BOX

MODULO SMUSSO _ SOFTEN MODULE

Soluzione I-Box disponibile per _
I-Box solution available for:
SPALLE LEGNO _ WOOD SIDE

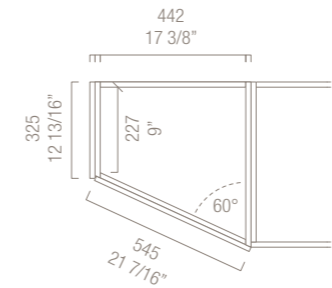
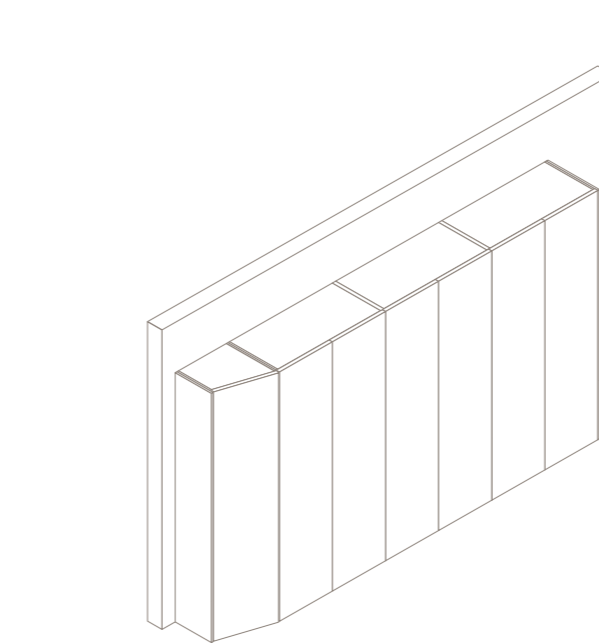

Modulo realizzato con una spalla P. 586 mm, una spalla terminale smusso P. 320 mm, un ripiano smussato a 60° e un'anta inclinata. Attrezzabile con sovraspalla di finitura P. 325 mm. Soluzione utilizzata come elemento terminale meno ingombrante. Questa soluzione non è realizzabile con spalle telaio, tipologie di aperture scorrevoli e coplanari. Nelle soluzioni con tipologie di aperture battenti non è possibile utilizzare le ante: Narcisse, Zeus, Rex

Module obtained with one side (D. 23 1/8"), a side of a D. 12 5/8" soften terminal, a 60° soften shelf and a sloped door. Setting with a D. 12 6/8" finishing. This solution is used as a less bulky terminal element. This solution can not be provided through frame sides, sliding and coplanar opening typologies. As far as the solutions with hinged door opening typologies are concerned, it is not possible to use the following doors: Narcisse, Zeus and Rex.

PALO ALTO I-BOX

TERMINALE E RACCORDO _ TERMINAL AND CONNECTION

Soluzione I-Box disponibile per _
I-Box solution available for:
SPALLE LEGNO _ WOOD SIDE

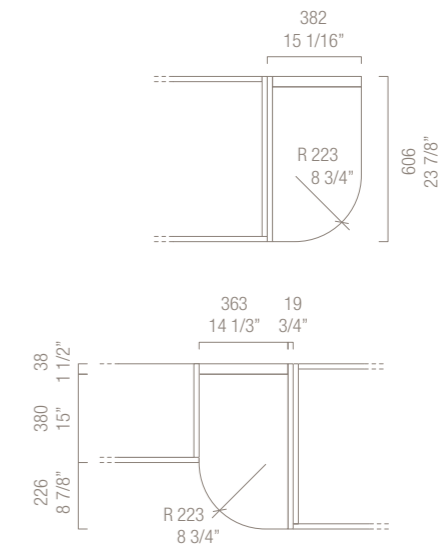
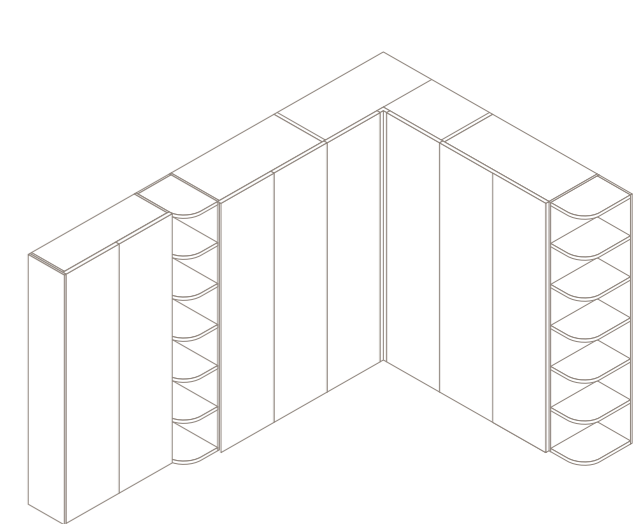

Questi elementi vengono utilizzati come terminali affiancati a un armadio di P. 586 mm, oppure come elementi di raccordo tra un armadio di P. 586 mm e un armadio di P. 380 mm o una libreria Crossing sempre di P. 380 mm.

These elements are used as terminals linked to a wardrobe or as connecting elements between a D. 15" or a Crossing bookcase (always amounting to D. 15").

Ponti, sopralzi e mansarde _ Bridges, overhangs attics**Descrizione**

In queste pagine viene mostrata l'integrazione tra Paolo Alto Wall e Palo Alto I-Box in una stanza mansardata e l'utilizzo di armadiature Palo Alto I-Box sospese e pannellature Palo Alto Wall.
Nelle pagine successive vengono descritte e approfondite per tutti i sistemi notte questa soluzione progettuale.

Description

These pages show the integration of Paolo Alto Wall and Palo Alto I-Box in an attic room and the use of Palo Alto I-Box hanging cabinets and Palo Alto Wall paneling.
In the following pages are described and explored these design solutions.

PALO ALTO I-BOX

**ARMADIO CON ANTE A MANSARDA _
WARDROBE WITH ATTIC DOORS**

Soluzione I-Box disponibile per _
I-Box solution available for:
SPALLE LEGNO _ WOOD SIDE

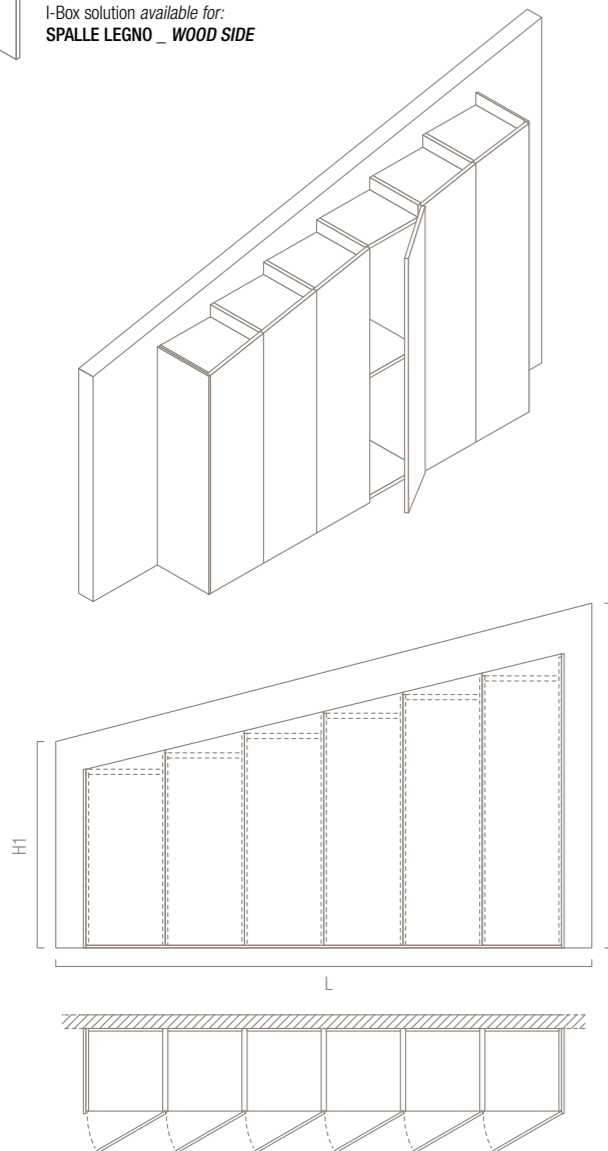

Soluzione ottenuta abbinando moduli di diversa altezza a scaletta e ante con taglio in diagonale. Per calcolare la diagonale esatta, comunicare all'azienda le dimensioni H1, H2, L. Questa soluzione non è realizzabile con spalle telaio, tipologie di aperture scorrevoli e complanari. Nelle soluzioni con tipologie di aperture battenti non è possibile utilizzare le ante: Narcisse, Zeus, Rex, London, Brillanta, First.

Solution obtained while setting up modules with different height and diagonal cut doors. In order to establish the right diagonal, pls inform the company about H1 and H2 dimensions. This solution can not be provided through frame sides, sliding and coplanar opening typologies. As far as the solutions with hinged door opening typologies are concerned, it is not possible to use the following doors: Narcisse, Zeus, Rex, Brillanta and First.

PALO ALTO WALL

BOISERIE A MANSARDA _ ATTIC BOISERIE

Soluzione I-Box disponibile per _
I-Box solution available for:
SPALLE LEGNO _ WOOD SIDE

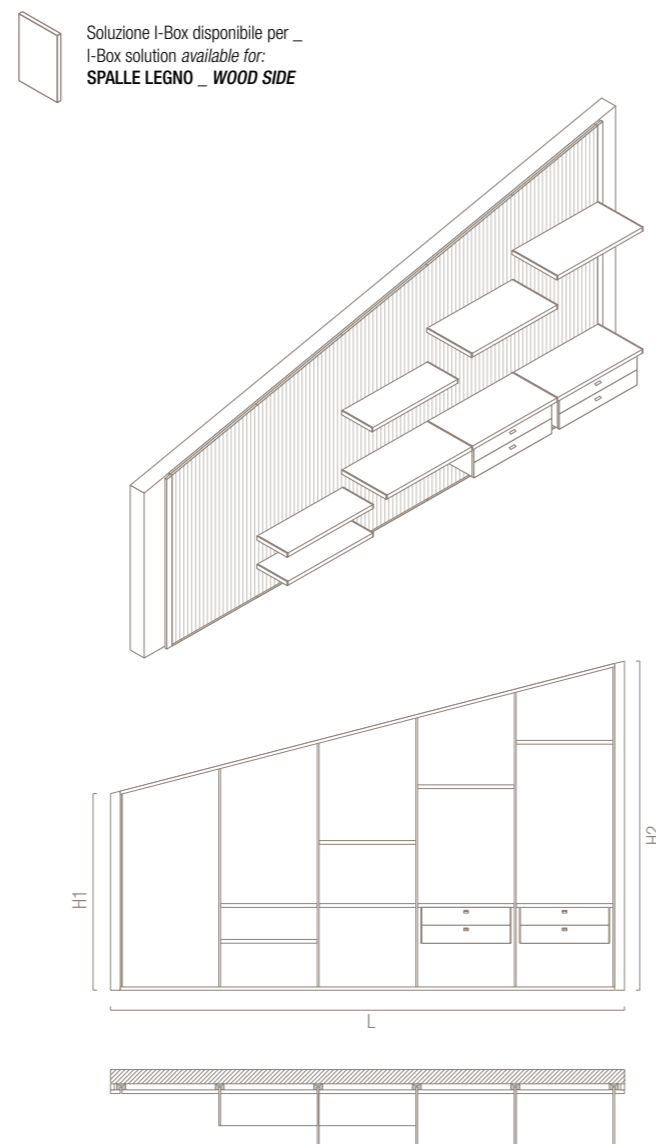

Soluzione ottenuta con taglio in diagonale dei pannelli. Per calcolare la diagonale esatta, comunicare all'azienda le dimensioni H1, H2, L.

Solution obtained by setting up a composition of diagonal cut panels. In order to establish the right diagonal, pls inform the company about H1 and H2 dimensions.

PALO ALTO I-BOX

SOPRALZO _ STAND

Soluzione I-Box disponibile per _
I-Box solution available for:
SPALLE LEGNO _ WOOD SIDE

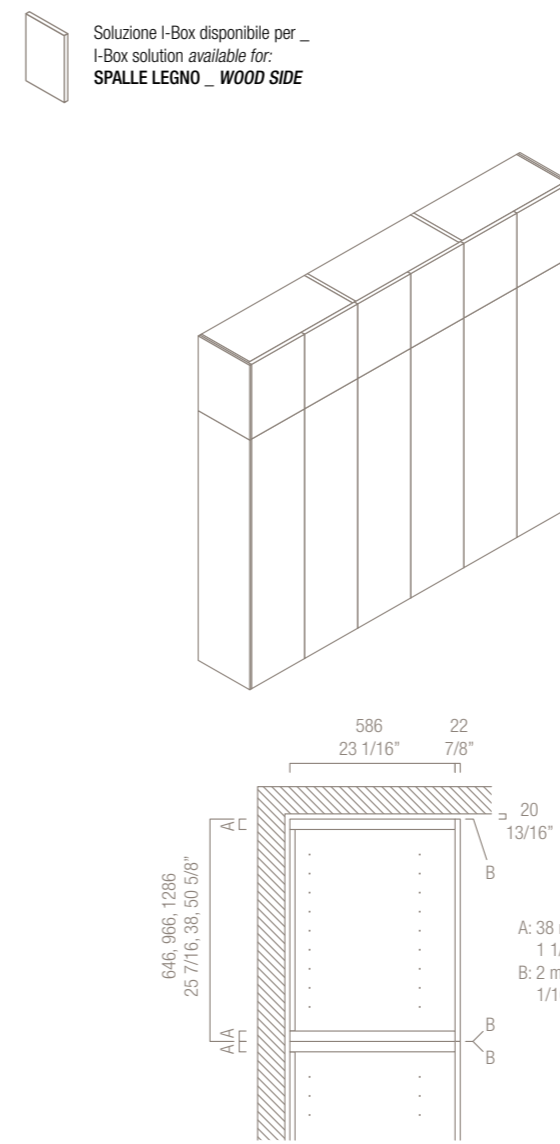

Soluzione per altezze superiori 2902 mm, ottenuta sovrapponendo due strutture. Questa soluzione non è realizzabile con spalle telaio, tipologie di aperture scorrevoli e complanari. Nelle soluzioni con tipologie di aperture battenti non è possibile utilizzare le ante: Narcisse, Zeus, Rex.

Solution for heights higher than 114 2/8" obtained overlapping the two structures. This solution is not possible with frame sides, with sliding and coplanar opening typologies. In the hinged door typologies, it is not possible to use the following doors: Narcisse, Zeus, Rex.

PALO ALTO I-BOX

PONTI SOSPESI _ HOOKED BRIDGE

Soluzione I-Box disponibile per _
I-Box solution available for:
SPALLE LEGNO _ WOOD SIDE

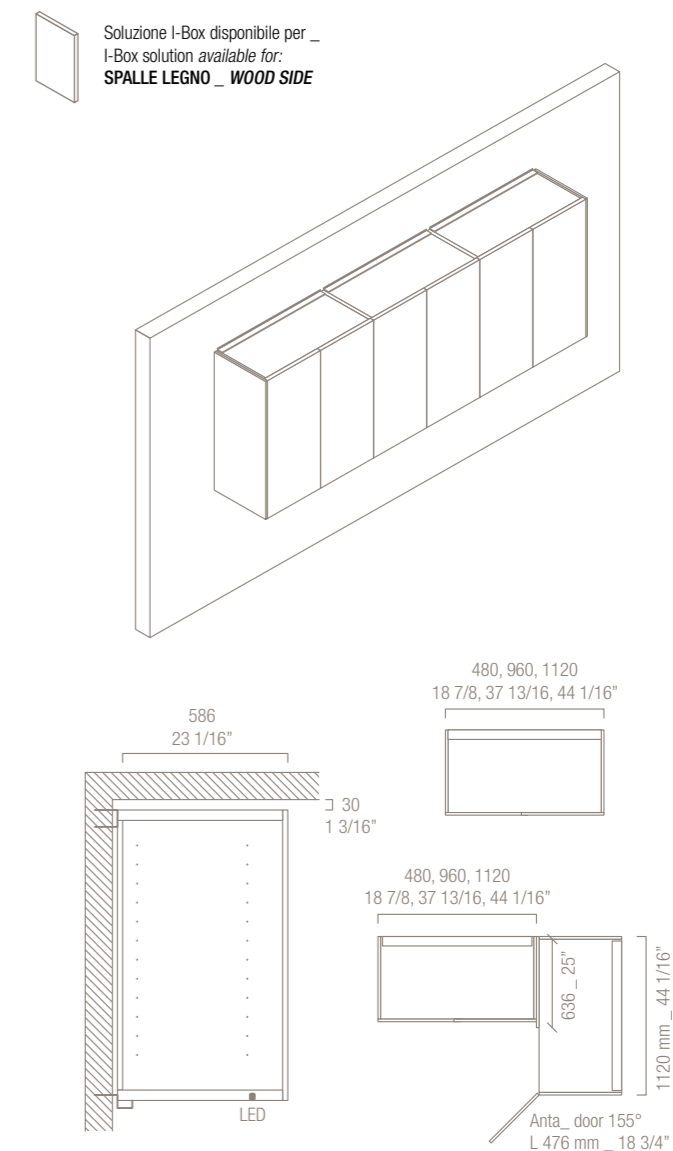

Sistema a contenitori affiancati e uniti tra loro in appoggio su una barra inferiore di portata e una barra superiore di tenuta trasversale realizzate in alluminio. I contenitori sono realizzati con base e coperchio rinforzati e dotati di un profilo superiore per l'aggancio alla barra superiore. La portata dei contenitori è di 80 kg. Questa soluzione non è realizzabile con spalle telaio, tipologie di aperture scorrevoli e complanari. Nelle soluzioni con tipologie di aperture battenti non è possibile utilizzare le ante: Narcisse, Zeus, Rex.

A system characterized by linked containers on a lower aluminum and an upper bar. The containers are provided by a reinforced base and top supplied with a higher profile as a link to the upper bar. The container capacity amounts to 80 Kg. This solution can not be provided with frame sides, sliding and coplanar opening typologies. As far as the solutions with hinged door opening typologies are concerned, it is not possible to use the following doors: Narcisse, Zeus, Rex.

Cabine _ *Walk-in closet***Descrizione**

In queste pagine viene mostrato l'integrazione tra Palo Alto Free ad angolo interno e Palo alto Wall ad angolo interno a formare cabine indipendenti. Nelle pagine successive vengono descritte e approfondite per tutti i sistemi notte questa soluzione progettuali simili.

Description

These pages show the integration of Palo Alto Free with external corner and Palo Alto Wall with internal corner to create walk-in closet. In the following pages are described and explored similar design solutions.

PALO ALTO FREE
ANGOLO ESTERNO RX6 _ EXTERNAL RX6 CORNER

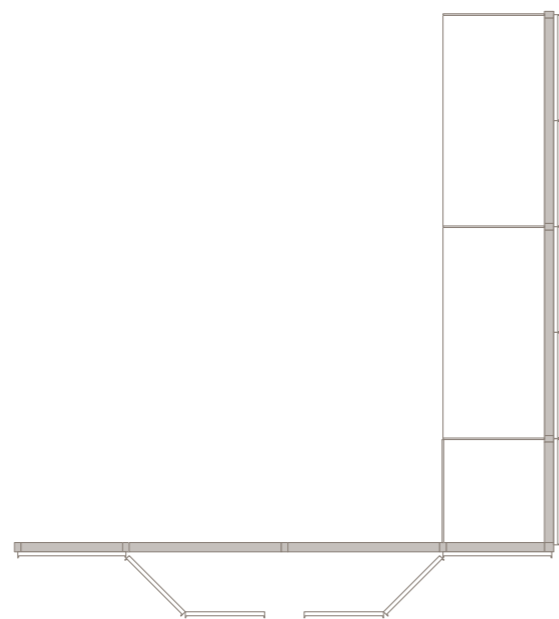
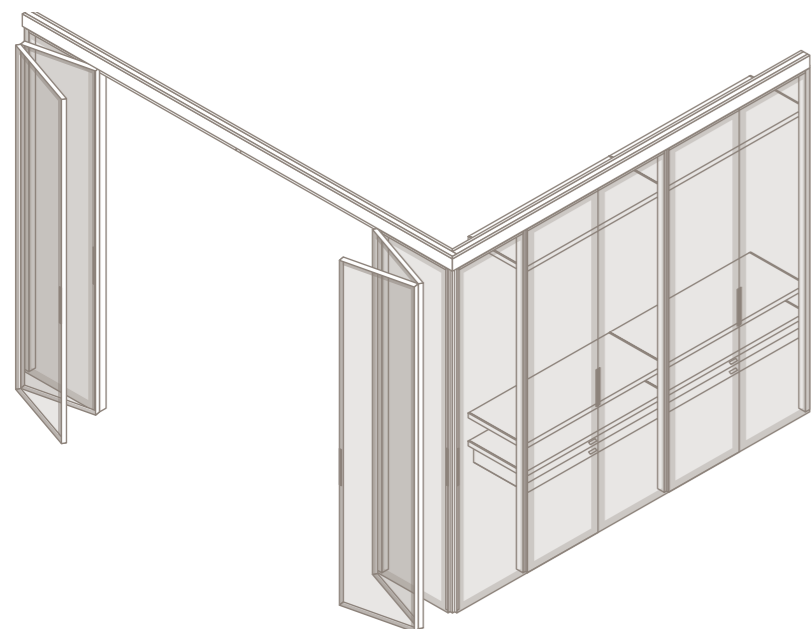

Possibilità di creare aree chiuse definendo perimetri a 2 o 3 lati con Palo Alto Free, con possibilità di accesso tramite portali realizzabili con ante Rex RX6.

It is possible to set up enclosed areas by defining 2-sided or 3-sided perimeters partitioning with Palo Alto Free, access can be achievable with Rex RX6 doors.

PALO ALTO FREE
CABINA FREE CON PORTALI RX6 _ FREE POD WITH RX6 DOOR PASSAGE

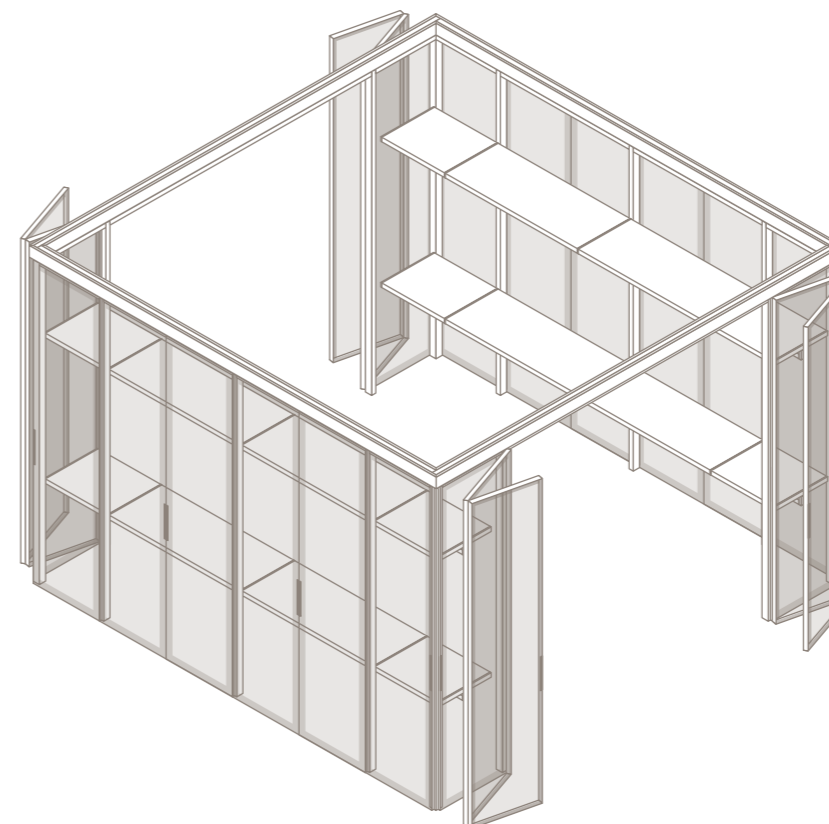

Possibilità di creare cabine armadio di dimensioni variabili delimitando un perimetro su 4 lati interamente con Palo Alto Free, completamente indipendente e svincolato dalle pareti con solo fissaggio terra-soffitto. Possibilità di accesso tramite portali realizzabili con ante Rex RX6.

Possibility of creating walk-in closets of different sizes by delimiting a perimeter on 4 sides entirely with Palo Alto Free, completely independent and released from the walls with only ground-ceiling fixation.

ANTE _ DOORS

Sommario _ *Index*

280 Narcisse

286 Zeus

292 Rex

298 Puzzle

304 London

310 Milano

316 Brillanta

322 First

328 Tecno

NARCISSE

DESIGN CR&S MISURAEMME®

Narcisse, abbinamento tra tecnica e trasparenza, un connubio tra metallo e vetro.
L'anta ideale per chi ama esporre e vedere.

***Narcisse**, a combination between technique and transparency, metal and glass.
The ideal door for those who love to see and be seen.*



Aperture _ Openings

Palo Alto I-Box

battente _ *hinged*

scorrevole _ *sliding*

complanare _ *coplanar*



MODULARITÀ BATTENTE _ HINGED DOORS

284

Larghezza ante _ Door widths

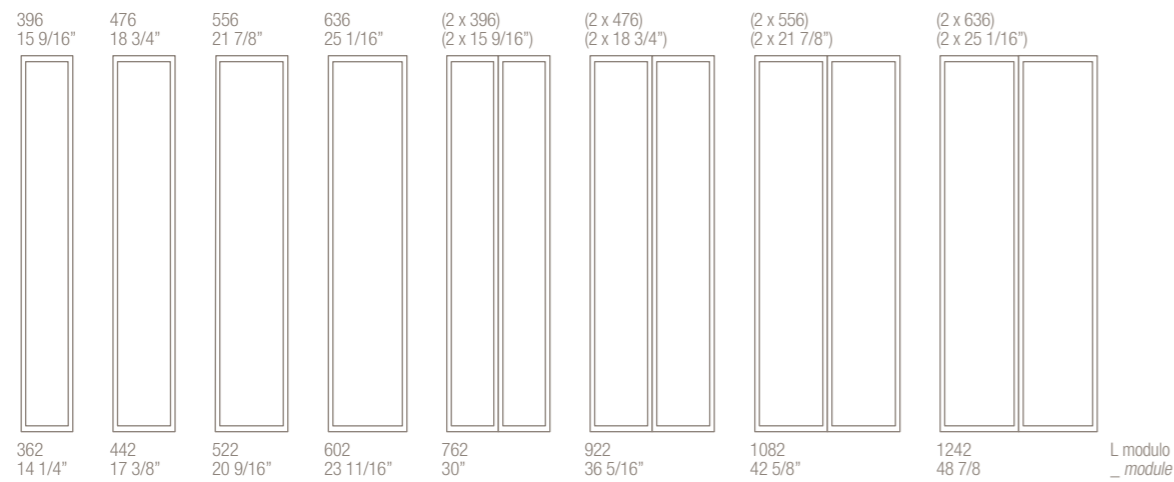

Altezza ante _ Door heights

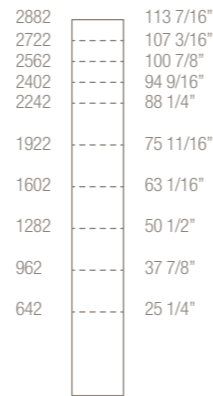

SCORREVOLE E COMPLANARE _ SLIDING AND COPLANAR DOORS

Larghezza ante _ Door widths

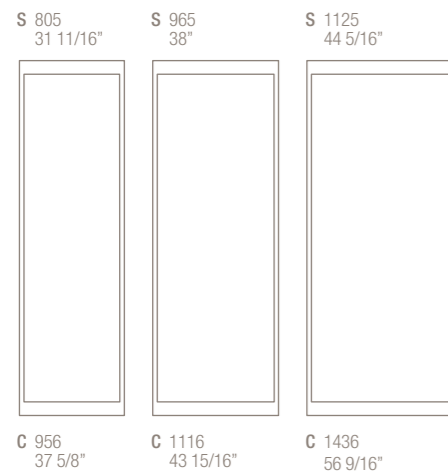

Altezza ante _ Door heights

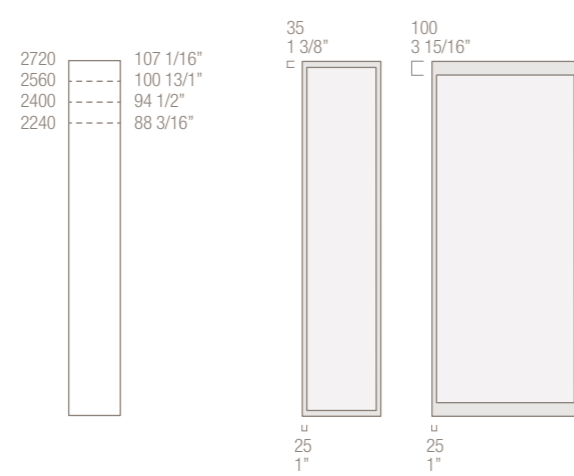

CORNICE VERNICIATA _ VARNISHED FRAME

SEZIONE ANTA _ DOOR SECTION

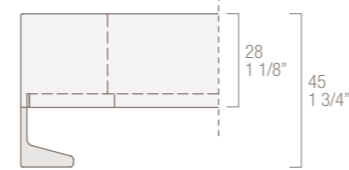

MANIGLIA _ HANDLE

	B	S	C	CS
Narcisse	●	●	●	

- B** battente _ hinged
- S** scorrevole _ sliding
- C** coplanare _ coplanar
- CS** cassetti _ drawers

MANIGLIA DEDICATA _ SPECIFICALLY DESIGNED HANDLE



L. 15 X P. 45 X H. 200 mm

CERNIERA DEDICATA _ SPECIFICALLY DESIGNED HINGE



FINITURE ANTA _ DOOR FINISHINGS

285

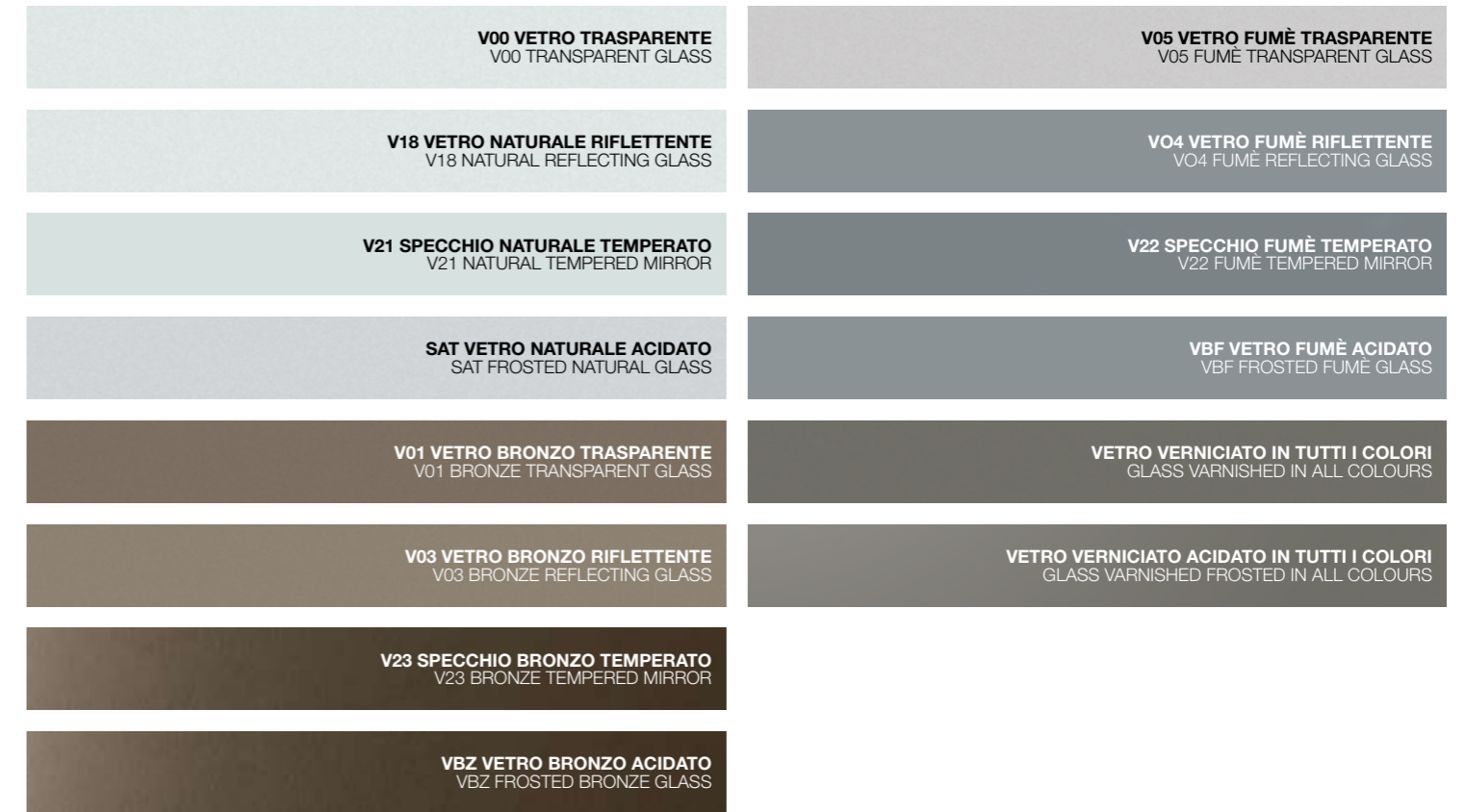

FINITURE TELAIO _ DOOR FRAME FINISHINGS



ZEUS

DESIGN CR&S MISURAEMME®

Eleganti profili metallici esaltano la versatilità dimensionale dei sistemi notte; accostati alle trasparenze del vetro, conferiscono alle superfici un'estrema purezza formale. Le maniglie dedicate si innestano nel telaio per una soluzione contemporanea di grande valore estetico e funzionale.

Elegant metallic profiles enhance the dimensional versatility of night systems; combined with the transparency of glass, they lend an extreme formal purity to surfaces. The dedicated handles become part of the frame conveying a contemporary allure of beautiful aesthetics and high performance.



Aperture _ Openings

Palo Alto I-Box
battente _ *hinged*



MODULARITÀ BATTENTE _ HINGED DOORS

290

Larghezza ante _ Door widths

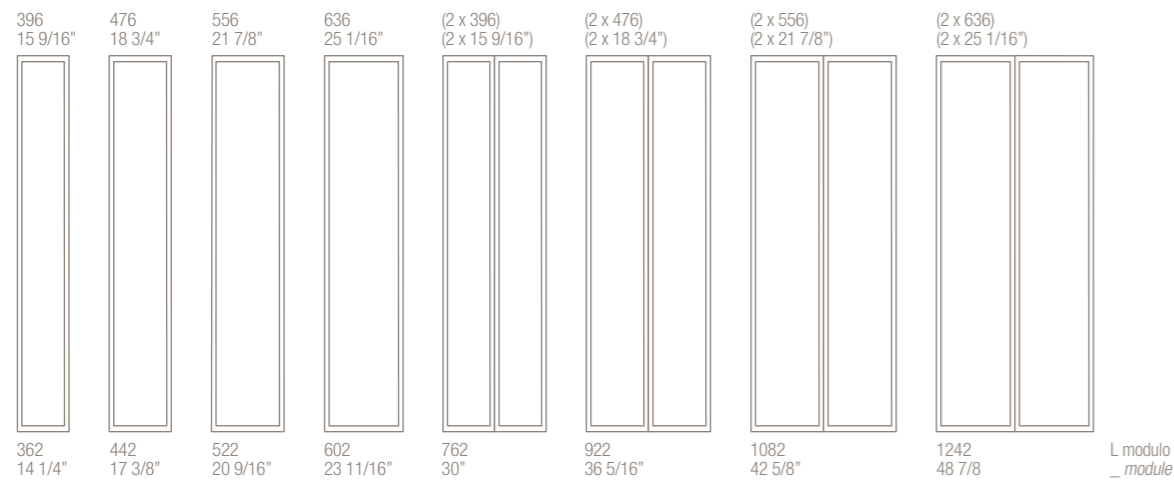

Altezza ante _ Door heights

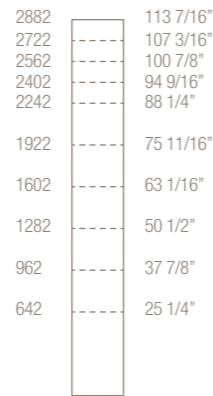

SEZIONE ANTA _ DOOR SECTION

Facciata vetro _ Glass facade

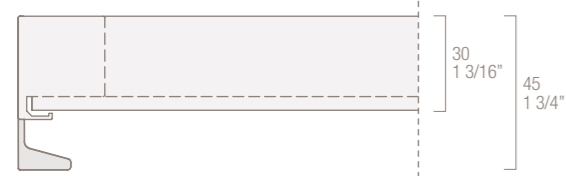

MANIGLIA _ HANDLE

	B	S	C	CS
Narcisse	●			

- B** battente _ hinged
- S** scorrevole _ sliding
- C** complanare _ coplanar
- CS** cassetti _ drawers

MANIGLIA DEDICATA _ SPECIFICALLY DESIGNED HANDLE



L. 15 X P. 45 X H. 200 mm

CERNIERA DEDICATA _ SPECIFICALLY DESIGNED HINGE



FINITURE ANTA _ DOOR FINISHINGS

291

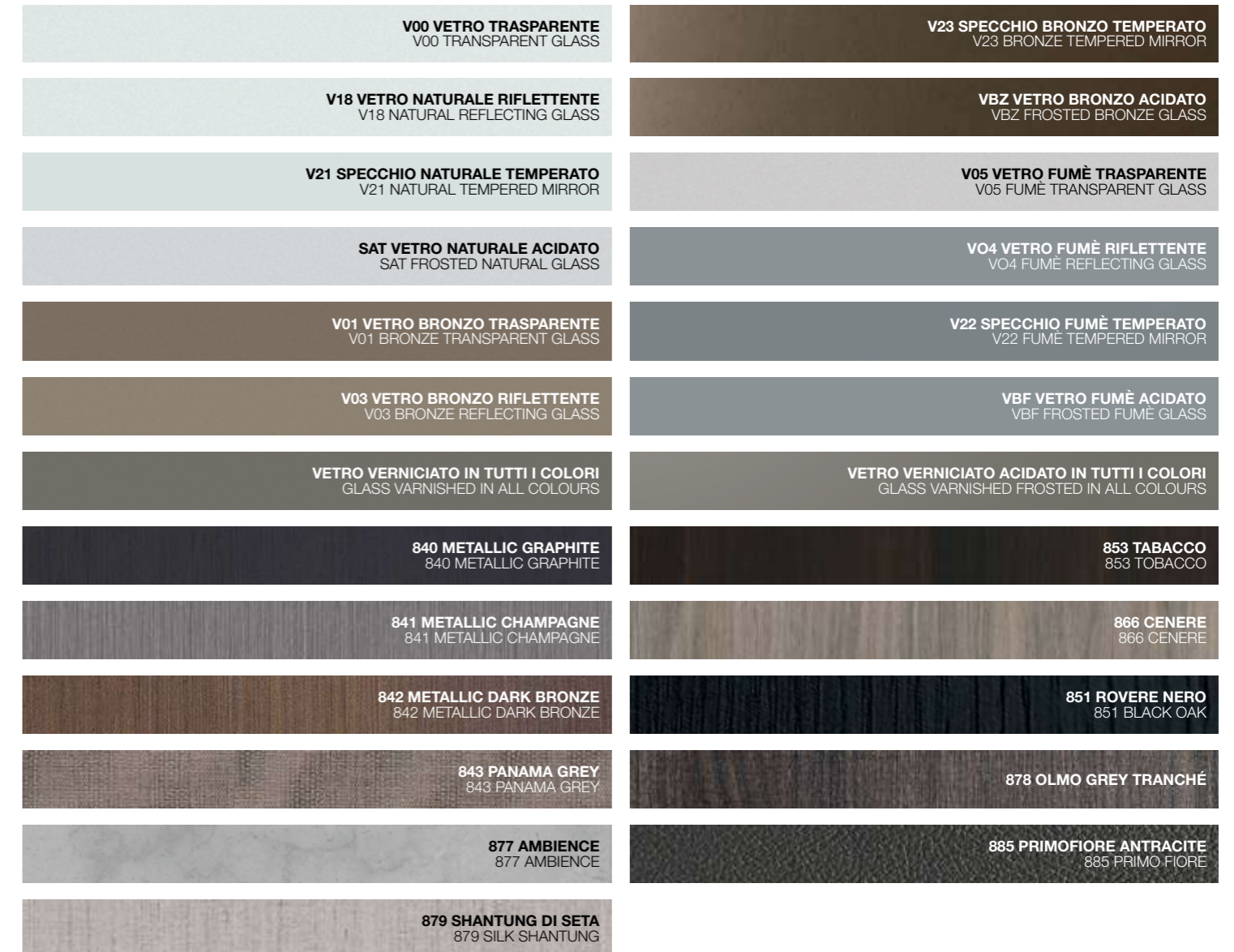

FINITURE TELAIO _ DOOR FRAME FINISHINGS



REX

DESIGN CR&S MISURAEMME®

L'anta a battente si evolve grazie a una cerniera dedicata che consente l'apertura a più di 180 gradi. I raffinati accenti metallici del telaio scandiscono e illuminano la zona notte, dando vita a un ricco e armonioso contrasto materico nella versione abbinata alle essenze rovere nero, tabacco e cenere.

The hinged door evolves thanks to a dedicated piece that allows the opening angle of more than 180 degrees. The refined metallic accents of the frame define and illuminate the night area, creating harmonious material contrasts in the versions combined with rovere nero, tabacco, and cenere essences.



Aperture _ Openings

Palo Alto I-Box

battente _ *hinged*
RX6

Palo Alto Free

battente _ *hinged*
RX6



MODULARITÀ BATTENTE _ HINGED DOORS

296

Larghezza ante _ Door widths

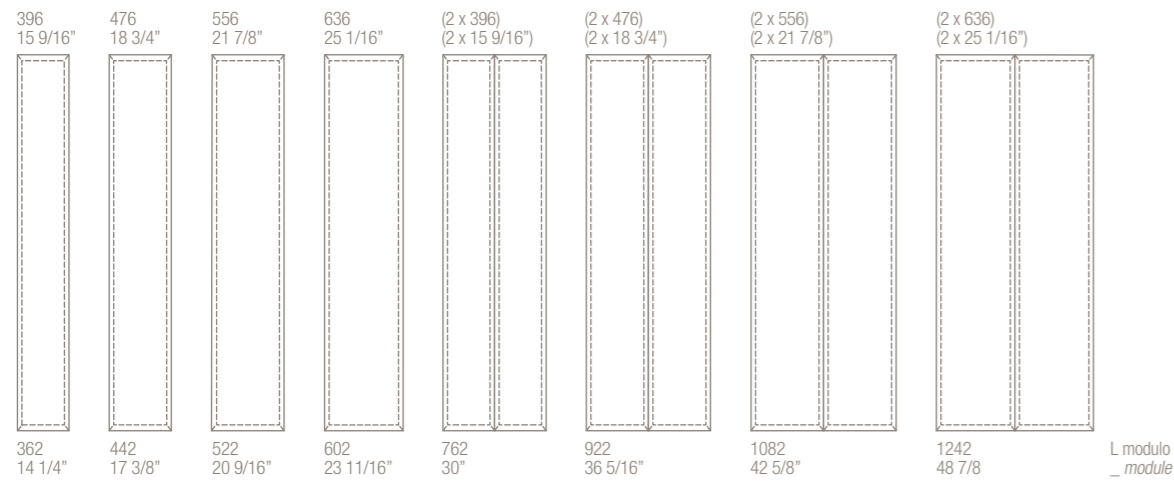

Altezza ante _ Door heights

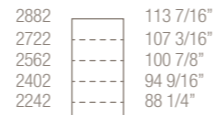

MODULARITÀ RX6 _ RX6 DOORS

Larghezza ante _ Door widths

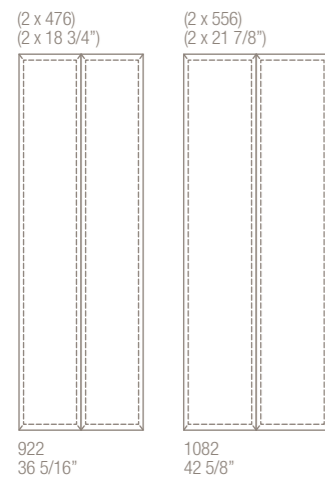

Altezza ante _ Door heights

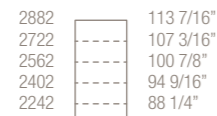

SEZIONE ANTA _ DOOR SECTION

Facciata vetro _ Glass facade

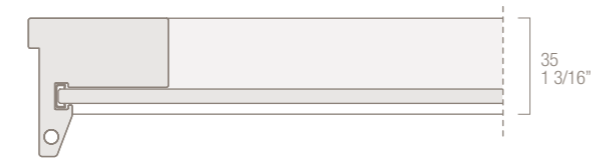

Anta battente apertura 180° _ hinged door opening 180°

MANIGLIA _ HANDLE

B S C CS
Rex ●

B battente _ hinged
S scorrevole _ sliding
C complanare _ coplanar
CS cassetti _ drawers

MANIGLIA DEDICATA _ SPECIFICALLY DESIGNED HANDLE



CERNIERA DEDICATA _ SPECIFICALLY DESIGNED HINGE



FINITURE ANTA _ DOOR FINISHINGS

297

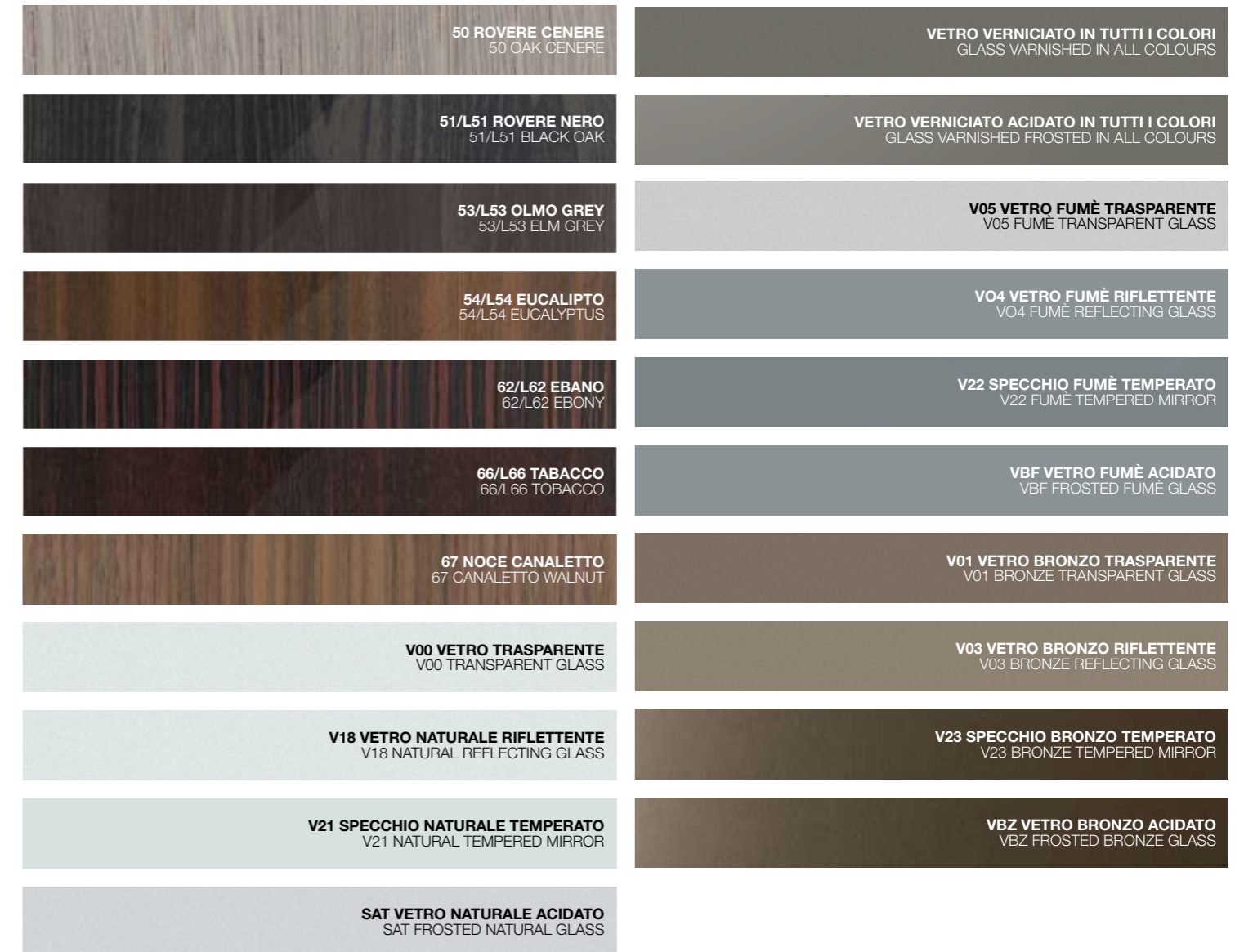

FINITURE TELAIO _ DOOR FRAME FINISHINGS



PUZZLE

DESIGN CR&S MISURAEMME®

Funzionale e sofisticata, l'anta **Puzzle** introduce la rigorosa geometria delle rette parallele e perpendicolari, scandendo e sottolineando una struttura moderna che diventa parte integrante con l'omonimo sistema a **boiserie Puzzle** e con l'architettura circostante.

*Functional and sophisticated, the **Puzzle** door introduces the rigorous geometry of parallel and perpendicular straight lines, punctuating and emphasizing a modern structure that becomes an integral part with the **Puzzle boiserie** system and the surrounding architecture.*

Aperture _ Openings

Palo Alto I-Box
battente _ *hinged*

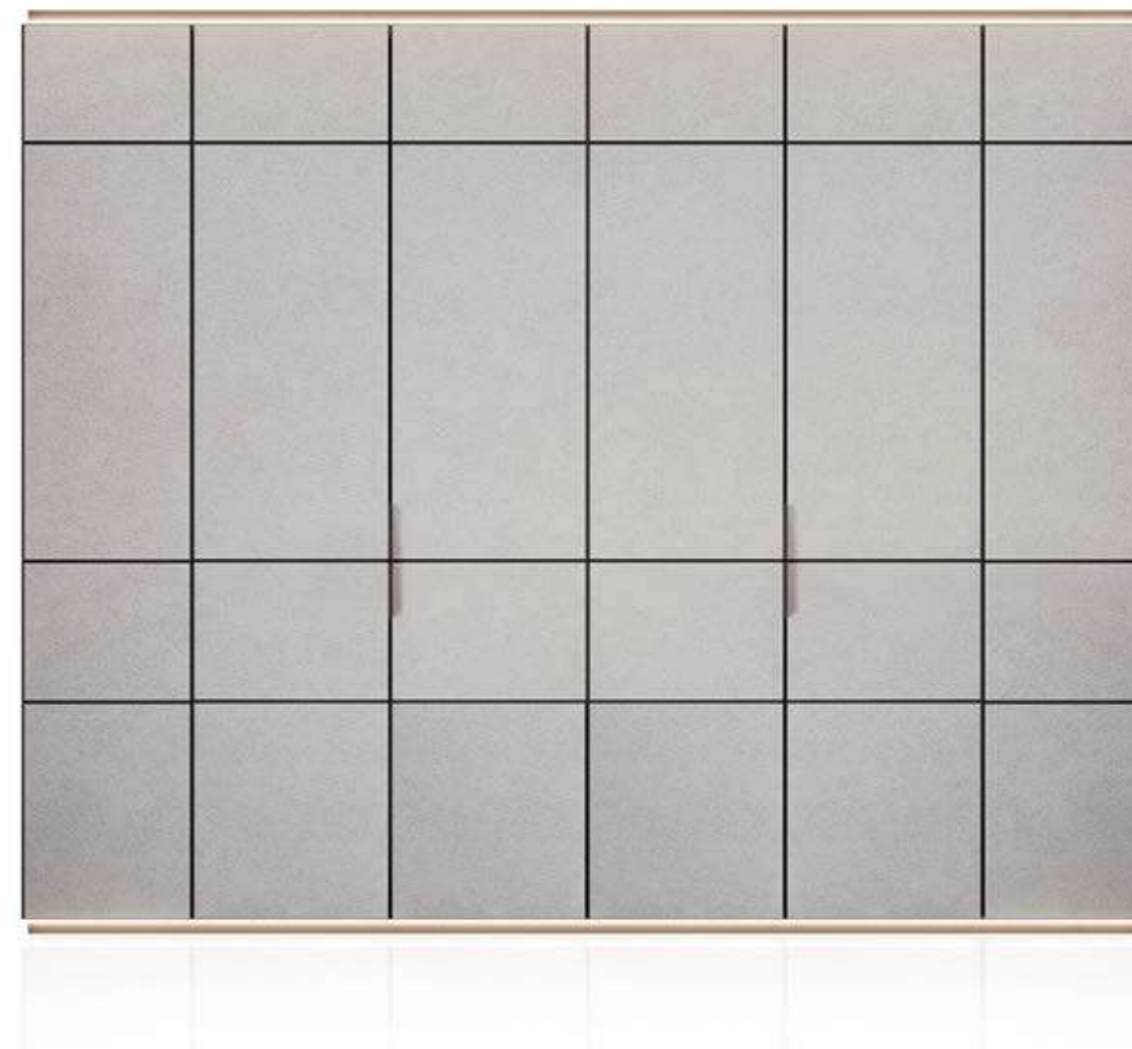



MODULARITÀ BATTENTE _ HINGED DOORS

302

Larghezze ante _ Door widths

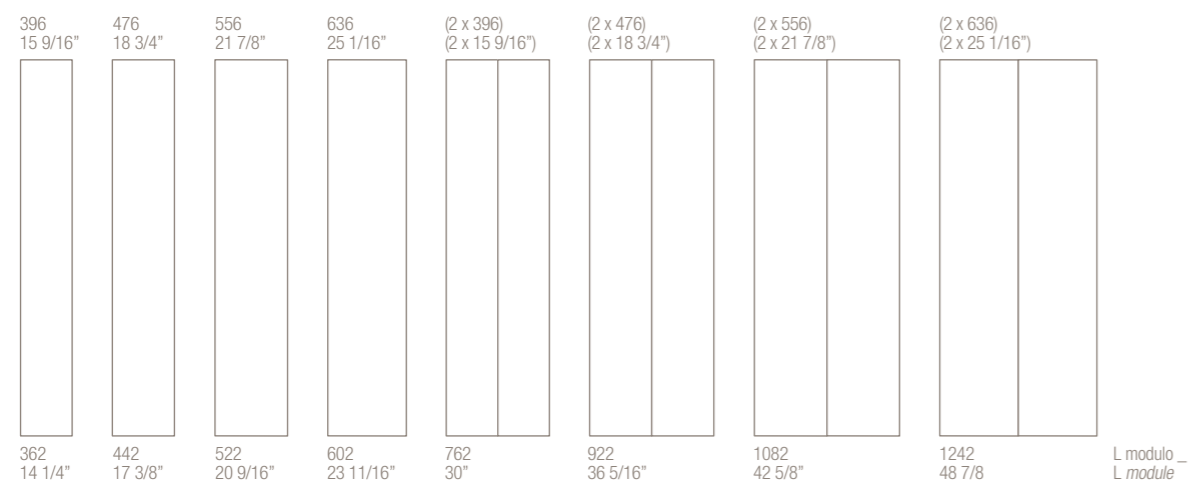

Altezza ante _ Door heights

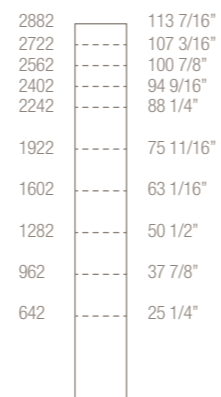

SCHEMA SEZIONI _ SECTION SCHEME

MANIGLIA _ HANDLE

B S C CS
Puzzle ●

B battente _ hinged
S scorrevole _ sliding
C complanare _ coplanar
CS cassetti _ drawers

MANIGLIA DEDICATA _ SPECIFICALLY DESIGNED HANDLE



FINITURE ANTA _ DOOR FINISHINGS

303



FINITURE TELAIO _ DOOR FRAME FINISHINGS



LONDON

DESIGN CR&S MISURAEMME®

Particolari sofisticati per l'anta **London** che crea un ambiente dinamico e raffinato attualissimo ma tradizionale. Il gioco dei quadrati in rilievo e delineati da un'impuntura con la maniglia inserita nel rettangolo che divide i quadrati creando un gioco armonico.

London Door with sophisticated details creates a dynamic and refined environment, current while at the same time traditional. The squares in relief and outlined by top stitching, along with a handle inserted into the rectangle which divides the squares, create a harmonious design.

Aperture _ Openings

Palo Alto I-Box

battente _ hinged
scorrevole _ sliding
complanare _ coplanar

Palo Alto Free

battente _ hinged





MODULARITÀ BATTENTE _ HINGED DOORS

308

Larghezza ante _ Door widths

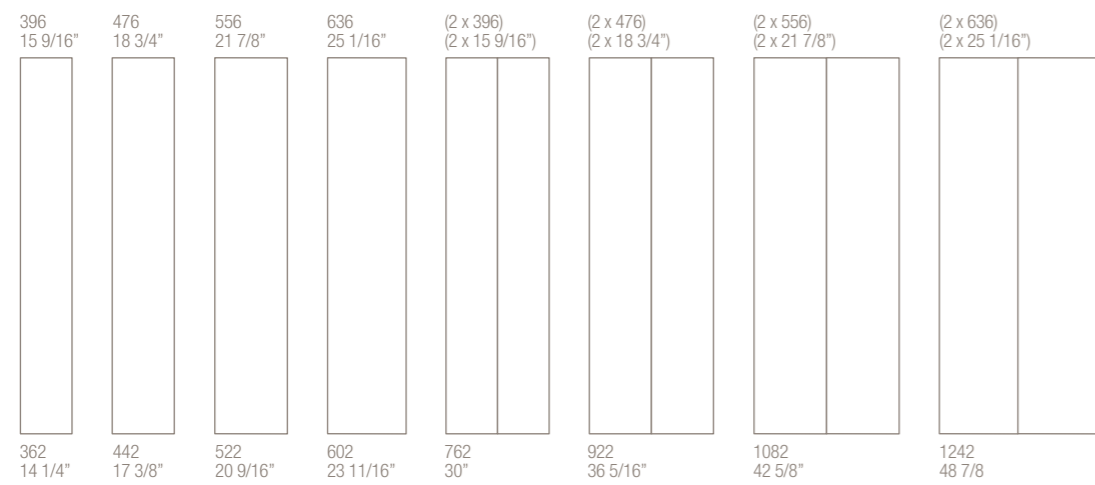

Altezza ante _ Door heights

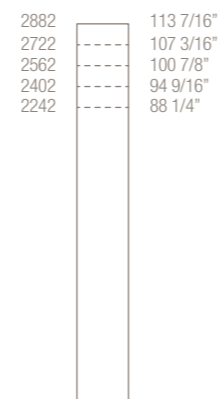

L modulo _
L module

SCORREVOLE E COMPLANARE _ SLIDING AND COPLANAR DOORS

Larghezza ante _ Door widths

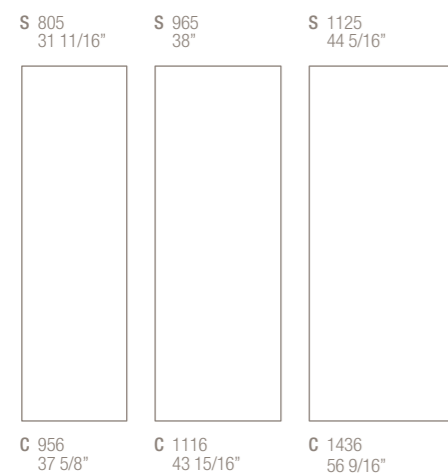

Altezza ante _ Door heights

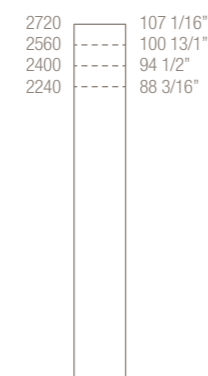

SEZIONE ANTA _ DOOR SECTION

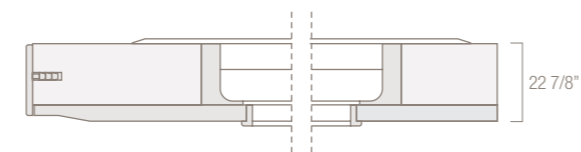

MANIGLIA _ HANDLE

	B	S	C	CS
Gost	•	•	•	
B	battente _ hinged	C	complanare _ coplanar	
S	scorrevole _ sliding	CS	cassetti _ drawers	

SCHEMA DISEGNO ANTA _ DOOR DESIGN SCHEME

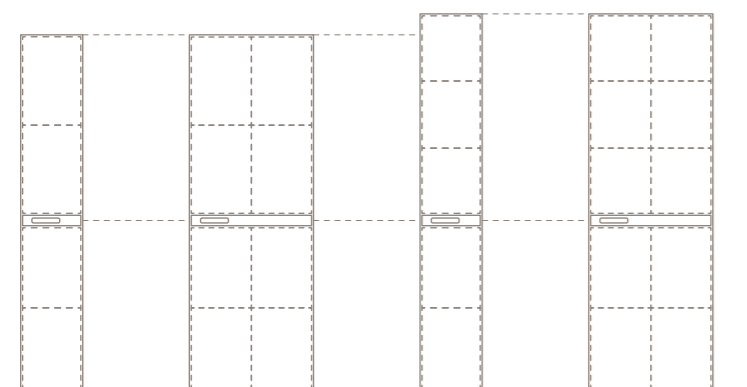

B _ Hinged H 2236	S H 2240 C H 2224	B _ Hinged H 2396 H 2556 H 2716 H 2876	S H 2400 / H 2560 / 2722 C H 2384 / H 2544 / 2706
----------------------	----------------------------	--	--

FINITURE ANTA _ DOOR FINISHINGS

309



FINITURE PROFILO e MANIGLIA _ PROFILE and HANDLE FINISHINGS



MANIGLIA DEDICATA _ SPECIFICALLY DESIGNED HANDLE



montaggio orizzontale _ horizontal fixture

MILANO

DESIGN CR&S MISURAEMME®

L'anta **Milano** consente una grande versatilità di maniglie, ante e finiture. Disponibile battente, scorrevole e coplanare, con ante ammortizzate di serie.

*The **Milano** door allows for great versatility of handles, doors and finishes. Available with hinged, sliding and coplanar doors with standard Soft-closing device.*



Aperture _ Openings

Palo Alto I-Box

battente _ hinged
scorrevole _ sliding
coplanare _ coplanar

Palo Alto Free

battente _ hinged



MODULARITÀ BATTENTE _ HINGED DOORS

314

Larghezze ante _ Door widths

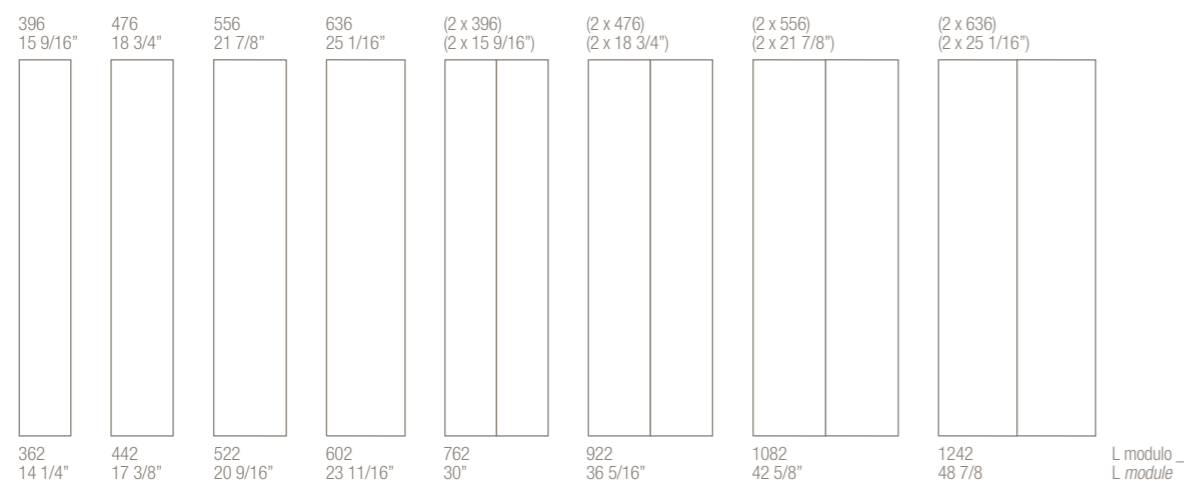

Altezza ante _ Door heights

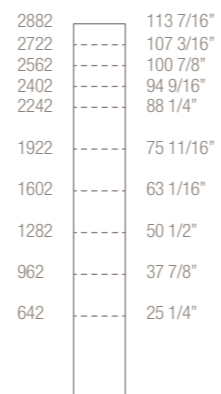

SCORREVOLE E COMPLANARE _ SLIDING AND COPLANAR DOORS

SEZIONE ANTA _ DOOR SECTION

Larghezze ante _ Door widths

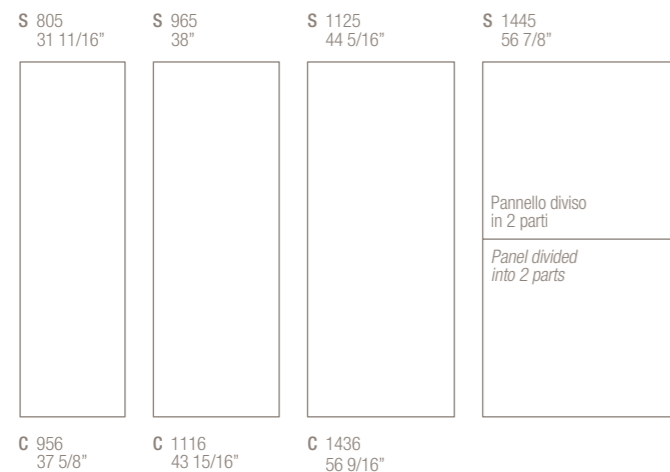

MANIGLIA _ HANDLE

	B	S	C	CS
Acanto	●	●		
Ashi	●			
Comma	●			●
Flap	●			
Gost	●	●	●	
Hook	●	●	●	
Lemma	●	●	●	
N3		●		
Narcisse	●			

	B	S	C	CS
Per	●		●	
Puzzle				
Regula	●	●		●
Revers	●		●	
Rex	●			
Rod	●	●	●	
Roller	●	●	●	
Split	●			

- B** battente _ hinged
- S** scorrevole _ sliding
- C** complanare _ coplanar
- CS** cassetti _ drawers

FINITURE ANTA _ DOOR FINISHINGS

315

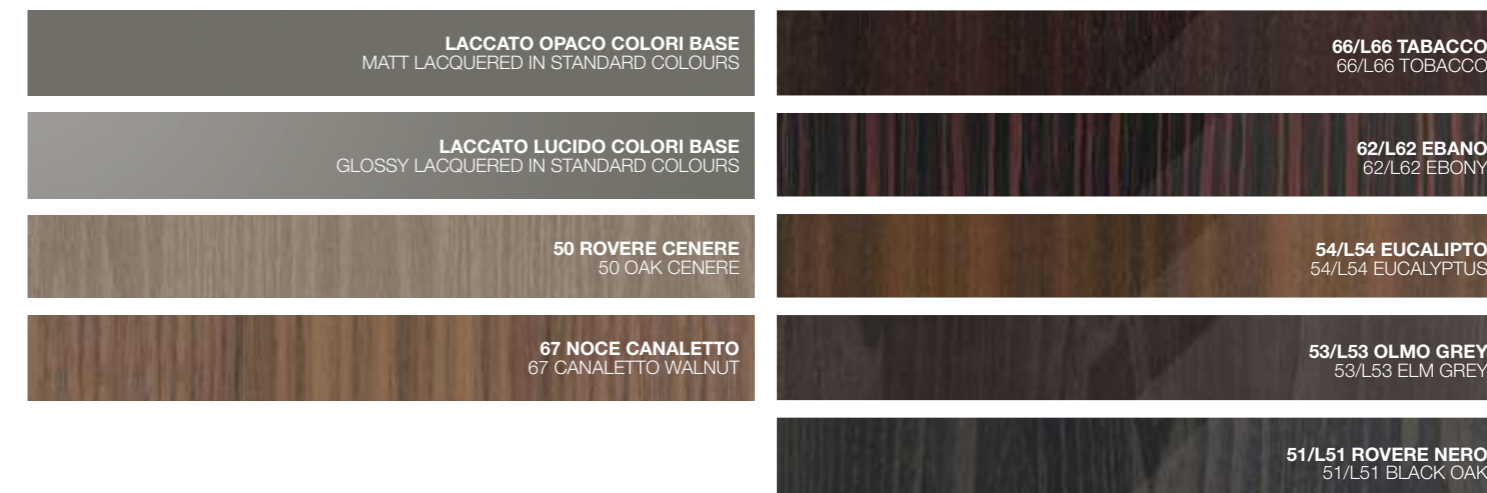

Ante battenti in essenza: rovere nero, tabacco, olmo grey, con vena verticale _ Hinged doors in wood: black oak, tobacco, elm grey, with vertical grain
 Anta scorrevole e complanare sempre con vena orizzontale _ Sliding and coplanar door always horizontal grain
 A richiesta è possibile variare il senso della vena _ The direction of the grain can be changed on request

BRILLANTA

DESIGN CR&S MISURAEMME®

Un mood fortemente creativo contraddistingue l'armadio **Brillanta**. Il suo stile originale è imbevuto di delicate suggestioni, giochi di luce e garbati contrasti materici.

*A very creative mood distinguishes the **Brillanta** wardrobe. Its original style, made with delicate suggestions, playing with light and contrasting materials, grants the environment a note of sublime elegance.*



Aperture _ Openings

Palo Alto I-Box

battente _ hinged

scorrevole _ sliding

complanare _ coplanar



MODULARITÀ BATTENTE _ HINGED DOORS

320

Larghezza ante _ Door widths

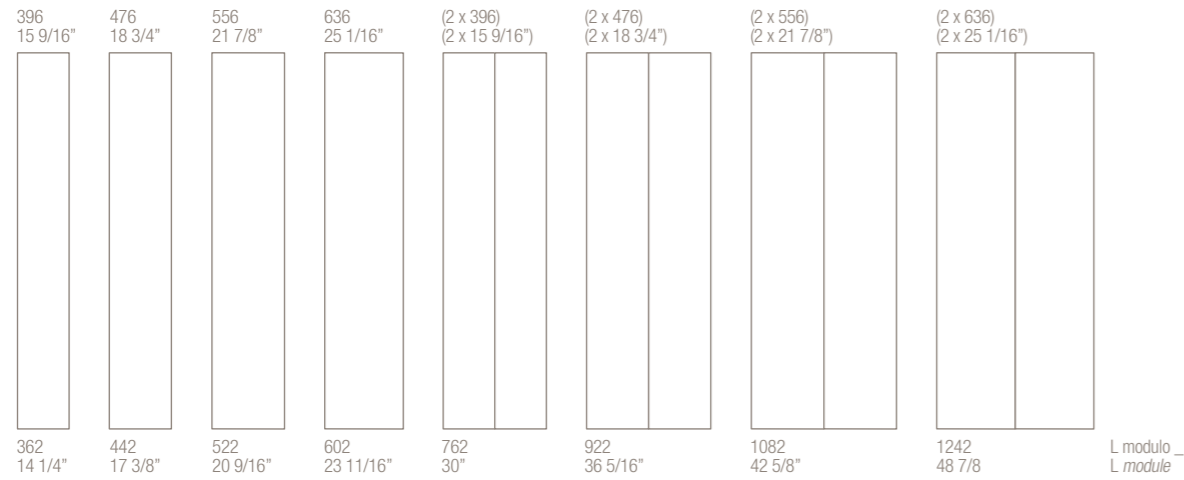

Altezza ante _ Door heights

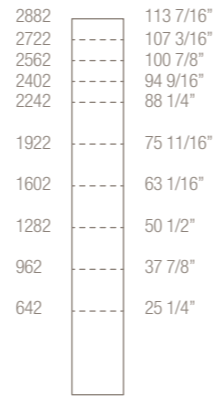

SCORREVOLE E COMPLANARE _ SLIDING AND COPLANAR DOORS

SEZIONE ANTA _ DOOR SECTION

Larghezza ante _ Door widths

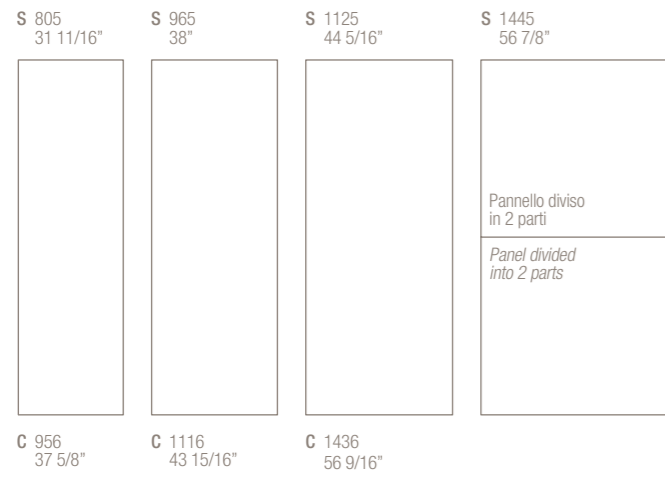

Altezza ante _ Door heights

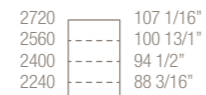

MANIGLIA _ HANDLE

	B	S	C	CS
Hook	●	●	●	
Lemma	●	●	●	
N3		●		
Rod	●	●	●	

B battente _ *hinged*
S scorrevole _ *sliding*
C complanare _ *coplanar*
CS cassetti _ *drawers*

FINITURE ANTA _ DOOR FINISHINGS

321



FINITURE TELAIO _ DOOR FRAME FINISHINGS



FIRST

DESIGN CR&S MISURAEMME®

Trasparenza, lucentezza, specularità, in una parola: **First**. Il gioco di riflessi, la levigatezza delle superfici e il design lineare e sempre attuale fanno di **First** un armadio da uno stile inconfondibile, dove il vetro diventa protagonista principale grazie alla straordinaria capacità di diffondere la luce e dilatare lo spazio.

*Transparency, gloss, mirrored image, in one word: **First**. The play of light, the smooth surface, linear design and always up-to-date design make **First** a wardrobe with a unique style, where glass is the main feature of the extraordinary capacity to diffuse light and expand space.*

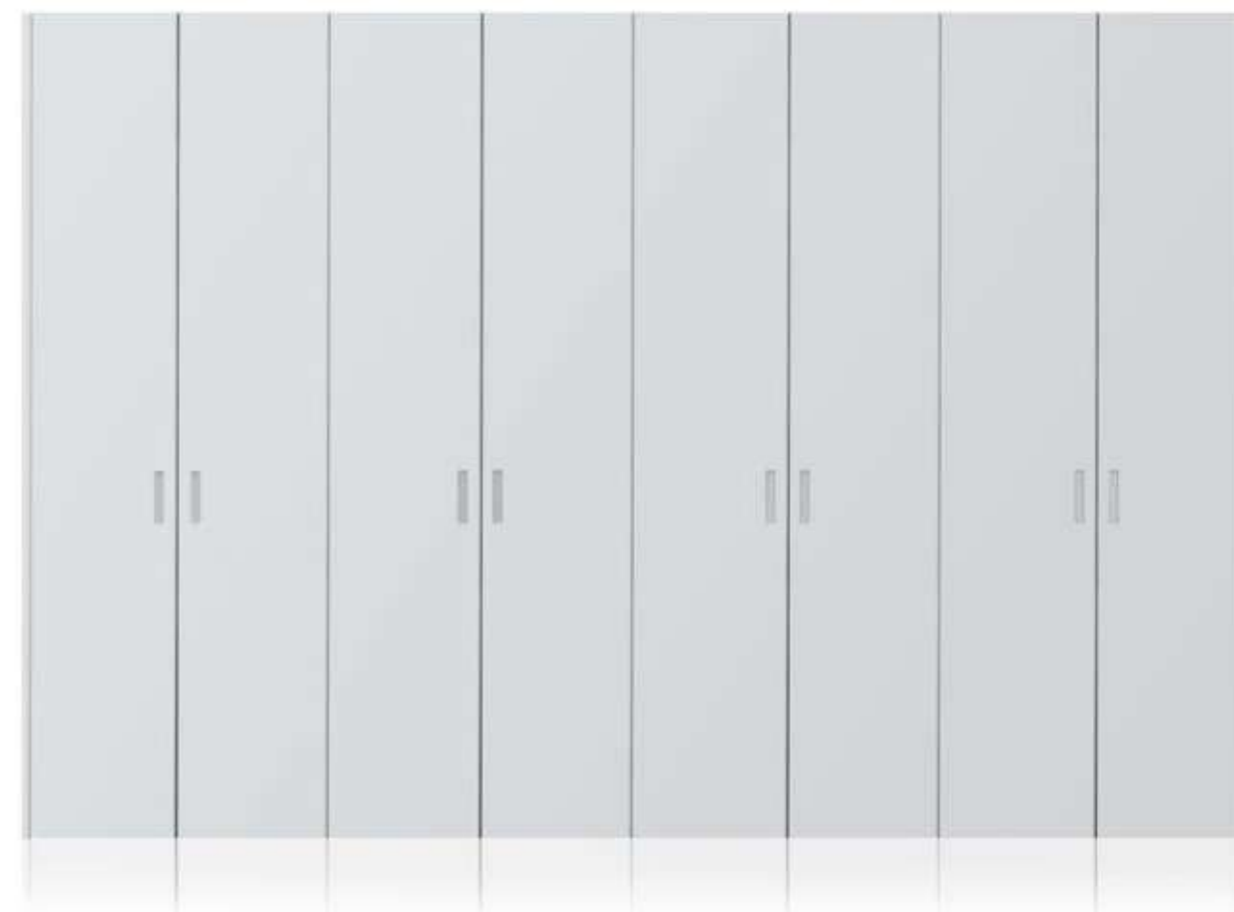

Aperture _ Openings

Palo Alto I-Box

battente _ hinged
scorrevole _ sliding
complanare _ coplanar

Palo Alto Free

battente _ hinged



MODULARITÀ BATTENTE _ *HINGED DOORS*

326

Larghezze ante _ *Door widths*

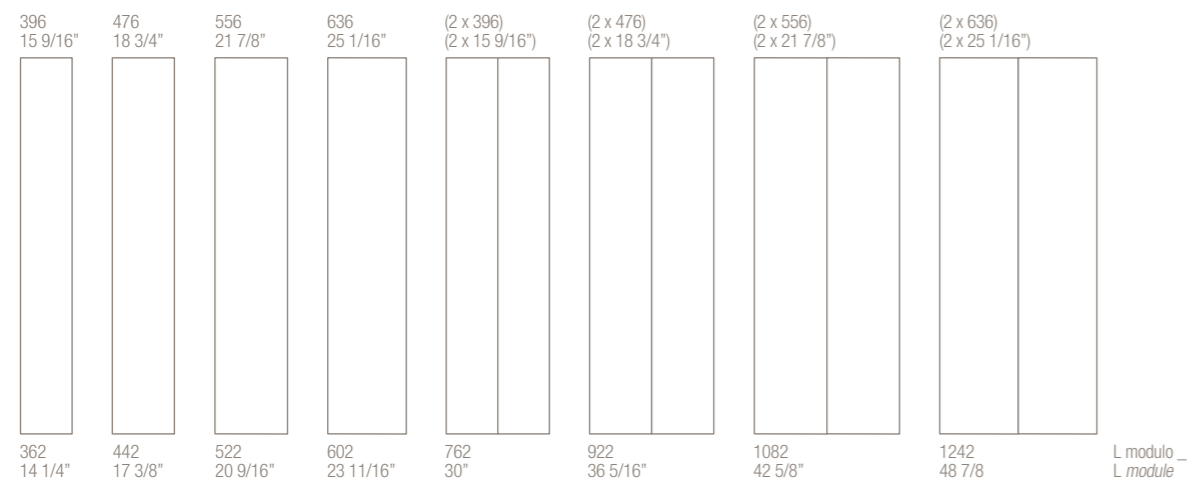

Altezza ante _ *Door heights*

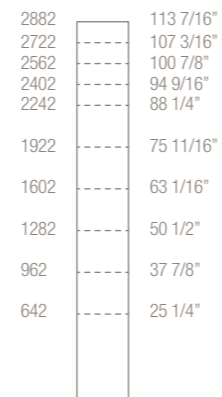

SCORREVOLE E COMPLANARE _ *SLIDING AND COPLANAR DOORS*

SEZIONE ANTA _ *DOOR SECTION*

Larghezze ante _ *Door widths*

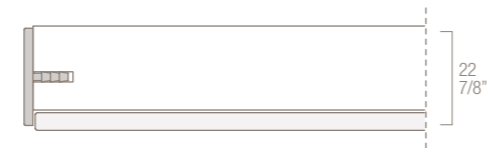
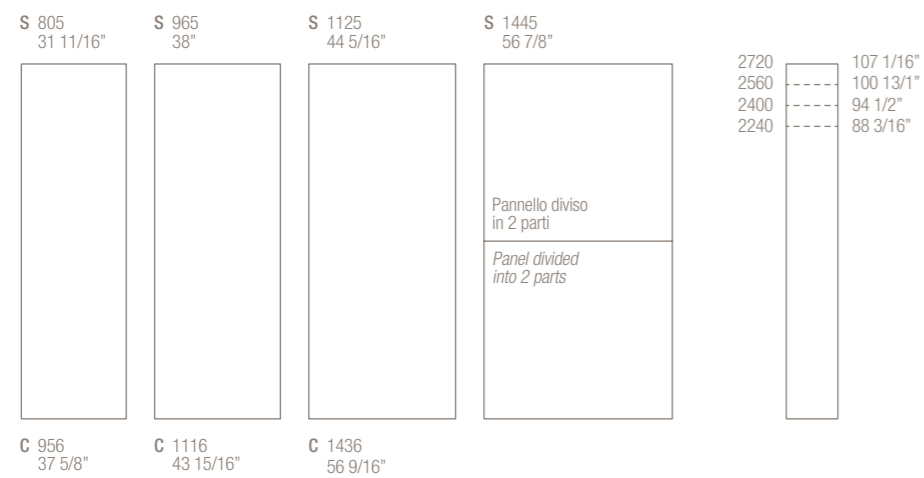

FINITURE ANTA _ *DOOR FINISHINGS*

327



FINITURE PROFILO e MANIGLIA _ *PROFILE and HANDLE FINISHINGS*



MANIGLIA _ *HANDLE*

	B	S	C	CS
Flap	•		•	
Gost	•	•	•	
Hook	•	•	•	
Lemma	•	•	•	
N3		•		
Rod	•	•	•	•

B battente _ *hinged*
 S scorrevole _ *sliding*
 C complanare _ *coplanar*
 CS cassetti _ *drawers*

TECNO

DESIGN CR&S MISURAEMME®

Ideale sintesi di ricercatezza e semplicità. Linee essenziali e pulite diventano sinonimo di un'eleganza senza tempo. Purezza formale e funzionalità viaggiano in parallelo.

Perfect synthesis of elegance and simplicity. Essential and clean lines become synonym for timeless elegance. Formal cleanliness and functionality go side by side.

Aperture _ Openings

Palo Alto I-Box

battente _ hinged
scorrevole _ sliding
complanare _ coplanar
cassetti _ drawers

Palo Alto Free

battente _ hinged





MODULARITÀ BATTENTE _ HINGED DOORS

332

Larghezza ante _ Door widths

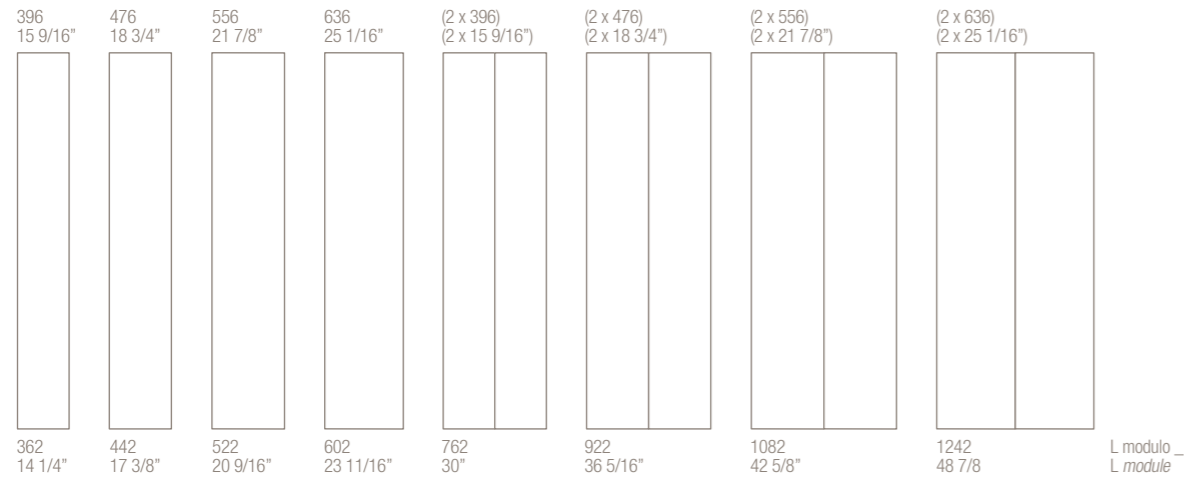

Altezza ante _ Door heights

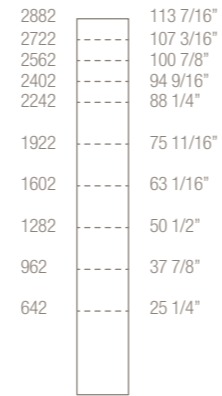

SCORREVOLE E COMPLANARE _ SLIDING AND COPLANAR DOORS

SEZIONE ANTA _ DOOR SECTION

Larghezza ante _ Door widths

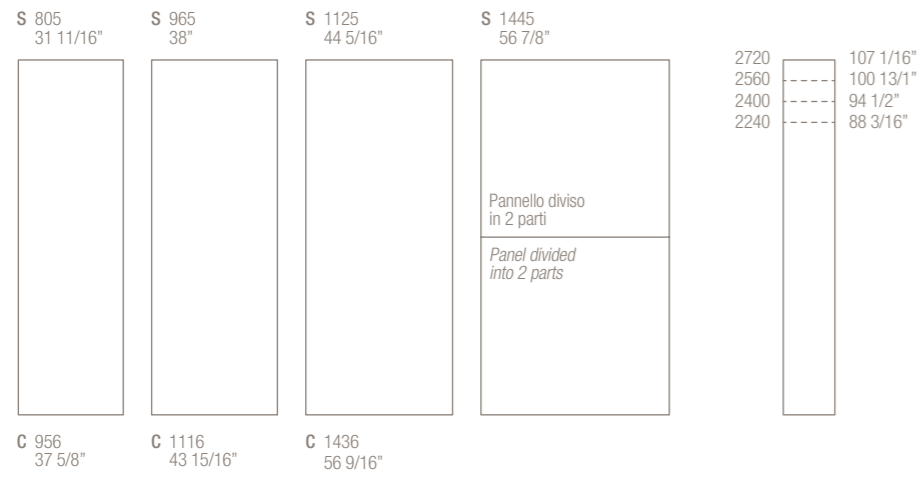

MANIGLIA _ HANDLE

	B	S	C	CS
Acanto	●	●		
Ashi	●			
Comma	●			●
Flap	●			
Gost	●	●	●	
Hook	●	●	●	
Lemma	●	●	●	
N3		●		
Narcisse	●			

	B	S	C	CS
Per	●		●	
Puzzle				
Regula	●	●		●
Revers	●		●	
Rex	●			
Rod	●	●	●	
Roller	●	●	●	
Split	●			

- B** battente _ *hinged*
- S** scorrevole _ *sliding*
- C** complanare _ *coplanar*
- CS** cassetti _ *drawers*

FINITURE ANTA _ DOOR FINISHINGS

333

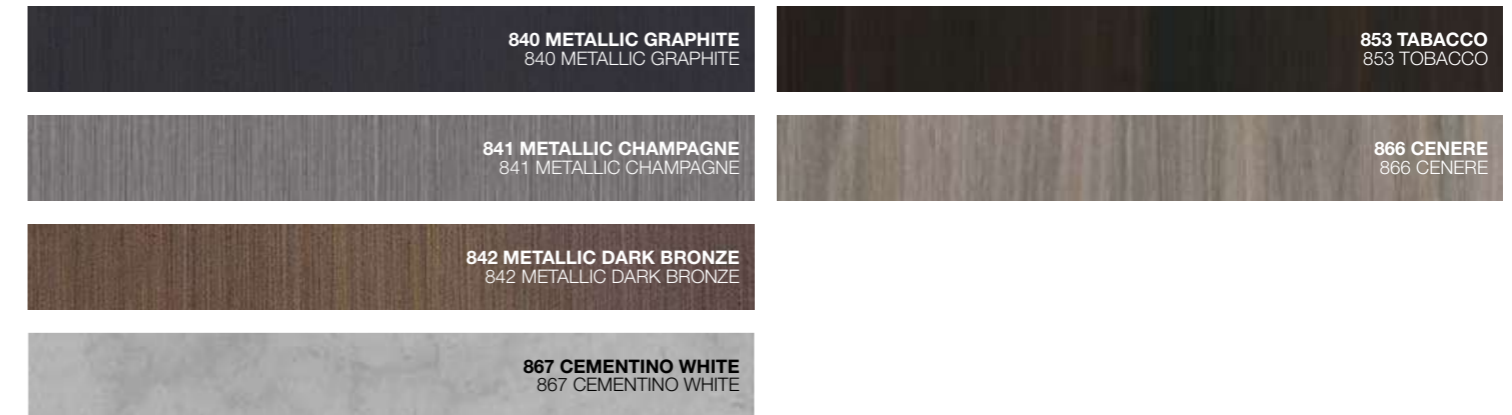

MANIGLIE _ *HANDLES*

Sommario _ *Index*

337 Roller

337 Rod

337 Comma

337 Hook

338 N3

338 Lemma

338 Acanto

338 Revers

339 Per

339 Gost

339 Ashi

339 Split

340 Narcisse

340 Rex

340 Regula

340 Flap

341 Puzzle

341 Key

341 Magnetic Key

Maniglie _ Handles

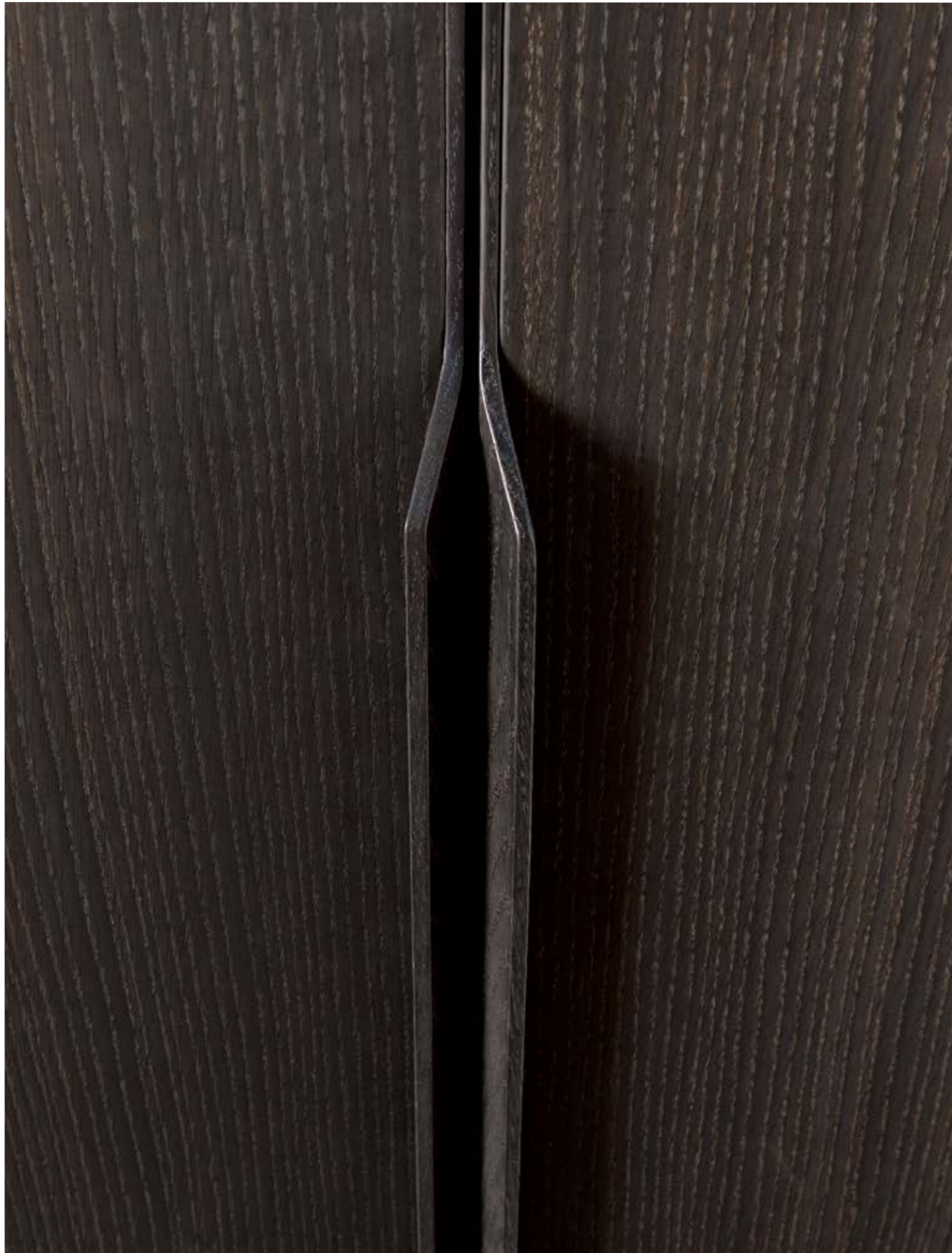

ROLLER

Ø 18 X P. 36 mm

Finiture

Canna di Fucile
Laccata a campionario

Finishes

Gunmetal
Lacquered in range colours

Ante _ Doors

Tecno
Milano

Aperture _ Openings

Battente _ *hinged*
Scorrevole _ *sliding**



ROD

L. 6 X P. 40 X H. 160 mm

Finiture

Canna di Fucile
Laccata a campionario

Finishes

Gunmetal
Lacquered in range colours

Ante _ Doors

Tecno
Milano

Aperture _ Openings

Battente _ *hinged*
Scorrevole _ *sliding**



COMMA

L. 60 X P. 25 X H. 60 mm

Finiture

Canna di Fucile
Laccata a campionario

Finishes

Gunmetal
Lacquered in range colours

Ante _ Doors

Tecno
Milano

Aperture _ Openings

Battente _ *hinged*



HOOK

L. 15 X P. 45 X H. anta/door

Finiture

Canna di Fucile
Laccata a campionario

Finishes

Gunmetal
Lacquered in range colours

Ante _ Doors

Tecno
Milano

Aperture _ Openings

Battente _ *hinged*
Scorrevole _ *sliding**

Complanare _ *coplanar**

* Disponibile solo per Palo Alto I-Box _ Available only for Palo Alto I-Box

Maniglie _ *Handles*

N3
L. 8 X P. 50 X H. anta/door
Finiture
Canna di Fucile
Laccata a campionario
Finishes
Gunmetal
Lacquered in range colours
Ante _ Doors
Tecno
Milano
First
Brillante *

Aperture _ Openings
Scorrevole _ *sliding* *



LEMMA
L. 30 X P. 22 X H. anta/door
Finiture
Canna di Fucile
Laccata a campionario
Finishes
Gunmetal
Lacquered in range colours
Ante _ Doors
Tecno
Milano
First
Brillante *

Aperture _ Openings
Battente _ *hinged*
Scorrevole _ *sliding* *
Complanare _ *coplanar* *



PER
L. 38 X H. 223 mm
Finiture
Canna di Fucile
Laccata a campionario
Finishes
Gunmetal
Lacquered in range colours
Ante _ Doors
Tecno
Milano
Aperture _ Openings
Battente _ *hinged*
Complanare _ *coplanar* *



GOST
L. 28 X H. 160 mm
Finiture
Canna di Fucile
Laccata a campionario
Finishes
Gunmetal
Lacquered in range colours
Ante _ Doors
Tecno
Milano
First
London
Aperture _ Openings
Battente _ *hinged*
Scorrevole _ *sliding* *
Complanare _ *coplanar* *

** dedicata _ *dedicated*



ACANTO
L. 17 X P. 50 X H. anta/door
Finiture
Rovere Cenere
Rovere Nero
Olmo Grey
Tabacco
Finishes
Oak Cenere
Black Oak
Elm Grey
Tobacco
Ante _ Doors
Tecno
Milano
Aperture _ Openings
Battente _ *hinged*
Scorrevole _ *sliding* *



REVERS
L. 530 X P. 45 X H. 2560 max
Finiture cuoio
A campionario
Saddle leather finish
Range colours
Ante _ Doors
Tecno
Milano
Aperture _ Openings
Battente _ *hinged*
Complanare _ *coplanar* *



ASHI
L. 180 X P. 30 X H. 8 mm
Finiture
Canna di Fucile
Laccata a campionario
Finishes
Gunmetal
Lacquered in range colours
Ante _ Doors
Tecno
Milano
Aperture _ Openings
Battente _ *hinged*



SPLIT
L. 30 X P. 45 X H. anta/door
Finiture
Canna di Fucile
Laccata a campionario
Finishes
Gunmetal
Lacquered in range colours
Ante _ Doors
Tecno
Milano
Aperture _ Openings
Battente _ *hinged*

Maniglie _ Handles



NARCISSE

L. 15 X P. 45 X H. 200 mm

FinitureCanna di Fucile
Dark Bronze
Laccata a campionario**Finishes***Gunmetal*
Dark Bronze
*Lacquered in range colours***Ante _ Doors**Zeus *
Narcisse *
Tecno
Milano**Aperture _ Openings**Battente _ *hinged*

REX

Ø 8 X P. 35 X H. 120 mm

FinitureCanna di Fucile
Dark Bronze
Laccata a campionario**Finishes***Gunmetal*
Dark Bronze
*Lacquered in range colours***Ante _ Doors**

Rex

Aperture _ OpeningsBattente _ *hinged*

PUZZLE

L. 8 X P. 15 X H. 200 mm

Finiture

Canna di Fucile

Finishes*Gunmetal***Ante _ Doors**

Puzzle

Aperture _ OpeningsBattente _ *hinged*

KEY

Chiave serratura

Lock Key



REGULA

L. 8 X P. 25 X H. 295 mm

FinitureCanna di Fucile
Laccata a campionario**Finishes***Gunmetal*
*Lacquered in range colours***Ante _ Doors**Tecno
Milano**Aperture _ Openings**Battente _ *hinged*

FLAP

180 X H.45 mm

Finiture

Satinato

Finishes*Satin***Ante _ Doors**Tecno
Milano
First**Aperture _ Openings**Battente _ *hinged*MAGNETIC
KEY

Chiave magnetica

Magnetic Key

ATTREZZATURA / EQUIPMENT

PALO ALTO I-BOX - FREE - WALL

Sommario _ *Index*

- | | |
|---|---|
| 344 Organizzazione interni _
<i>Inner unit organization</i> | 394 Elementi dedicati _
<i>Dedicated elements</i> |
| 356 Finitura attrezzatura _
<i>Equipment finishings</i> | 404 Elementi Hi-tech _
<i>Hi-tech elements</i> |
| 360 Ripiani _ <i>Shelves</i> | 412 Elemento ad Isola _
<i>Island element</i> |
| 366 Cassettiere _
<i>Chest of drawers</i> | 418 Accessori _ <i>Accessories</i> |
| 388 Elementi sospesi _
<i>Hanging elements</i> | |

Organizzazione interni _ *Inner unit organization*



Organizzazione interni _ Inner unit organization

ATTREZZATURA _ EQUIPMENT

PALO ALTO I-BOX



- 1.**
 2 ripiani
 1 tubo appendiabiti
 1 cassettiera sospesa 2 cassetti
 2 shelves
 1 hanging rail
 1 hanging chest of 2 drawers

- 3.**
 1 ripiano
 1 tubo appendiabiti
 1 contenitore portacamicie
 1 cassettiera a terra 4 cassetti
 1 shelf
 1 hanging rail
 1 shirts storage
 1 chest of 4 drawers

- 2.**
 1 tubo appendiabiti
 1 portapantaloni con vassoio portaoggetti
 1 hanging rail
 1 trousers holder with tray

- 4.**
 1 cassettiera sospesa 2 cassetti
 2 ripiani
 5 ripiani portascarpe inclinati
 1 hanging chest of 2 drawers
 2 shelves
 5 shoes inclined shelves

- 5.**
 2 ripiani
 1 tubo appendiabiti
 1 cassettiera a terra 4 cassetti
 2 shelves
 1 hanging rail
 1 chest of 4 drawers

- 6.**
 2 ripiani
 3 ripiani portascarpe
 1 cesto portabiancheria e 2 ripiani
 2 shelves
 3 shoes shelves
 1 laundry holder and 2 shelves 1

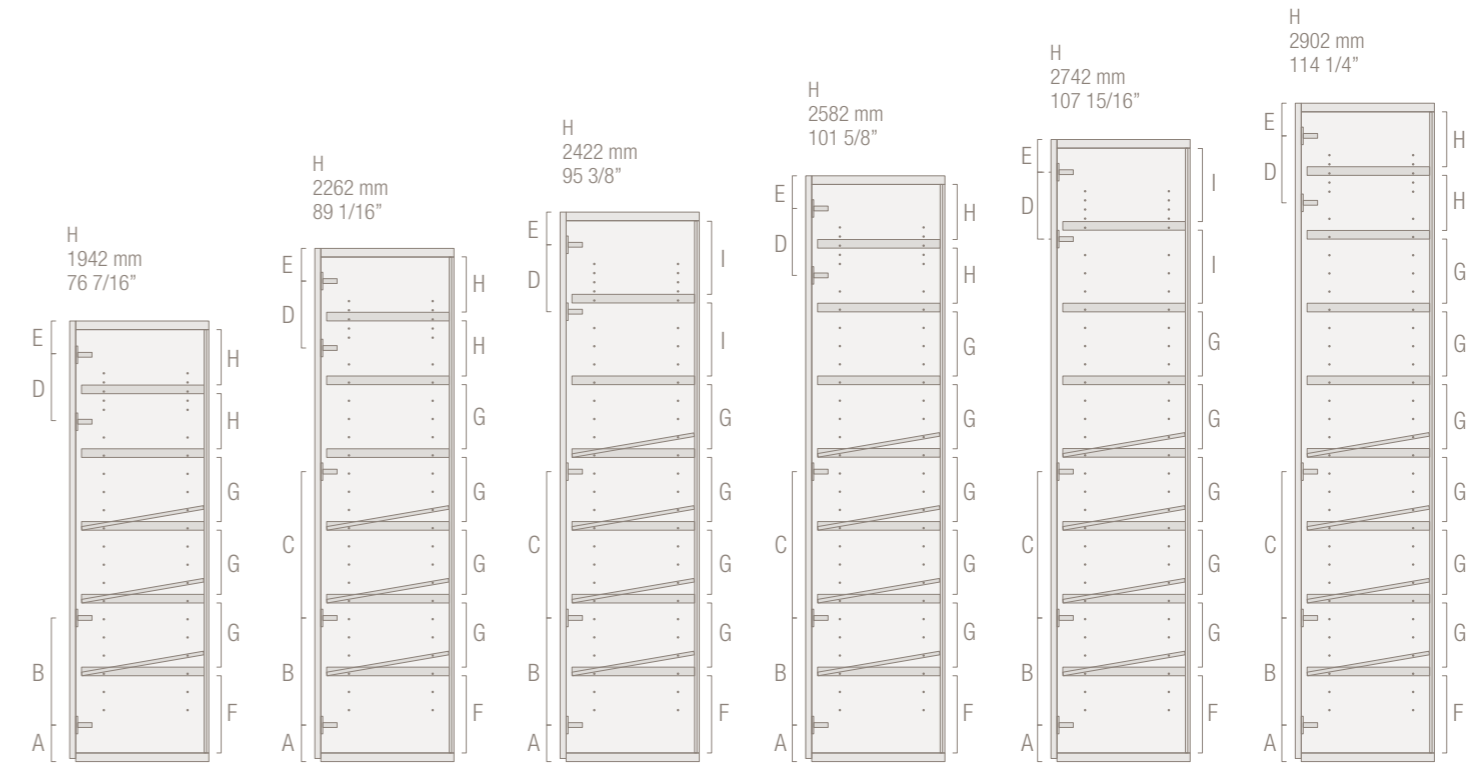

Altezza posizionamento cerniere Hinge height placement

A	B	C
161 mm 6 5/16"	472 mm 18 9/16"	645 mm 25 3/8"
D	E	
295 mm 11 5/8"	144 mm 5 11/16"	

Distanza tra le mensole Distance between shelves

F	G	H
341 mm 13 7/16"	282 mm 11 1/8"	242 mm 9 1/2"
I		
322 mm 12 11/16"		

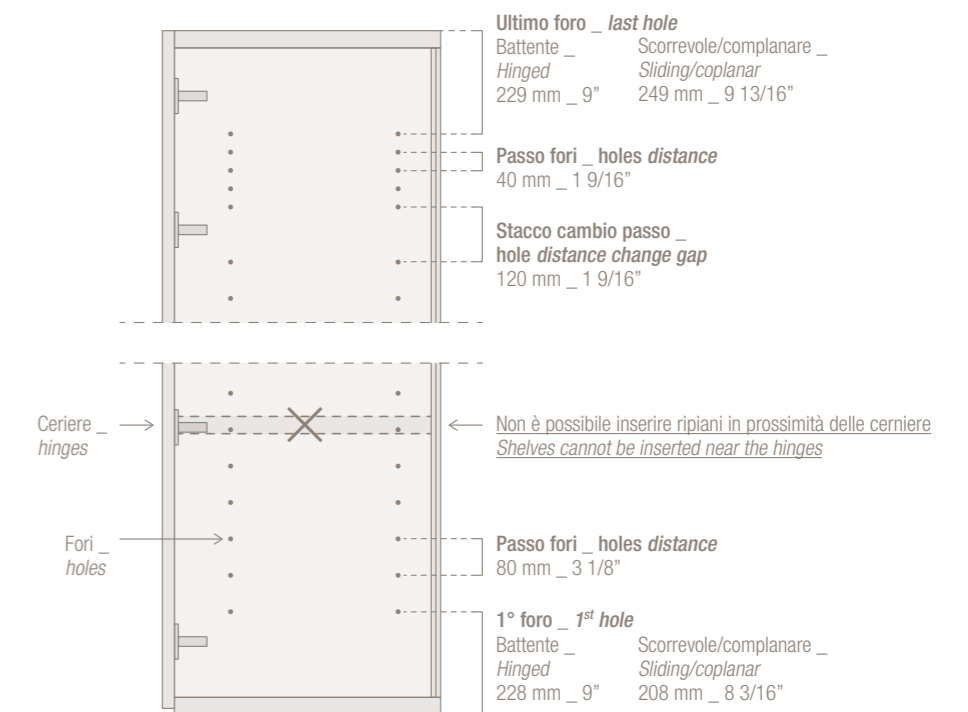

Organizzazione interni _ Inner unit organization

ATTREZZATURA _ EQUIPMENT

PALO ALTO FREE

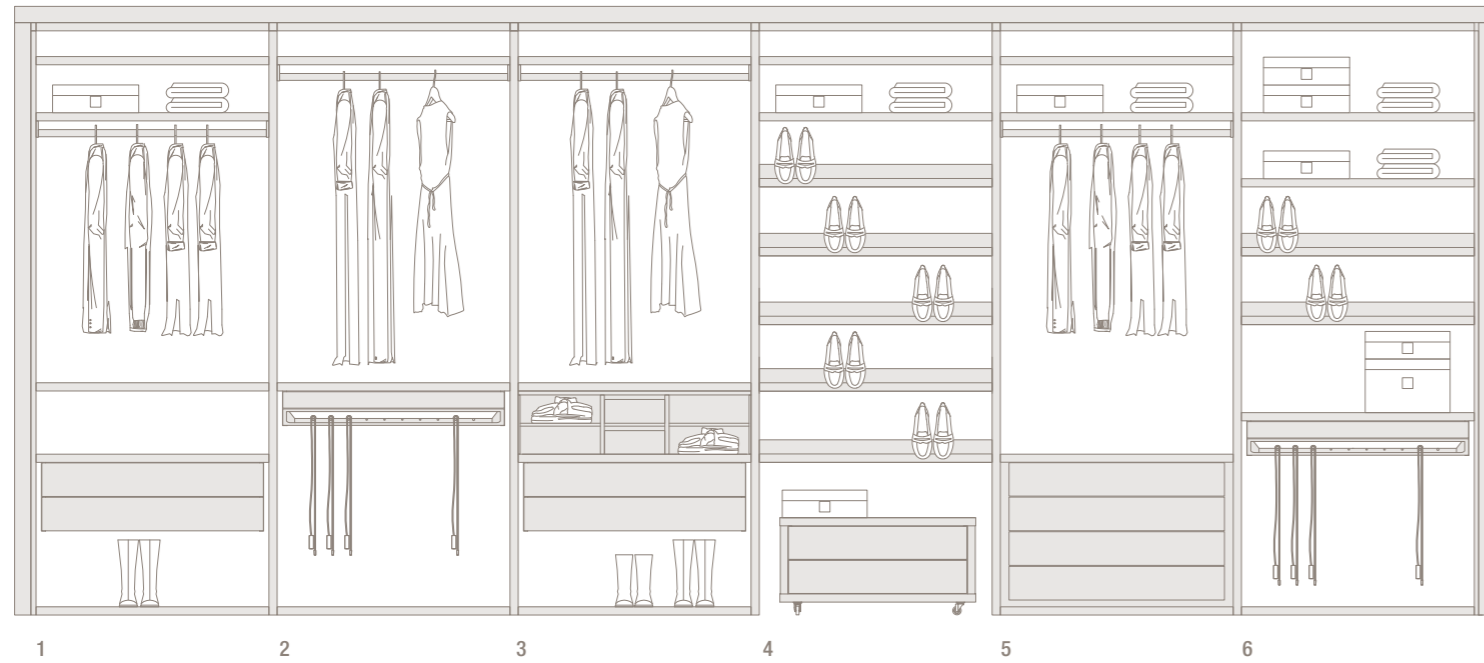

- 1.**
 2 ripiani
 1 tubo appendiabiti
 1 cassettera sospesa 2 cassetti
 2 shelves
 1 hanging rail
 1 hanging chest of 2 drawers

- 3.**
 1 ripiano
 1 tubo appendiabiti
 1 contenitore portacamice
 1 cassettera sospesa 2 cassetti
 1 shelf
 1 hanging rail
 1 shirts storage
 1 hanging chest of 2 drawers

- 2.**
 1 tubo appendiabiti
 1 portapantaloni con vassoio portaoggetti
 1 hanging rail
 1 trousers holder with tray

- 4.**
 2 ripiani
 5 ripiani portascarpe inclinati
 1 cassettera su ruote 2 cassetti
 2 shelves
 5 shoes shelves
 1 chest of 2 drawers with casters

- 5.**
 2 ripiani
 1 tubo appendiabiti
 1 cassettera a terra 4 cassetti
 2 shelves
 1 hanging rail
 1 chest of 4 drawers

- 6.**
 2 ripiani
 2 ripiani portascarpe
 1 portapantaloni con vassoio portaoggetti
 2 shelves
 3 shoes shelves
 1 trousers holder with tray

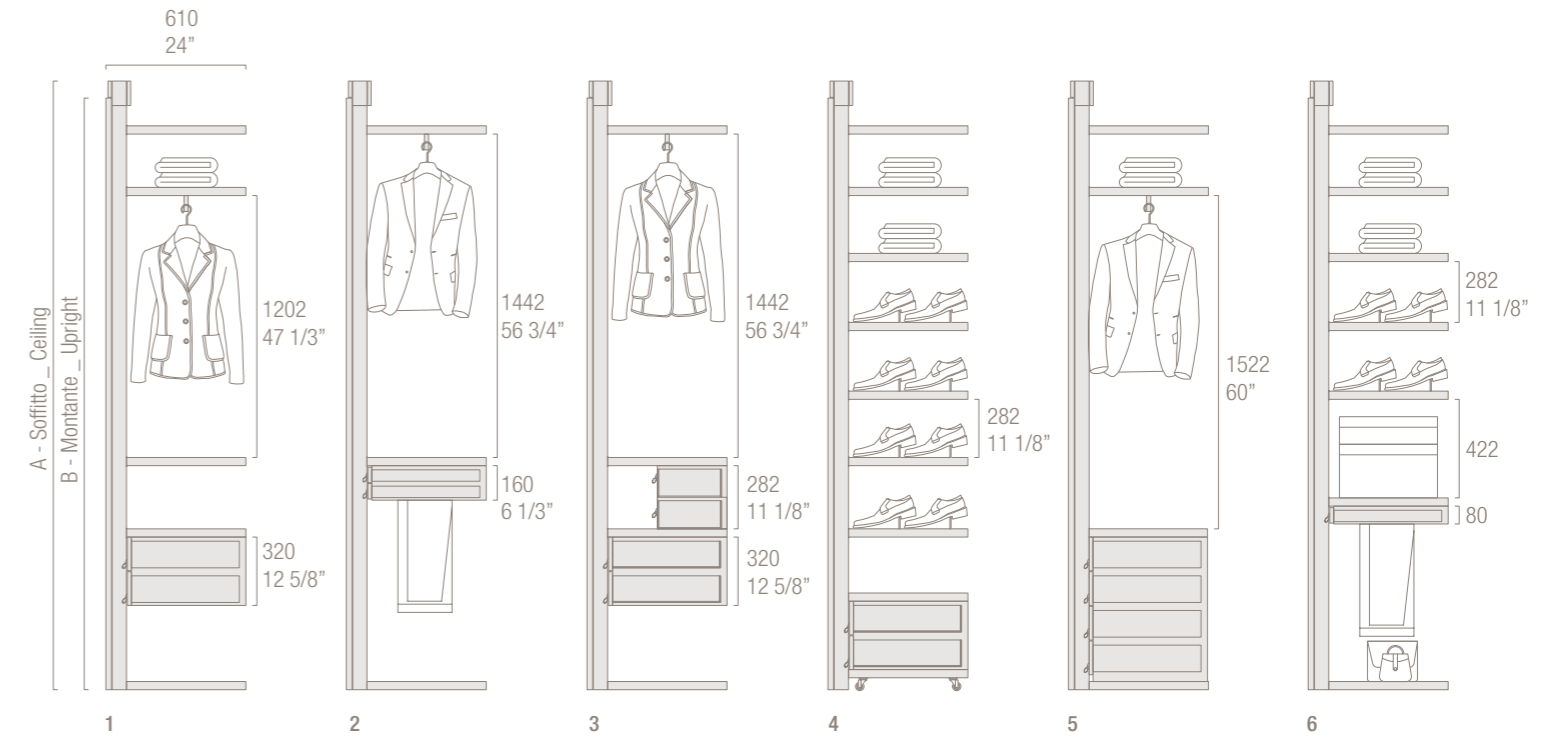

A - Altezze struttura fino a soffitto
Structure heights to ceiling
 2020 mm _ 79 1/2"
 2340 mm _ 92 1/8"
 2660 mm _ 104 3/4"
 2980 mm _ 117 5/16"

B - Altezza montante
Upright height
 1970 mm _ 77 9/16"
 2290 mm _ 90 3/16"
 2610 mm _ 102 3/4"
 2930 mm _ 115 3/8"

Spessore ripiani e staffe
Shelves and brackets thickness
 38 mm _ 1 1/2"

Passo cremagliera
 Rack drilling distance
 20 mm _ 13/16"



Organizzazione interni _ Inner unit organization

ATTREZZATURA _ EQUIPMENT

PALO ALTO WALL

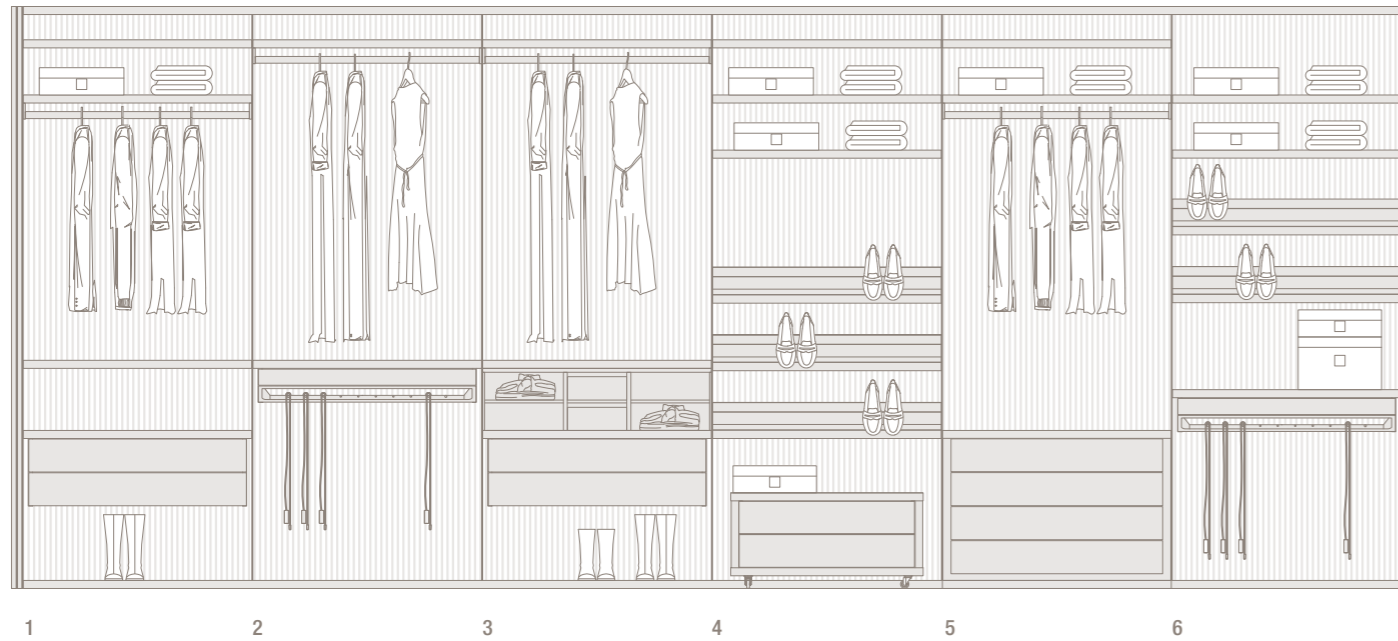

- 1.**
 2 ripiani
 1 tubo appendiabiti
 1 cassettera sospesa 2 cassetti
 2 shelves
 1 hanging rail
 1 hanging chest of 2 drawers

- 3.**
 1 ripiano
 1 tubo appendiabiti
 1 contenitore portacamice
 1 cassettera sospesa 2 cassetti
 1 shelf
 1 hanging rail
 1 shirts storage
 1 hanging chest of 2 drawers

- 2.**
 1 tubo appendiabiti
 1 portapantaloni con vassoio portaoggetti
 1 hanging rail
 1 trousers holder with tray

- 4.**
 2 ripiani
 5 ripiani portascarpe inclinati
 1 cassettera su ruote 2 cassetti
 2 shelves
 5 shoes shelves
 1 chest of 2 drawers with casters

- 5.**
 2 ripiani
 1 tubo appendiabiti
 1 cassettera a terra 4 cassetti
 2 shelves
 1 hanging rail
 1 chest of 4 drawers

- 6.**
 2 ripiani
 2 ripiani portascarpe
 1 portapantaloni con vassoio portaoggetti
 2 shelves
 3 shoes shelves
 1 trousers holder with tray

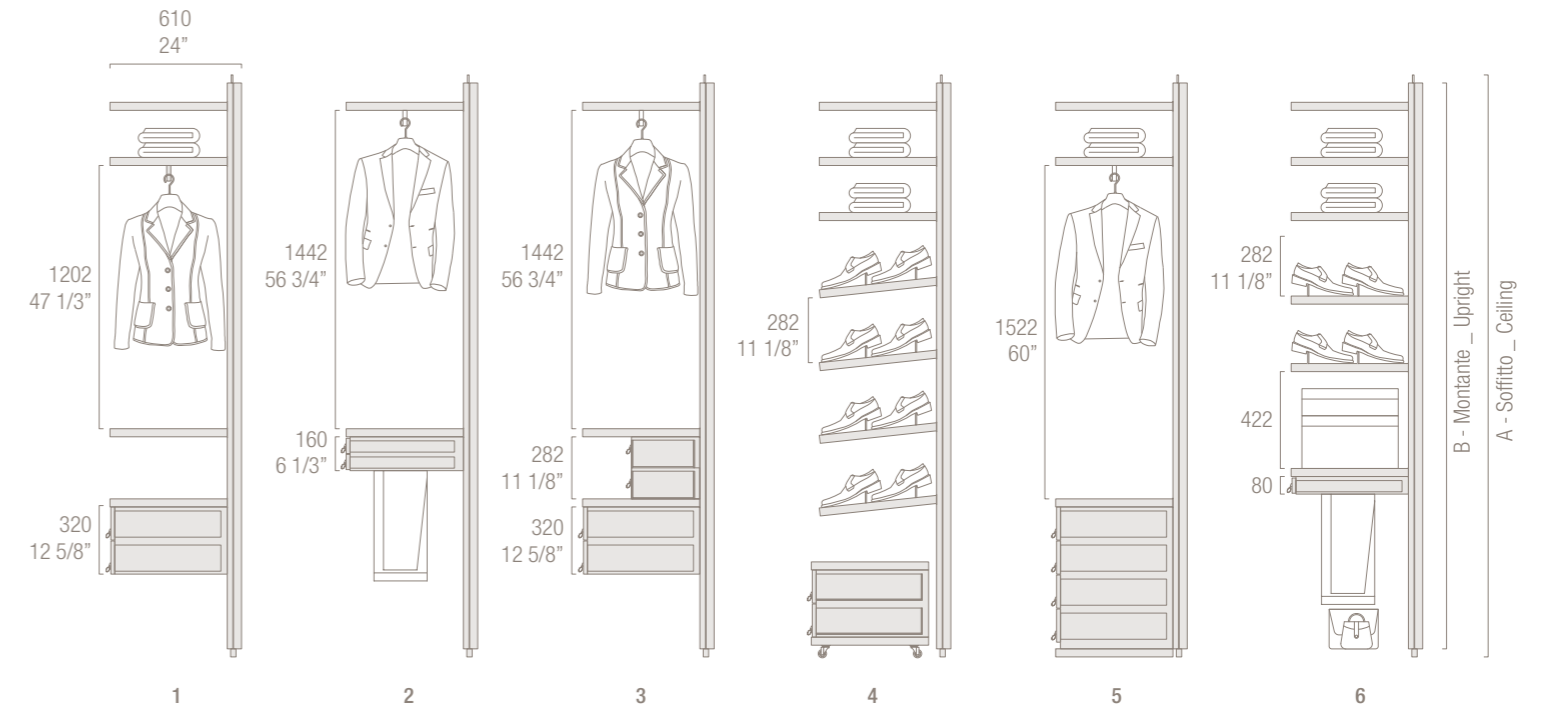

A - Altezze struttura fino a soffitto
Structure heights to ceiling

- 2040 mm _ 80 5/16"
- 2340 mm _ 92 1/8"
- 2500 mm _ 98 7/16"
- 2660 mm _ 104 3/4"
- 2820 mm _ 111"
- 2980 mm _ 117 5/16"

B - Altezza montante
Upright height

- 1940 mm _ 76 3/8"
- 2260 mm _ 89"
- 2420 mm _ 95 1/4"
- 2580 mm _ 101 9/16"
- 2740 mm _ 107 7/8"
- 2900 mm _ 114 3/16"

Spessore ripiani e staffe
Shelves and brackets thickness

- 38 mm _ 1 1/2"

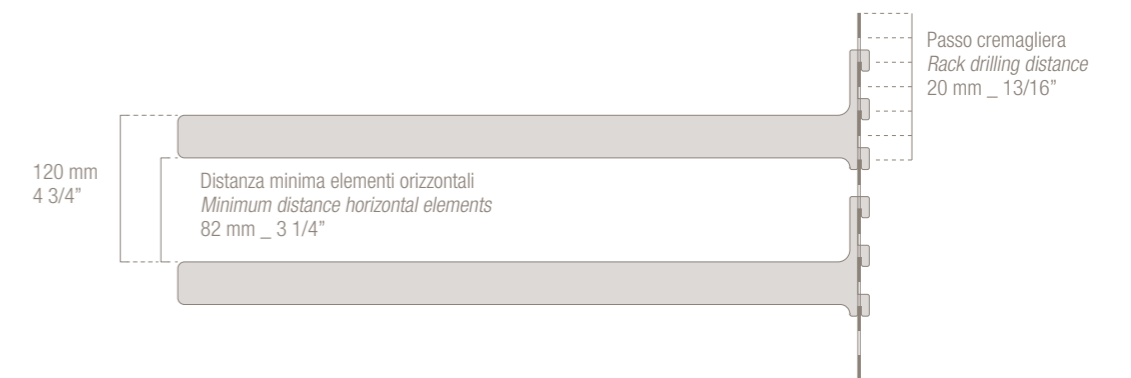

Organizzazione interni _ *Inner unit organization*

ATTREZZATURA _ EQUIPMENT

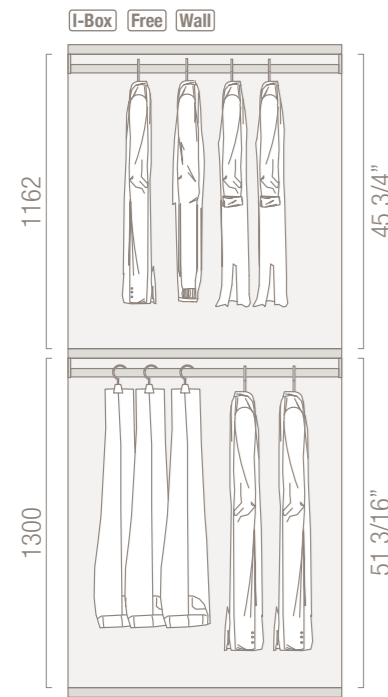

- 1 ripiano _ 1 shelf
- 2 tubi appendiabiti _ 2 hanging rails

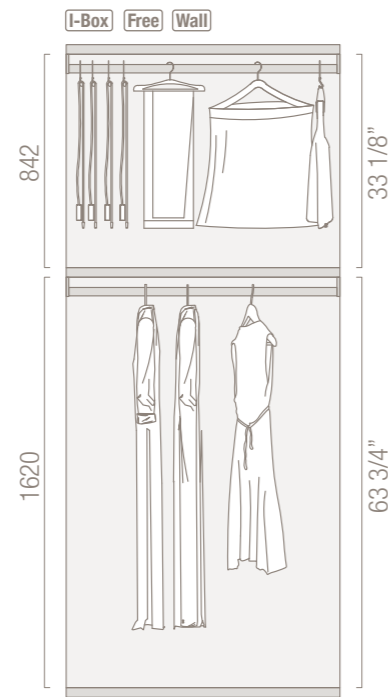

- 1 ripiano _ 1 shelf
- 2 tubi appendiabiti _ 2 hanging rails

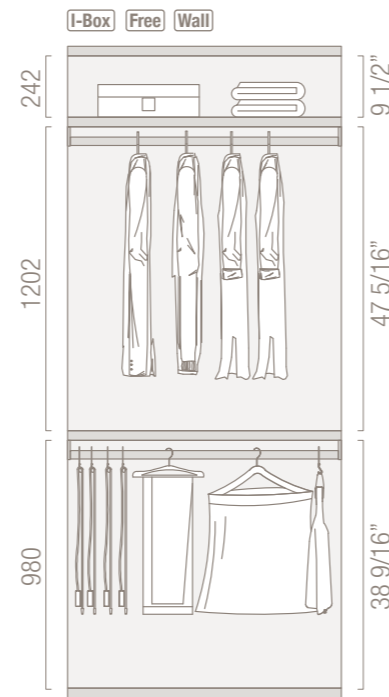

- 2 ripiani _ 2 shelves
- 2 tubi appendiabiti _ 2 hanging rails

ATTREZZATURA _ EQUIPMENT

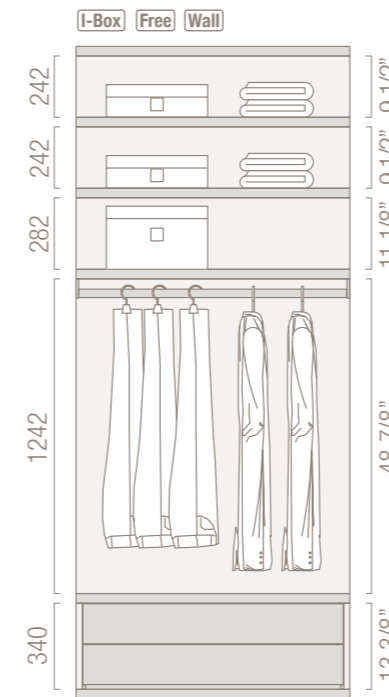

- 3 ripiani _ 3 shelves
- 1 tubo appendiabiti _ 1 hanging rail
- 1 cassettera a terra con 2 cassetti _ 1 chest of 2 drawers

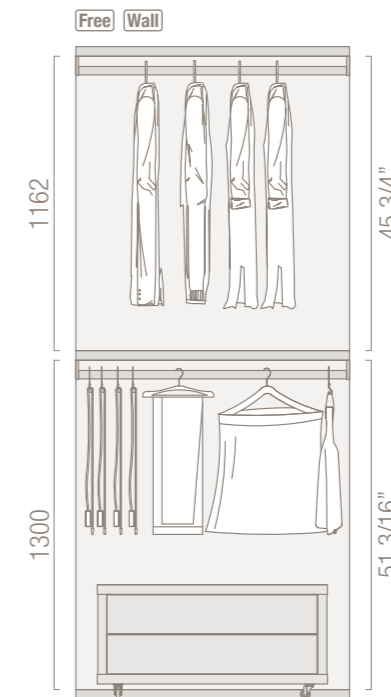

- 1 ripiani _ 1 shelves
- 2 tubi appendiabiti _ 2 hanging rails
- 1 cassettera a terra 2 cassetti _ 1 chest of 2 drawers

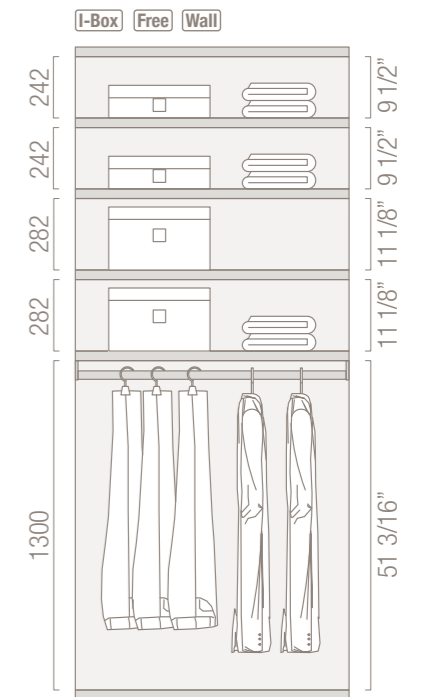

- 4 ripiani _ 4 shelves
- 1 tubo appendiabiti _ 1 hanging rail

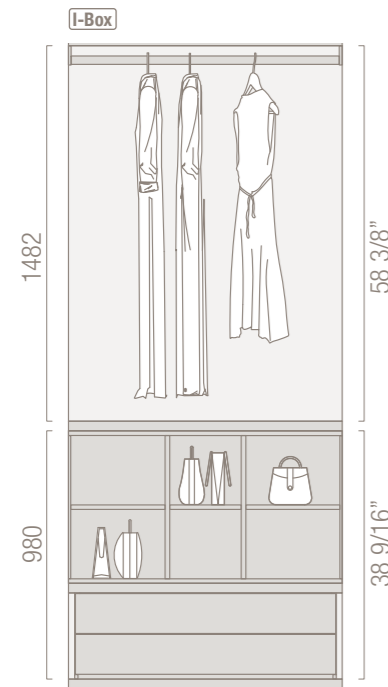

- 1 ripiano _ 1 shelf
- 1 tubo appendiabiti _ 1 hanging rail
- 1 contenitore portaborse _ 1 handbags storage
- 1 cassettera a terra 2 cassetti _ 1 chest of 2 drawers

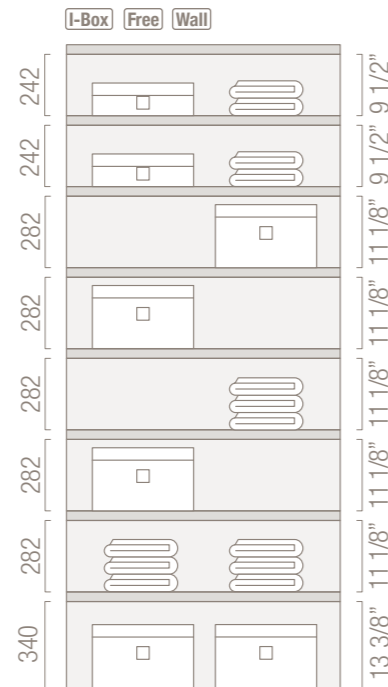

- 7 ripiani _ 7 shelves

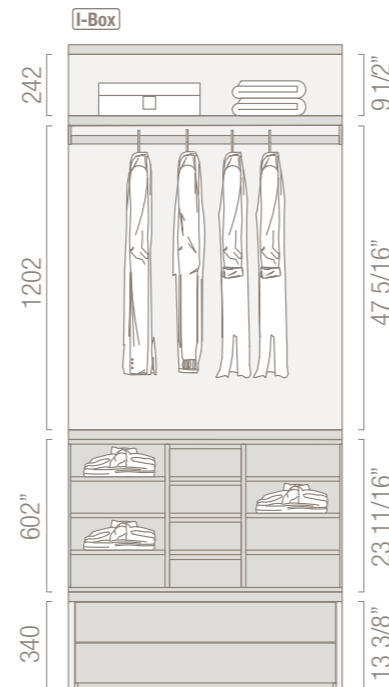

- 2 ripiani _ 2 shelves
- 1 tubo appendiabiti _ 1 hanging rail
- 1 contenitore portacamicie _ 1 shirts storage
- 1 cassettera a terra 2 cassetti _ 1 chest of 2 drawers



- 2 ripiani _ 2 shelves
- 1 tubo appendiabiti _ 1 hanging rail
- 1 cassettera sospesa 2 cassetti _ 1 hanging chest of 2 drawers

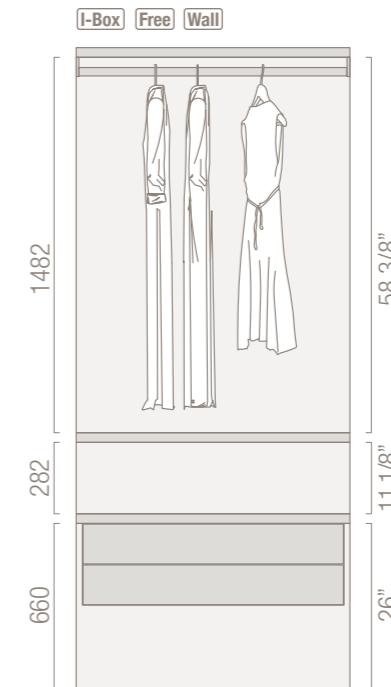

- 1 ripiani _ 1 shelves
- 1 tubo appendiabiti _ 1 hanging rail
- 1 cassettera sospesa 2 cassetti _ 1 hanging chest of 2 drawers

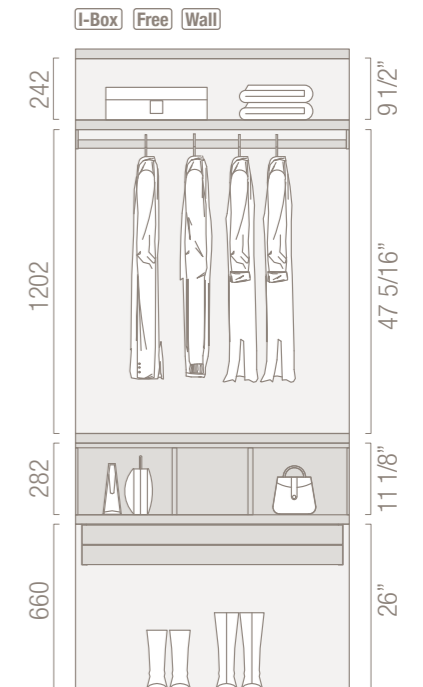

- 2 ripiani _ 2 shelves
- 1 tubo appendiabiti _ 1 hanging rail
- 1 contenitore portaborse _ 1 handbags storage
- 2 vassoi portaoggetti _ 2 trays

Organizzazione interni _ Inner unit organization

ATTREZZATURA _ EQUIPMENT

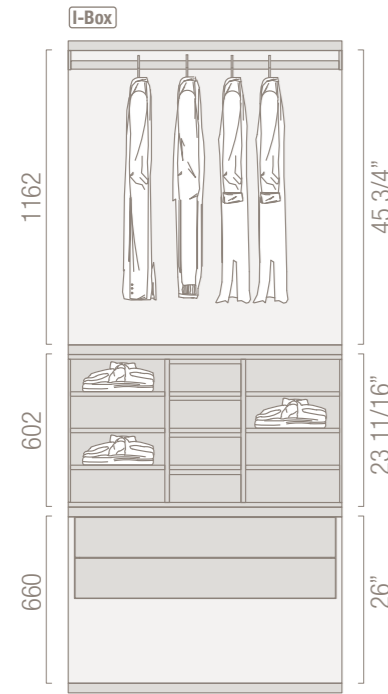

- 1 ripiano _ 1 shelf
- 1 tubo appendiabiti _ 1 hanging rail
- 1 contenitore portacamicie _ 1 shirts storage
- 1 cassetiera sospesa 2 cassetti _ 1 hanging chest of 2 drawers

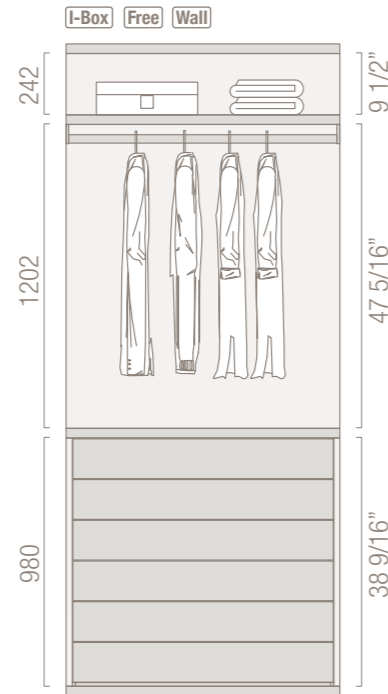

- 1 ripiano _ 1 shelf
- 1 tubo appendiabiti _ 1 hanging rail
- 1 cassetiera a terra 6 cassetti _ 1 chest of 6 drawers

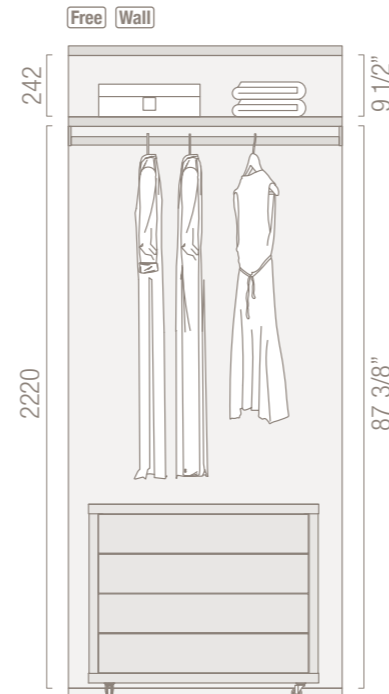

- 1 ripiano _ 1 shelf
- 1 tubo appendiabiti _ 1 hanging rail
- 1 cassetiera su ruote 4 cassetti _ 1 chest with castors and 4 drawers

ATTREZZATURA _ EQUIPMENT

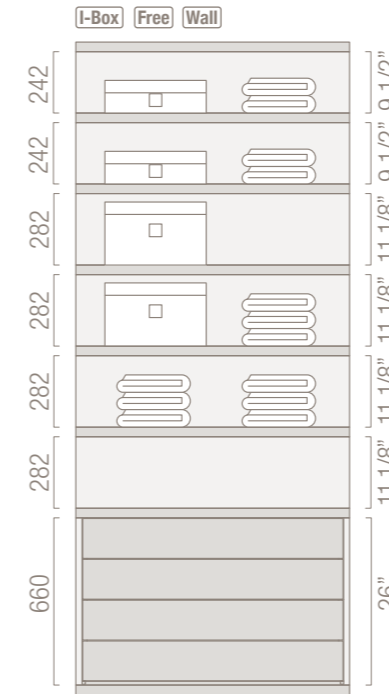

- 5 ripiani _ 5 shelves
- 1 cassetiera a terra 4 cassetti _ 1 chest of 4 drawers

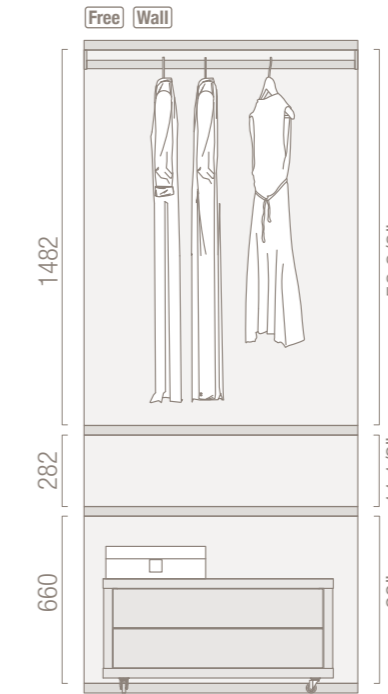

- 2 ripiani _ 2 shelves
- 1 tubo appendiabiti _ 1 hanging rail
- 1 cassetiera su ruote 2 cassetti _ 1 chest with castors and 2 drawers

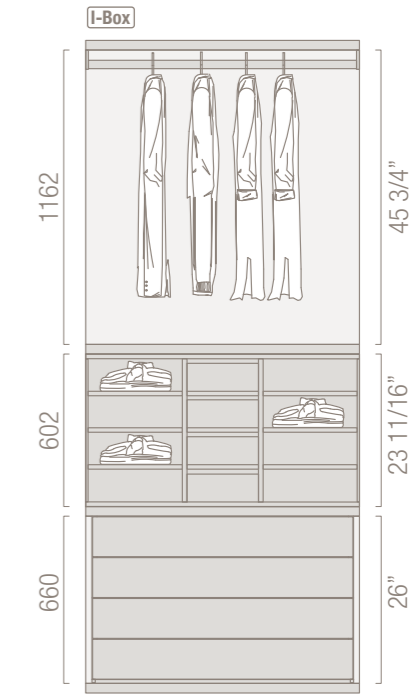

- 1 ripiano _ 1 shelf
- 1 tubo appendiabiti _ 1 hanging rail
- 1 contenitore portacamicie _ 1 shirts storage
- 1 cassetiera a terra 4 cassetti _ 1 chest of 4 drawers

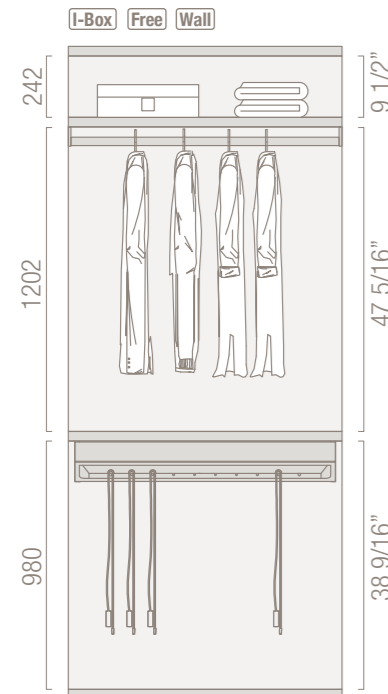

- 1 ripiano _ 1 shelf
- 1 tubo appendiabiti _ 1 hanging rail
- 1 portapantaloni con vassoio portaoggetti _ 1 trousers holder with tray

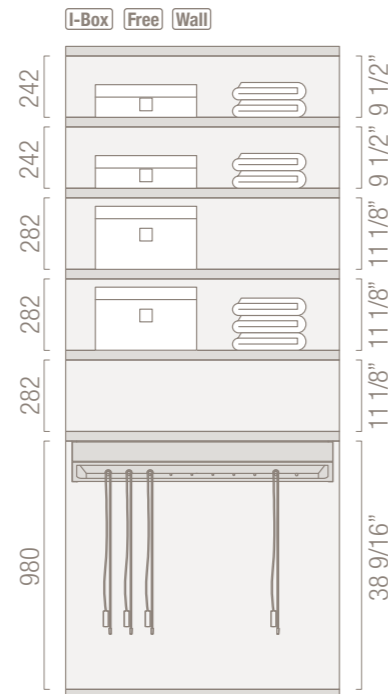

- 4 ripiani _ 4 shelves
- 1 portapantaloni con vassoio portaoggetti _ 1 trousers holder with tray

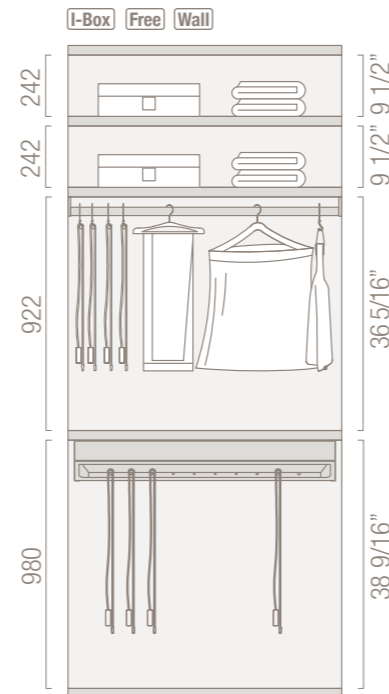

- 2 ripiani _ 2 shelves
- 1 tubo appendiabiti _ 1 hanging rail
- 1 portapantaloni con vassoio portaoggetti _ 1 trousers holder with tray



- 1 ripiano _ 1 shelf
- 1 tubo appendiabiti _ 1 hanging rail
- 1 contenitore portacamicie _ 1 shirts storage
- 1 portapantaloni con vassoio portaoggetti _ 1 trousers holder with tray

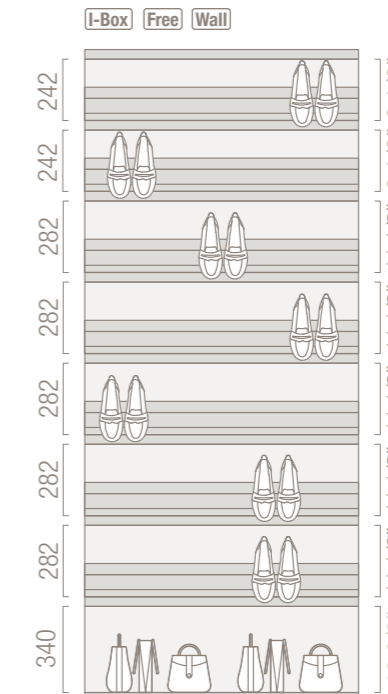

- 7 ripiani portascarpe inclinati _ 7 shoes inclined shelves

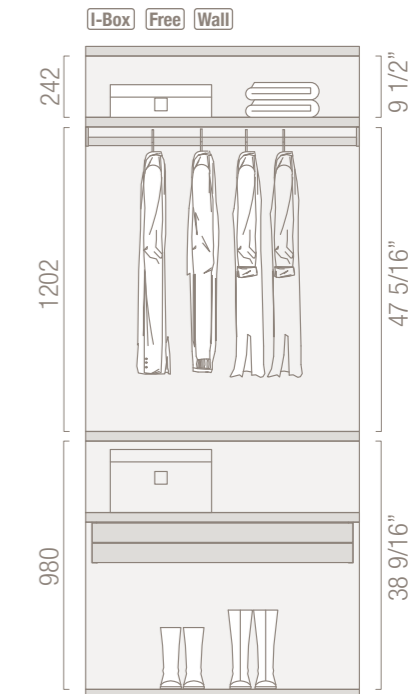

- 3 ripiani _ 3 shelves
- 1 tubo appendiabiti _ 1 hanging rail
- 2 vassoi portaoggetti _ 2 trays

Finitura attrezzatura _ *Equipment finishings*



Finitura attrezzatura _ Equipment finishings



METALLI _ METALS



VETRI _ GLASSES

NB:
** solo vetro V05 Fumè _ glass only Fumè V05



NOBILITATI PELLE _ LEATHER MELAMINES

ELEMENTI IN METALLO _ METAL ELEMENTS

- . Telaio ripiano Frame _ *Frame shelf aluminum part*
- . Telaio ripiano Ecopelle _ *Frame of Eco-leather shelf*
- . Reggi ripiani _ *Shelf supports*
- . Maniglia Applique _ *Applique handle*
- . Maniglia Cardea _ *Cardea handle*
- . Maniglia Flush _ *Flush handle*
- . Divisorio interno in alluminio per cassetti e vassoi _ *Aluminum inner partition for drawers and trays*
- . Elementi Hi-tech: vassoi estraibili, cassetto estraibile, portapantaloni estraibile, portabiancheria estraibile e portascarpe estraibile _ *Hi-tech elements: pull-out trays, pull-out drawers, pull-out trousers holder, pull-out laundry holder and pull-out shoes rack*
- . Vassoio dell'elemento sospeso svuota tasche e portapantaloni _ *Vallet of hanging element pull-out tray and trousers holder*
- . Battitacco scarpiera _ *Heel stopper of inclined shoes rack shelf*
- . Tubo appendiabiti _ *Hanging rail*
- . Cerniere normali _ *Standard hinges*
- . Perno estraibile appendiabiti ripiano legno ed ecopelle _ *Pull-out hook wood and Eco-leather shelves*
- . Vaschetta svuotatasche _ *Vallet tray*
- . Elemento giunzione per schienale L.1402 mm _ *Backpanels shelf joint W. 1402 mm*

ELEMENTI IN VETRO _ GLASS ELEMENTS

- . Vetro ripiano Frame _ *Frame shelf glass part*
- . Ripiano vetro Sp.12mm _ *Glass shelf Th. 12 mm*
- . Ripiani portacamicie e portaborse _ *Shirt and handbags shelves*
- . Fondo vassoio estraibile Hi-tech** _ *Hi-tech pull-out tray bottom part ***
- . Fondo cassetto estraibile Hi-tech** _ *Hi-tech pull-out drawer bottom part ***
- . Frontale cassetto estraibile Hi-tech** _ *Hi-tech pull-out drawer front panel ***
- . Cassetto legno frontale vetro** _ *Wooden drawer with glass front ***

ELEMENTI IN PRIMO FIORE _ PRIMO FIORE ELEMENTS

- . Interno cassetti legno e vassoi legno _ *Wooden drawer and wooden trays internal part*
- . Ripiani portacamicie e portaborse _ *Shirt and handbags shelves*
- . Fondo elemento sospeso svuotatasche _ *hanging elements pull-out tray bottom part*
- . Fondo cassetto estraibile Hi-tech _ *Hi-tech pull-out drawer bottom part*

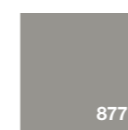

NOBILITATO LISCIO _ SMOOTH MELAMINE

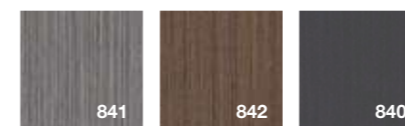

NOBILITATI METALLIZZATI _ METALLIC MELAMINES

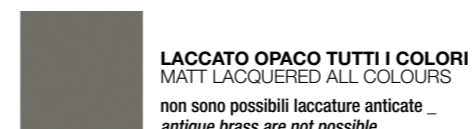

LACCATO OPACO TUTTI I COLORI _
MATT LACQUERED ALL COLOURS
non sono possibili laccature anticcate _
antique brass are not possible

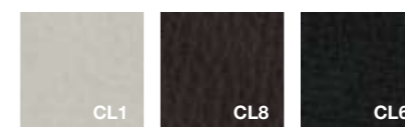

ECOPELLI LAVORATE A291 / A844
EMBOSSED ECO-LEATHERS A291 / A844



ECOPELLI LAVORATE REBEL _
EMBOSSED ECO-LEATHERS REBEL



ECOPELLI LAVORATE VINTAGE _
EMBOSSED ECO-LEATHERS VINTAGE



ECOPELLI LISCE BLOOM
SMOOTH ECO-LEATHERS BLOOM

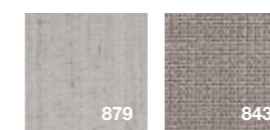

NOBILITATI TESSUTO _ FABRIC MELAMINES

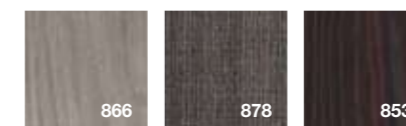

NOBILITATI LEGNO _ WOODEN MELAMINES

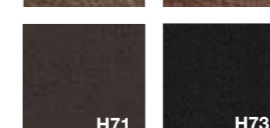
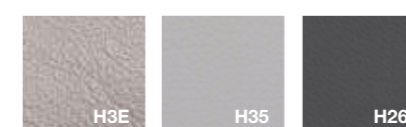
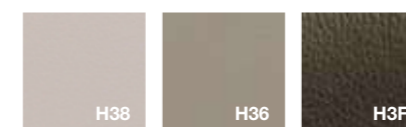

PELLI LISCE _ SMOOTH LEATHERS



PELLI NABUCCATE _ NUBUCK LEATHER

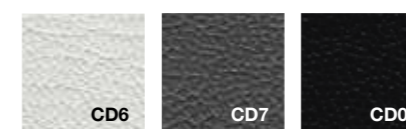
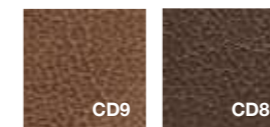

ECOPELLI LISCE OLD _ OLD SMOOTH ECO-LEATHERS

ELEMENTI IN LEGNO _ WOODEN ELEMENTS

- . Ripiani e coperchi legno _ *Wooden shelves and tops*
- . Strutture cassettiere _ *Drawers unit structure*
- . Strutture Elementi sospesi _ *Suspended elem. structure*
- . Strutture Portabiancheria _ *Laundry holder structure*
- . Frontali cassetti, vassoi, elementi sospesi (svuotatasche, portapantaloni) e portabiancheria _ *Drawers front panel, trays, hanging elements front panel (valet tray, trouser hanger) and laundry holder front panel*
- . Scarpiera _ *Shoe-rack trays*
- . Portacamicie, portaborse _ *Shirts, Handbags*

ELEMENTI IN ECOPELLE _ ECO-LEATHER ELEMENTS

- . Ripiani e coperchio ecopelle _ *Eco-leather shelves and tops*
- . Tappetino ecopelle con cucitura per ripiani e coperchio _ *Eco-leather mats with stitching for shelves and tops*
- . Frontali cassetti, vassoi e portabiancheria _ *Drawers front panel, wooden trays front panel and laundry holder front panel*
- . Maniglie Cardea _ *Cardea handle*
- . Tappetino opzionale in ecopelle cassetti, vassoi, vassoi estraibili Hi-tech e cassetti estraibili Hi-tech _ *Eco-leather optional mats for drawers, trays, high-tech pull-out trays and high-tech pull-out drawers*
- . Divisorio interno in ecopelle cassetti, vassoi, elementi sospesi svuotatasche, vassoi estraibili Hi-tech e cassetto estraibili Hi-tech _ *Eco-leather inner partition for drawers, trays, hanging elements pull-out tray, high-tech pull-out trays and high-tech pull-out drawer*
- . Sacca portabiancheria Hi-tech _ *High-tech pull-out laundry holder*

Ripiani _ Shelves



Ripiani _ Shelves

TIPOLOGIE RIPIANI _ TYPOLOGIES OF SHELVES



RIPIANO LEGNO

Ripiano e coperchio cassettiera in particelle di legno. Disponibile in nobilitato e laccato opaco tutti i colori (vedi pag. 358). Sp. 38 mm.

WOODEN SHELF

Chipboard shelves and chest of drawers top. Available in melamine finishings and all matt lacquered colours (see page 358). Th. 1 1/2"

	spalle telaio side frame	spalle legno wood side	profondità depth	340 13 1/3"	profondità depth	546 21 1/2"
I-Box	•	•	•			•
Free						•
Wall			•			•



RIPIANO ECOPELLE

Ripiano e coperchio cassettiera in ecopelle, con telaio in alluminio verniciato metallizzato. Disponibile in ecopelle (vedi pag. 358). Sp. 38 mm.

ECO-LEATHER SHELF

Eco-leather shelves and chest of drawers top. Frame in metallic varnished aluminum. Available eco-leather (see page 358). Th. 1 1/2"

	spalle telaio side frame	spalle legno wood side	profondità depth	340 13 1/3"	profondità depth	546 21 1/2"
I-Box	•	•	•			•
Free						•
Wall			•			•



RIPIANO FRAME

Ripiano in vetro, con telaio in alluminio verniciato metallizzato. Disponibile in vetro trasparente e vetro fumè (vedi pag. 358). Sp. 38 mm.

FRAME SHELF

Glass shelves with frame in metallic varnished aluminum. Available in transparent and fumé glass (see page 358). Th. 1/2"

	spalle telaio side frame	spalle legno wood side	profondità depth	340 13 1/3"	profondità depth	546 21 1/2"
I-Box	•	•				•
Free						•
Wall			•			•

TIPOLOGIE RIPIANI _ TYPOLOGIES OF SHELVES



RIPIANO VETRO

Ripiano e coperchio cassettiera in vetro. Disponibili in vetro trasparente e vetro fumè (vedi pag. 358). Sp. 38 mm.

GLASS SHELF

Glass shelves and chest of drawers top. Available in transparent and fumé glass (see page 358). Th. 1 1/2"

	spalle telaio side frame	spalle legno wood side	profondità depth	340 13 1/3"	profondità depth	546 21 1/2"
I-Box	•	•	•			•
Free						•
Wall						•

N.B.

Per dettaglio finiture nobilitato, laccato opaco, ecopelli e vetri vedi pag. 358-359 _ For finishing details: melamine, matt lacquered, Eco-leather and glass see pages 358-359.

Ripiani _ Shelves

TAPPETINO _ MAT



TAPPETINO ECOPELLE CON CUCITURA

Tappetino ecopelle con supporto, per ripiano e coperchio cassettiera. Disponibile in ecopelle (vedi pag. 358). Sp. 3 mm.

ECO-LEATHER MAT WITH STITCHING

Eco-leather mat for shelves and chest of drawers top. Available in all eco-leather finishings (see page 358). Dimensions: Th. 1/8"

	spalle telaio side frame	spalle legno wood side	profondità depth	340 13 1/3"	profondità depth	546 21 1/2"
I-Box	•	•	•			•
Free						•
Wall			•			•

Ripiani _ Shelves

VARIANTI ECOPELLE _ ECO-LEATHER VARIANTS



VARIANTI ECOPELLE

Disponibile in ecopelle. È possibile caratterizzare gli interni dell'armadio coordinandoli fra loro: il ripiano, il coperchio della cassettera, il frontale del cassetto e la maniglia Cardea possono essere coordinati fra loro.

ECO-LEATHER VARIANTS

Available in eco-leather. It is possible to characterize the interiors of the wardrobe in coordination with each other: shelf, chest of drawer top, drawers front panel, Cardea handle can be coordinate with each other.

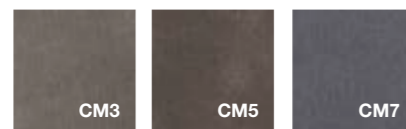

ECOPELLI LAVORATE REBEL
EMBOSSSED ECO-LEATHERS REBEL



ECOPELLI LISCE BLOOM
SMOOTH ECO-LEATHERS BLOOM

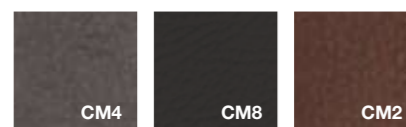
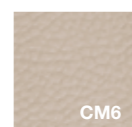

ECOPELLI LAVORATE VINTAGE
EMBOSSSED ECO-LEATHERS VINTAGE

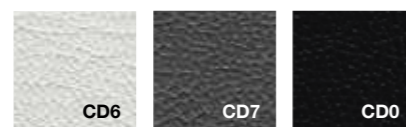
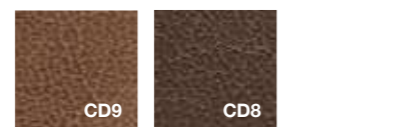

ECOPELLI LISCE OLD
OLD SMOOTH ECO-LEATHERS



ECOPELLI LAVORATE A291 / A844
EMBOSSSED ECO-LEATHERS A291 / A844

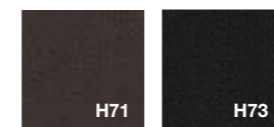
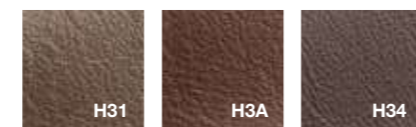
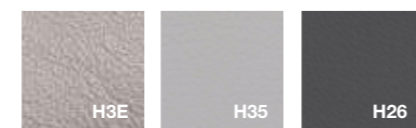
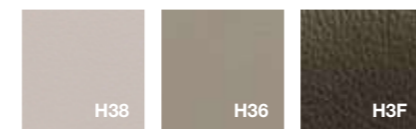

PELLI LISCE _ SMOOTH LEATHERS



PELLI NABUCCATE _ NUBUCK LEATHER



Cassettiere _ *Chest of drawers*



Cassettiere _ Chest of drawers

TIPOLOGIE STRUTTURE _ TYPOLOGIES STRUCTURE

- A. Strutture a terra con top legno o ecopelle per cassetti a vassoi _
Standing structures with wooden or eco-leather top for drawers and trays
- B. Strutture a terra con vano a giorno e top in vetro per cassetti e vassoi _
Standing struc. with glass top and open compartment for drawers and trays
- C. Strutture sospese con top legno o ecopelle per cassetti e vassoi _
Hanging structures with wooden or eco-leather top for drawers and trays

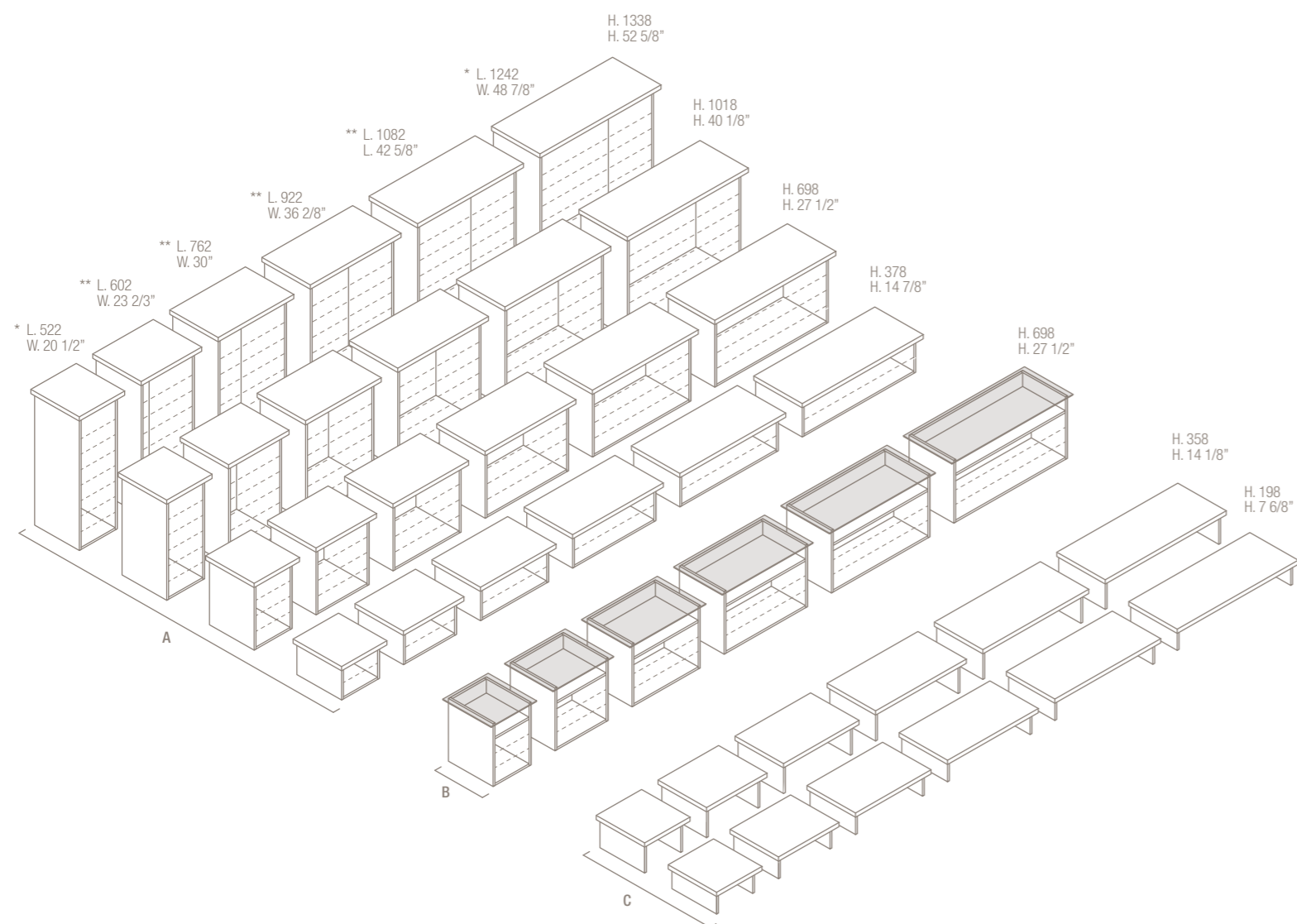

I-Box	Free	Wall
A	•	•*
B	•	
C	•	•
D	•	•
E	•	

Solo per gruppo A _ Only for group A

* Larghezze non disponibile per Free e Wall
Widths not available for "Free" and "Wall"

** Per la larghezza di Free e Wall considerare 3 mm in più
"Free" and "Wall" width are 3 mm (1/8") larger

Tutte le misure sono intese con coperchio incluso
All sizes are intended with top cover included

Coperchio Legno o ecopelle _ wooden or eco-leather top:
spessore 38 mm _ Th. 1 1/2"

Coperchio vetro _ glass: spessore 12 mm _ Th. 1/2".

TIPOLOGIE STRUTTURE _ TYPOLOGIES STRUCTURE

- D. Strutture su ruote con top legno o ecopelle per cassetti e vassoi _
Structures with castors with wooden or eco-leather top for drawers and trays
- E. Strutture a terra top legno o ecopelle per cassetti a vassoi _
Standing structures with wooden or eco-leather top for drawers and trays

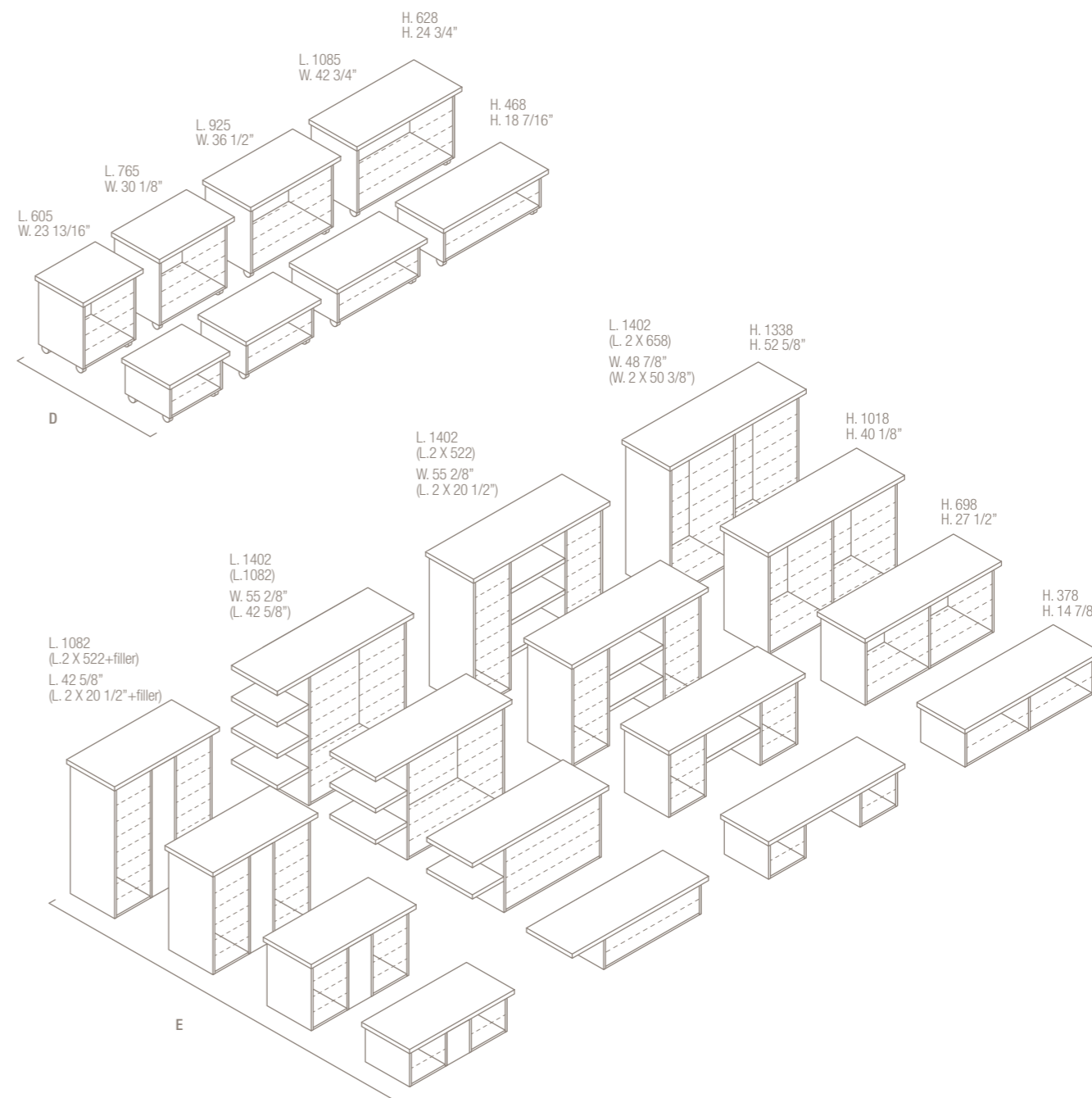

Cassettiere _ Chest of drawers

TIPOLOGIE STRUTTURE _ TYPOLOGIES STRUCTURE



STRUTTURE A TERRA TOP LEGNO O ECOPELLE PER CASSETTI E VASSOI

Cassettiera a terra con coperchio Sp. 38 mm in legno o ecopelle in tutte le finiture. Struttura in nobilitato o laccato opaco tutti colori. Disponibile in 6 larghezze e 4 altezze (vedi pag 364-365). Non sono disponibili riduzioni a misura.

STANDING STRUCTURES WOODEN OR ECO-LEATHER TOP FOR DRAWERS AND TRAYS

Chest of drawers with wooden or Eco-leather top (Th. 1 1/2") in all finishings. Structures in melamine finishings or all matt lacquered. Available in 6 widths and 4 heights (see page 364-365). No reductions are available to size.

	spalle telaio side frame	spalle legno wood side	profondità 340 depth 13 1/3"	profondità 546 depth 21 1/2"
I-Box	•	•	•	•
Free				•
Wall			•	



STRUTTURE SOSPESE TOP LEGNO O ECOPELLE PER CASSETTI E VASSOI

Cassettiera sospesa con coperchio Sp. 38 mm in legno o ecopelle in tutte le finiture. Struttura in nobilitato o laccato opaco tutti colori. Disponibile in 5 larghezze e 2 altezze (vedi pag 364-365). Non sono disponibili riduzioni a misura.

HANGING STRUCTURES WOODEN OR ECO-LEATHER TOP FOR DRAWERS AND TRAYS

Hanging chest of drawers with wooden or Eco-leather top (Th. 1 1/2") in all finishings. Structures in melamine finishings or all matt lacquered colours. Available in 5 widths and 2 heights (see page 364-365). No reductions are available to size.

	spalle telaio side frame	spalle legno wood side	profondità 340 depth 13 1/3"	profondità 546 depth 21 1/2"
I-Box	•	•	•	•
Free				•
Wall			•	

TIPOLOGIE STRUTTURE _ TYPOLOGIES STRUCTURE



STRUTTURA A TERRA CON VANO A GIORNO E TOP IN VETRO PER CASSETTI E VASSOI

Cassettiera a terra con coperchio Sp. 12 mm in vetro trasparente o fumè, dotata di vano a giorno. Struttura in nobilitato o laccato opaco tutti colori. Disponibile in 5 larghezze e 1 altezza (vedi pag 364-365). Non sono disponibili riduzioni a misura.

STANDING STRUCTURES GLASS TOP AND OPEN COMPARTMENT FOR DRAWERS AND TRAYS

Chest of drawers with top in fumè or transparent glass (Th. 1/2") and equipped with a open compartment. Structures in melamine finishings or all matt lacquered colours. Available in 5 widths and 2 heights (see page 364-365). No reductions are available to size.

	spalle telaio side frame	spalle legno wood side	profondità 340 depth 13 1/3"	profondità 546 depth 21 1/2"
I-Box	•	•	•	•
Free				•
Wall				



STRUTTURE SU RUOTE CON TOP LEGNO O ECOPELLE PER CASSETTI E VASSOI

Cassettiera su ruote con coperchio Sp. 38 mm in legno o ecopelle in tutte le finiture. Struttura in nobilitato o laccato opaco tutti colori. Disponibile in 4 larghezze e 2 altezze (vedi pag 364-365). Non sono disponibili riduzioni a misura.

STRUCTURES WITH CASTORS WITH WOODEN OR ECO-LEATHER TOP FOR DRAWERS AND TRAYS

Chest of drawers with castors and wooden or eco-leather top (Th. 1 1/2") in all finishings. Structures in melamine finishings or all matt lacquered colours. Available in 4 widths and 2 heights (see page 364-365). No reductions are available to size.

	spalle telaio side frame	spalle legno wood side	profondità 340 depth 13 1/3"	profondità 546 depth 21 1/2"
I-Box				•
Free				•
Wall			•	•

Focus On

CASSETTIERA NELL'ANGOLO CON ANTE _ CHEST OF DRAWERS IN THE CORNER WITH DOOR

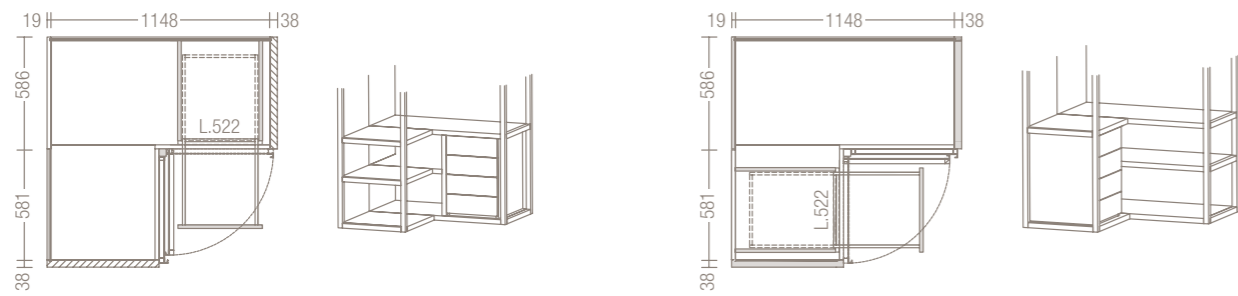

CASSETTIERA NELL'ANGOLO SENZA ANTE _ CHEST OF DRAWERS IN THE CORNER WITHOUT DOOR

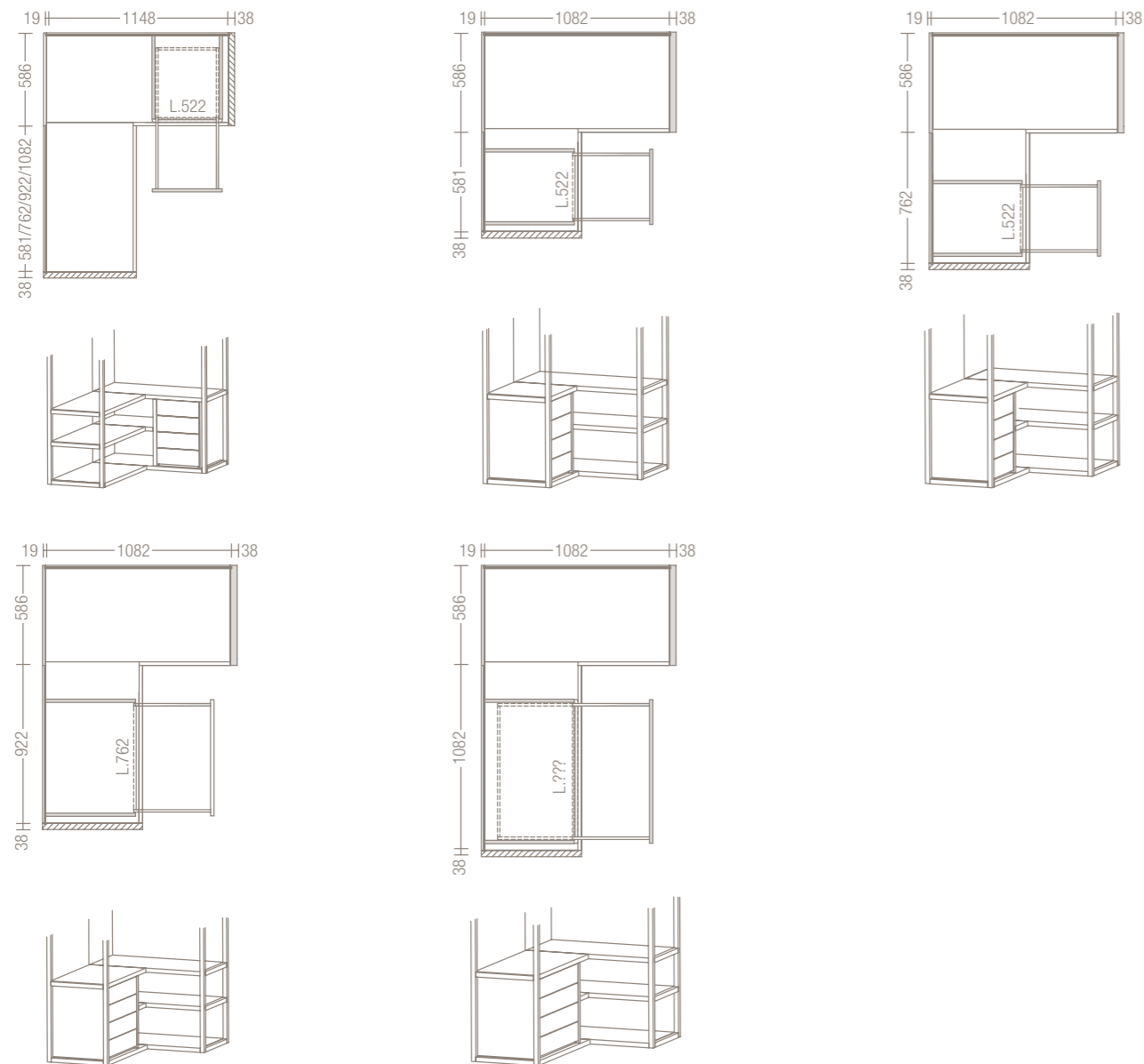

Cassettiere _ Chest of drawers

TIPOLOGIE CASSETTI E VASSOI _ STRUCTURES TYPOLOGIES FOR DRAWERS AND TRAYS

A. Cassetti in legno alti _ High wooden drawers

B. Cassetti in legno bassi _ Low wooden drawers

C. Cassetti in legno, frontale in vetro _ Wooden drawers, glass front

D. Vassoio estraibile _ Pull-out tray

E. Vassoio portascarpe estraibile _ Pull-out shoe rack tray

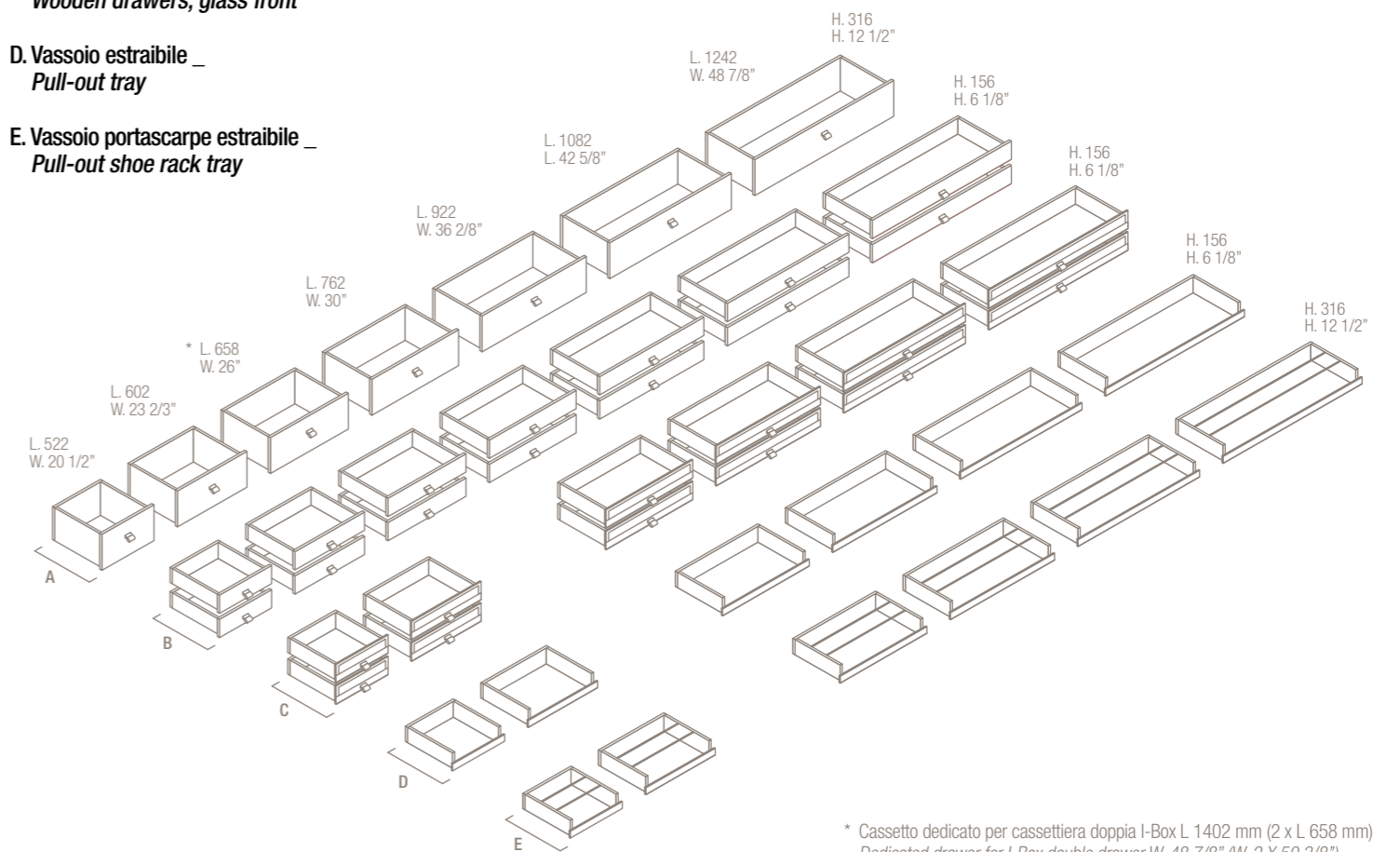

* Cassetto dedicato per cassetiera doppia I-Box L 1402 mm (2 x L 658 mm)
Dedicated drawer for I-Box double drawer W. 48 7/8" (W. 2 X 50 3/8")

MANIGLIE _ HANDLES

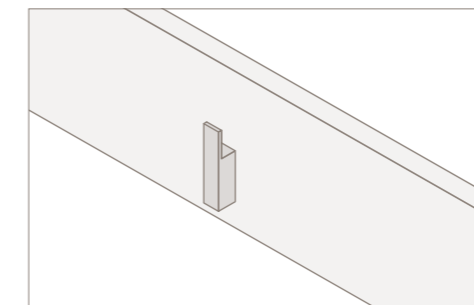

Applique
Disponibile per _ Available for: A, B, C

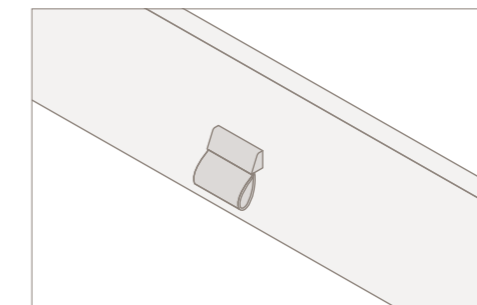

Cardea
Disponibile per _ Available for: A, B, C, D, E

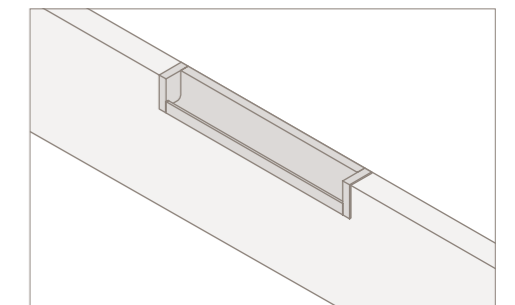

Flush
Disponibile per _ Available for: A, B



Cassettiere _ Chest of drawers

TIPOLOGIE CASSETTI FRONTALE LEGNO _ WOODEN DRAWERS TYPOLOGIES



CASSETTO LEGNO - MANIGLIA APPLIQUE

Cassetto ad estrazione totale ammortizzata, disponibile per tutte le cassettiere a terra e sospese.
 Finiture: Frontale in nobilitato, laccato opaco tutti i colori o ecopelle. Maniglia verniciata Canna di Fucile.
 Interno cassetto nobilitato Primo Fiore. Dimensioni: H. 160 mm e 320 mm.

WOODEN DRAWER - APPLIQUE HANDLE

Drawer with full extraction and soft closing mechanism, available for both standing and hanging chest of drawers.
 Finishing: door in melamine, all finishings matt lacquered colours or eco-leather colours. Handle varnished Gunmetal.
 Interior in Primo Fiore melamine finishing. Dimensions: H. 6 2/8" and 12 5/8".



CASSETTO LEGNO - MANIGLIA CARDEA

Cassetto ad estrazione totale ammortizzata, disponibile per tutte le cassettiere a terra e sospese. Finiture: Frontale in nobilitato, laccato opaco tutti i colori o ecopelle. Maniglia verniciata Canna di Fucile e in ecopelle. Interno cassetto nobilitato primo fiore. Dimensioni: H. 160 mm e 320 mm.

WOODEN DRAWER - CARDEA HANDLE

Drawer with full extraction and soft closing mechanism, available for both standing and hanging chest of drawers.
 Finishing: door in melamine, all finishings matt lacquered colours, eco-leather colours. Handle varnished Gunmetal and eco-leather colours. Interior in Primo Fiore melamine finishing. Dimensions: H. 6 2/8" and 12 5/8".



CASSETTO LEGNO - MANIGLIA FLUSH

Cassetto ad estrazione totale ammortizzata, disponibile per tutte le cassettiere a terra e sospese. Finiture: Frontale in nobilitato, laccato opaco tutti i colori. Maniglia verniciata Canna di Fucile. Interno cassetto nobilitato Primo Fiore. Dimensioni: H. 160 mm e 320 mm.

WOODEN DRAWER - FLUSH HANDLE

Drawer with full extraction and soft closing mechanism, available for both standing and hanging chest of drawers.
 Finishing: door in melamine, all finishings matt lacquered colours. Handle varnished Gunmetal. Interior in Primo Fiore melamine finishing. Dimensions: H. 6 2/8" and 12 5/8".

Cassettiere _ Chest of drawers

TIPOLOGIE CASSETTI FRONTALE VETRO _ GLASS DRAWERS TYPOLOGIES



CASSETTO LEGNO FRONTALE VETRO - MANIGLIA APPLIQUE

Cassetto ad estrazione totale ammortizzata, disponibile per tutte le cassettiere a terra e sospese. Finiture: Parte frontale legno in nobilitato, laccato opaco tutti i colori o ecopelle. Parte in vetro, in vetro fumè. Maniglia verniciata Canna di Fucile. Interno cassetto nobilitato Primo Fiore. Dimensioni: H. 160 mm e 320 mm.

WOODEN DRAWER WITH GLASS FRONT - APPLIQUE HANDLE

Drawer with full extraction and soft closing mechanism, available for both standing and hanging chest of drawers. Finishing: wooden door part in melamine, all finishings matt lacquered colours or eco-leather colours. Glass door part in fumè glass. Handle varnished Gunmetal. Interior in Primo Fiore melamine finishing. Dimensions: H. 6 2/8" and 12 5/8".



CASSETTO LEGNO FRONTALE VETRO - MANIGLIA CARDEA

Cassetto ad estrazione totale ammortizzata, disponibile per tutte le cassettiere a terra e sospese. Finiture: Parte frontale legno in nobilitato, laccato opaco tutti i colori o ecopelle. Parte in vetro, in vetro fumè. Maniglia verniciata Canna di Fucile e ecopelle. Interno cassetto nobilitato Primo Fiore. Dimensioni: H. 160 mm e 320 mm.

WOODEN DRAWER WITH GLASS FRONT - CARDEA HANDLE

Drawer with full extraction and soft closing mechanism, available for both standing and hanging chest of drawers. Finishing: wooden door part in melamine, all finishings matt lacquered colours or eco-leather colours. Glass door part fumè glass. Handle varnished Gunmetal and eco-leather colours. Interior in Primo Fiore melamine finishing. Dimensions: H. 6 2/8" and 12 5/8".

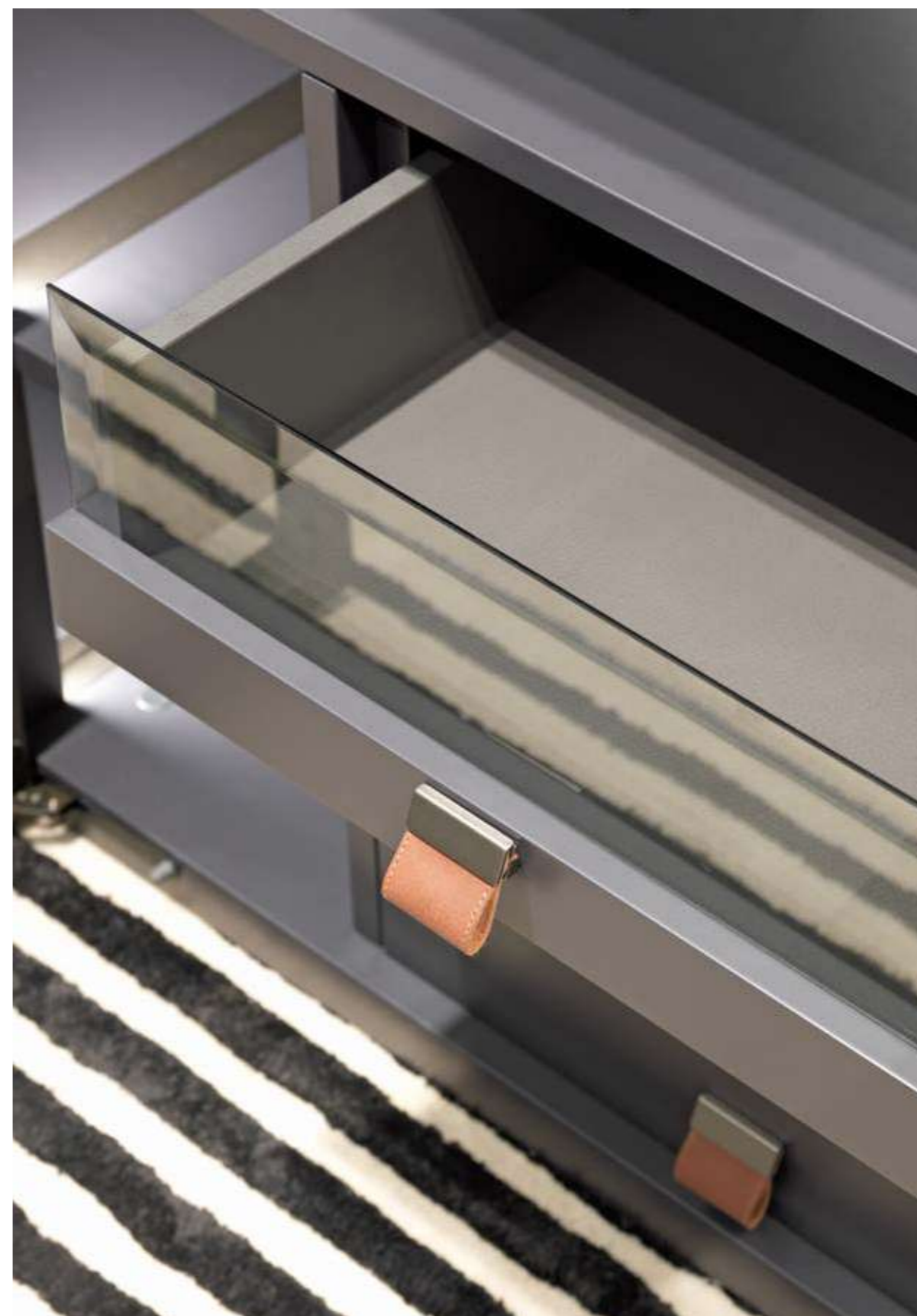



Cassettiere _ Chest of drawers

TIPOLOGIE VASSOI _ TRAYS TYPOLOGIES



VASSOIO LEGNO

Vassoio ad estrazione totale ammortizzata disponibile per tutte le cassettiere a terra e sospese. Finiture: parte frontale in legno in nobilitato, laccato opaco tutti i colori o ecopelle. Interno vassoio nobilitato Primo Fiore. Disponibile senza maniglia o con maniglia APPLIQUE o CARDEA. Dimensioni: H.160 mm.

WOODEN TRAY

Trays with full extraction and soft-closing mechanism available for both standing and hanging chests of drawers. Finisings: wooden door part in melamine, all matt lacquered colours or eco-leather colours. Interior in Primo Fiore melamine finishing. Available without handle or with APPLIQUE handle or CARDEA handle. Dimensions: H. 6 2/8".



VASSOIO LEGNO PORTASCARPE

Vassoio con tondini verniciati Canna di Fucile ad estrazione totale ammortizzata disponibile per tutte le cassettiere a terra e sospese. Finiture: parte frontale in legno in nobilitato, laccato opaco tutti i colori o ecopelle. Interno vassoio nobilitato Primo Fiore. Disponibile senza maniglia o con maniglia APPLIQUE o CARDEA. Dimensioni: H.160 mm.

N.B. Il vassoio portascarpe necessita di uno spazio nella cassetta pari a un cassetto legno H. 320 mm.

WOODEN SHOES TRAY

Tray with Gunmetal varnished rods with full extraction and soft-closing mechanism available for both standing and hanging chests of drawers. Finisings: wooden door part in melamine, all matt lacquered colours or eco-leather colours. Interior in Primo Fiore melamine finishing. Available without handle or with APPLIQUE handle or CARDEA handle. Dimensions: H. 6 2/8".

Note: The shoes tray occupies a space in the chest of drawers equal to a wooden drawer H. 12 5/8".

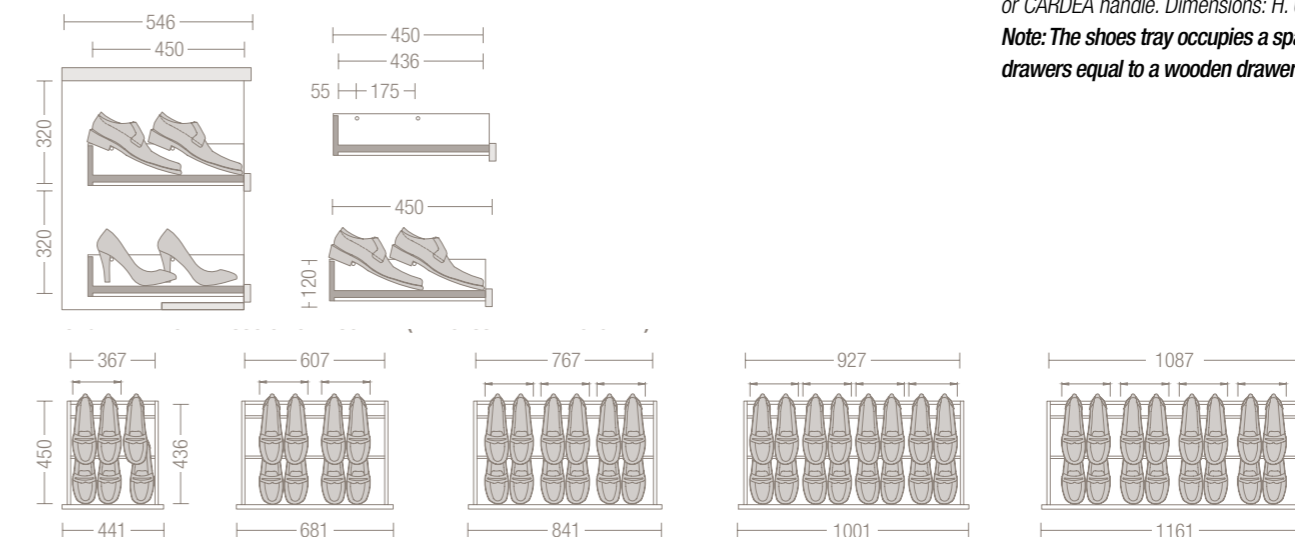

Cassettiere _ Chest of drawers

CAPIENZA CASSETTI E VASSOI _ DRAWERS AND TRAYS CAPACITY

Cassetto L. 441 mm _ P. 450 e P. 280 mm

Interno utile L. 367 mm _ P. 436 e P. 266 mm

Drawer W. 17 3/8" _ D. 17 6/8" and 11"

Inner space W. 14 1/2" _ D. 17 1/8" and 10 1/2"

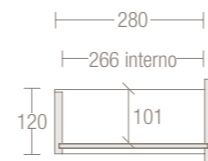
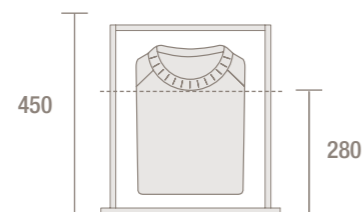

Cassetto L. 681 mm _ P. 450 e P. 280 mm

Interno utile L. 607 mm _ P. 436 e P. 266 mm

Drawer W. 26 6/8" _ D. 17 6/8" and 11"

Inner space W. 23 7/8" _ D. 17 1/8" and 10 1/2"

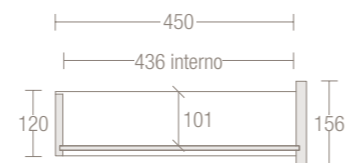
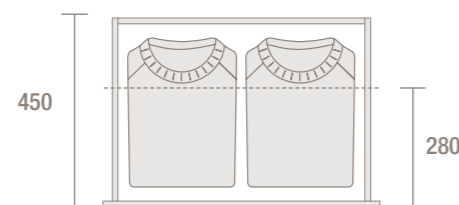

Cassetto L. 841 mm _ P. 450 e P. 280 mm

Interno utile L. 767 mm _ P. 436 e P. 266 mm

Drawer W. 33 1/8" _ D. 17 6/8" and 11"

Inner space W. 30 2/8" _ D. 17 1/8" and 10 1/2"

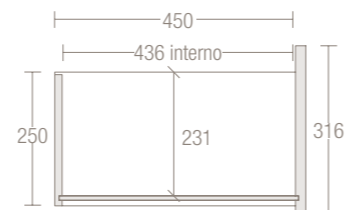
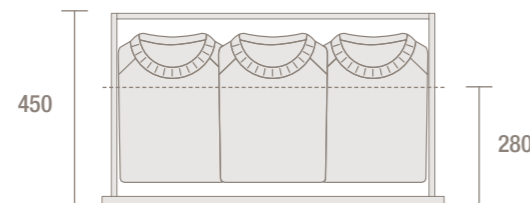

Cassetto L. 1001 mm _ P. 450 e P. 280 mm

Interno utile L. 927 mm _ P. 436 e P. 266 mm

Drawer W. 39 3/8" _ D. 17 6/8" and 11"

Inner space W. 36 1/2" _ D. 17 1/8" and 10 1/2"

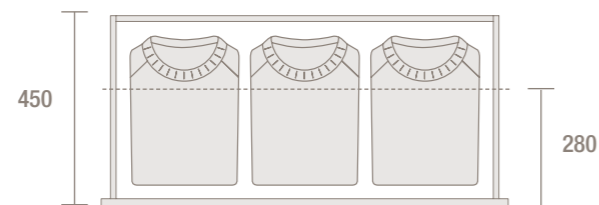

Cassetto L. 1161 mm _ P. 450 e P. 280 mm

Interno utile L. 1087 mm _ P. 436 e P. 266 mm

Drawer W. 45 6/8" _ D. 17 6/8" and 11"

Inner space W. 42 6/8" _ D. 17 1/8" and 10 1/2"

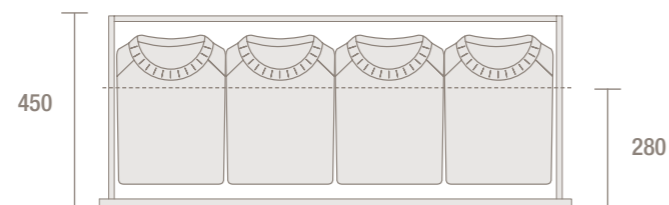

Cassettiere _ Chest of drawers

ACCESSORI PER CASSETTI E VASSOI _ EQUIPMENT FOR DRAWERS AND TRAYS

**DIVISORIO INTERNO IN ALLUMINIO PER CASSETTI E VASSOI**

Divisorio in alluminio verniciato Canna di Fucile inseribile in cassetti e vassoi, consigliato per cinture e cravatte. Dimensioni: L.522 (9 vani), L.658 (12 vani), L.762 (12 vani), L.922 (15 vani), L.1082 (21 vani) e L.1242 (24 vani).

ALUMINUM INNER PARTITION FOR DRAWERS AND TRAYS

Partition in gun metal varnished aluminum for drawers and trays, recommended for belts and ties. Dimensions: W.20 1/2" (9 compartments), W.25 7/8" (12 compartments), W.30" (12 compartments), W.36 2/8" (15 compartments), W.42 5/8" (21 compartments) e W.48 7/8" (24 compartments).

**TAPPETINO OPZIONALE IN ECOPELLE PER CASSETTI E VASSOI**

Tappetino senza cuciture per fondo cassetti o vassoi. Disponibile in tutte le finiture (vedi pag. 358).

ECO-LEATHER OPTIONAL MAT FOR DRAWERS AND TRAYS

Mat without stitching for bottom drawers and trays. Available in all finishings (see page 358).

ACCESSORI PER CASSETTI E VASSOI _ EQUIPMENT FOR DRAWERS AND TRAYS

**DIVISORIO INTERNO IN ECOPELLE PER CASSETTI E VASSOI**

Tappetino con cuciture e divisori in ecopelle per fondo cassetti e vassoi. Disponibile in tutte le finiture. Dimensioni: L.522, L.658, L.762, L.922, L.1082 e L.1242.

ECO-LEATHER INNER PARTITION FOR DRAWERS AND TRAYS

Mat with stitching and eco-leather inner partition for bottom drawers and trays. Available in all finishings. Dimensions: W.20 1/2", W.25 7/8", W.30", W.36 2/8", W.42 5/8" e W.48 7/8".

**PORTA OROLOGI / ORECCHINI / ANELLI**

Gli accessori porta orologi / orecchini / anelli possono essere inseriti nei cassetti e nei vassoi, anche in presenza del divisorio interno in ecopelle.

Per proposta accessori pag. 386-387.

WATCHES / EARRINGS / RINGS HANGER

Watches / earrings / rings hangers can be inserted in the drawers and trays, even in the presence of eco-leather inner partition.

For equipment options pages 386-387.



Cassettiere _ Chest of drawers

PROPOSTE PORTA OGGETTI PER CASSETTI E VASSOI _ PROPOSALS FOR OBJECTS FOR DRAWERS AND TRAYS

Accessori _ Equipments

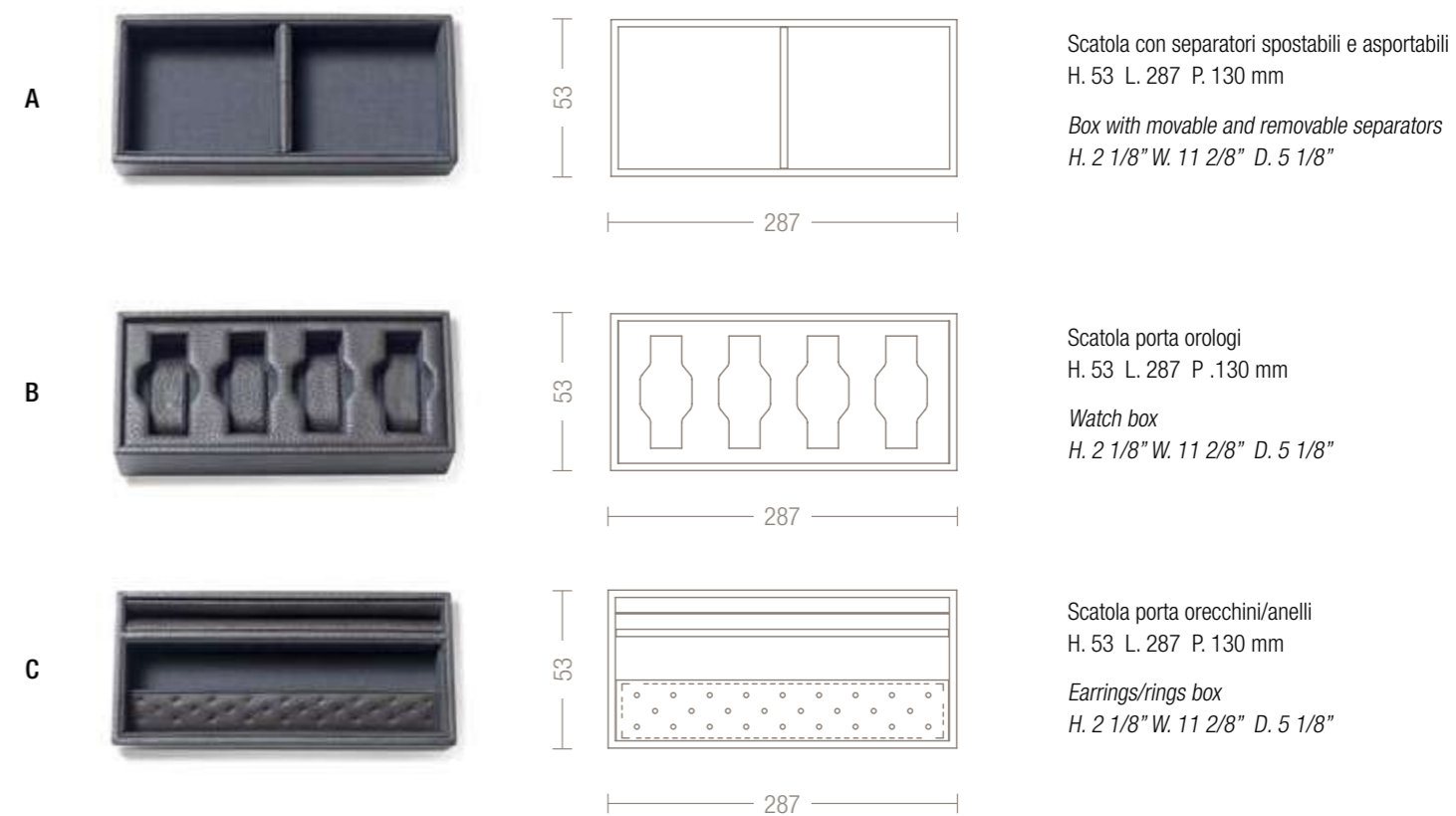

Cassettiere _ Chest of drawers

PROPOSTE PER CASSETTIERE CON P. 586 MM _ OPTIONS FOR CHESTS OF DRAWERS D. 23 1/8"

Proposta 1A _ Option 1A

- n°1 porta orologi
- n°1 porta orecchini/anelli
- n°1 scatola con separatori
- n°1 watch box
- n°1 earrings/rings box
- n°1 box with separators

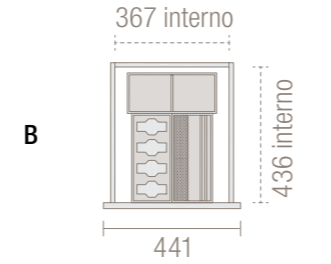
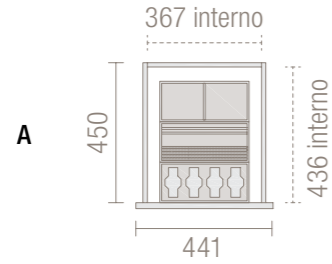

Proposta 2A _ Option 2A

- n°2 porta orologi
- n°2 porta orecchini/anelli
- n°2 scatola con separatori
- n°2 watch box
- n°2 earrings/rings box
- n°2 box with separators

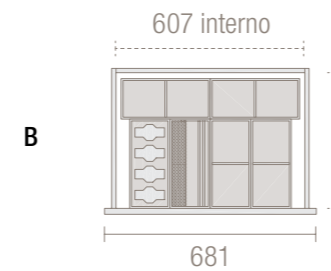
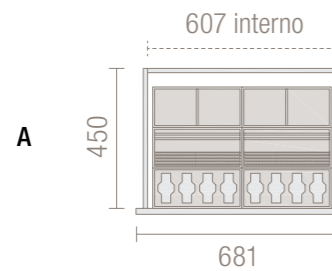

Proposta 3A _ Option 3A

- n°2 porta orologi
- n°2 porta orecchini/anelli
- n°3 scatola con separatori
- n°2 watch box
- n°2 earrings/rings box
- n°3 box with separators

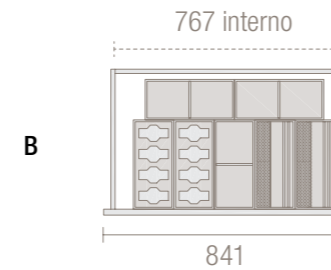
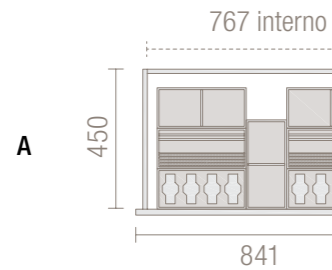

Proposta 4A _ Option 4A

- n°3 porta orologi
- n°3 porta orecchini/anelli
- n°3 scatola con separatori
- n°3 watch box
- n°3 earrings/rings box
- n°3 box with separators

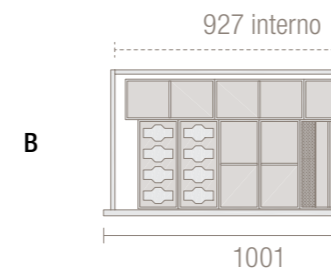
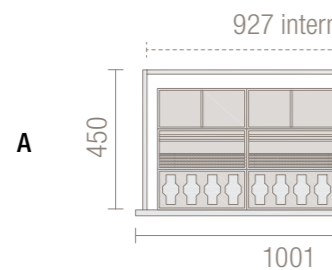

Proposta 5A _ Option 5A

- n°3 porta orologi
- n°3 porta orecchini/anelli
- n°4 scatola con separatori
- n°3 watch box
- n°3 earrings/rings box
- n°4 box with separators

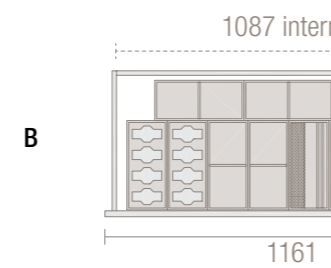
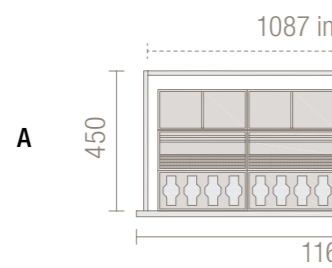

PROPOSTE PER CASSETTIERE CON P. 346 MM _ OPTIONS FOR CHESTS OF DRAWERS D. 13 5/8"

Proposta 1A _ Option 1A

- n°1 porta orologi
- n°1 porta orecchini/anelli
- n°1 scatola con separatori
- n°1 watch box
- n°1 earrings/rings box
- n°1 box with separators

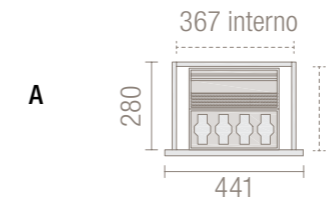

Proposta 2A _ Option 2A

- n°2 porta orologi
- n°2 porta orecchini/anelli
- n°2 scatola con separatori
- n°2 watch box
- n°2 earrings/rings box
- n°2 box with separators

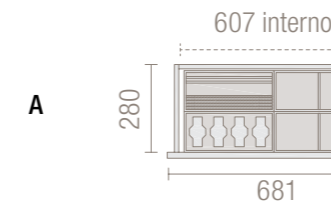

Proposta 3A _ Option 3A

- n°2 porta orologi
- n°2 porta orecchini/anelli
- n°3 scatola con separatori
- n°2 watch box
- n°2 earrings/rings box
- n°3 box with separators

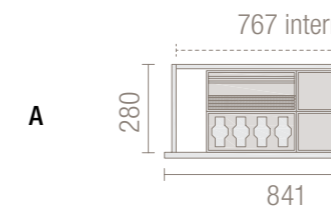

Proposta 4A _ Option 4A

- n°3 porta orologi
- n°3 porta orecchini/anelli
- n°3 scatola con separatori
- n°3 watch box
- n°3 earrings/rings box
- n°3 box with separators

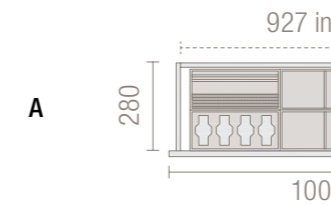

Proposta 5A _ Option 5A

- n°3 porta orologi
- n°3 porta orecchini/anelli
- n°4 scatola con separatori
- n°3 watch box
- n°3 earrings/rings box
- n°4 box with separators

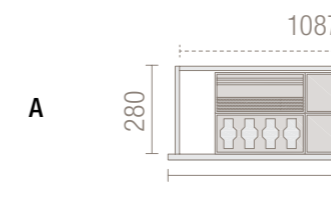

Elementi sospesi _ *Hanging elements*





Elementi sospesi _ *Hanging elements*

TIPOLOGIE ELEMENTI SOSPESI_ *HANGING ELEMENTS TYPOLOGIES*

A. Vassoio svuotatasche e portapantaloni sospesi _
Tray and trouser holder

B. Doppio vassoio svuotatasche _
Double tray

C. Portapantaloni sospesi _
Trouser holder

D. Vassoio svuotatasche _
Tray

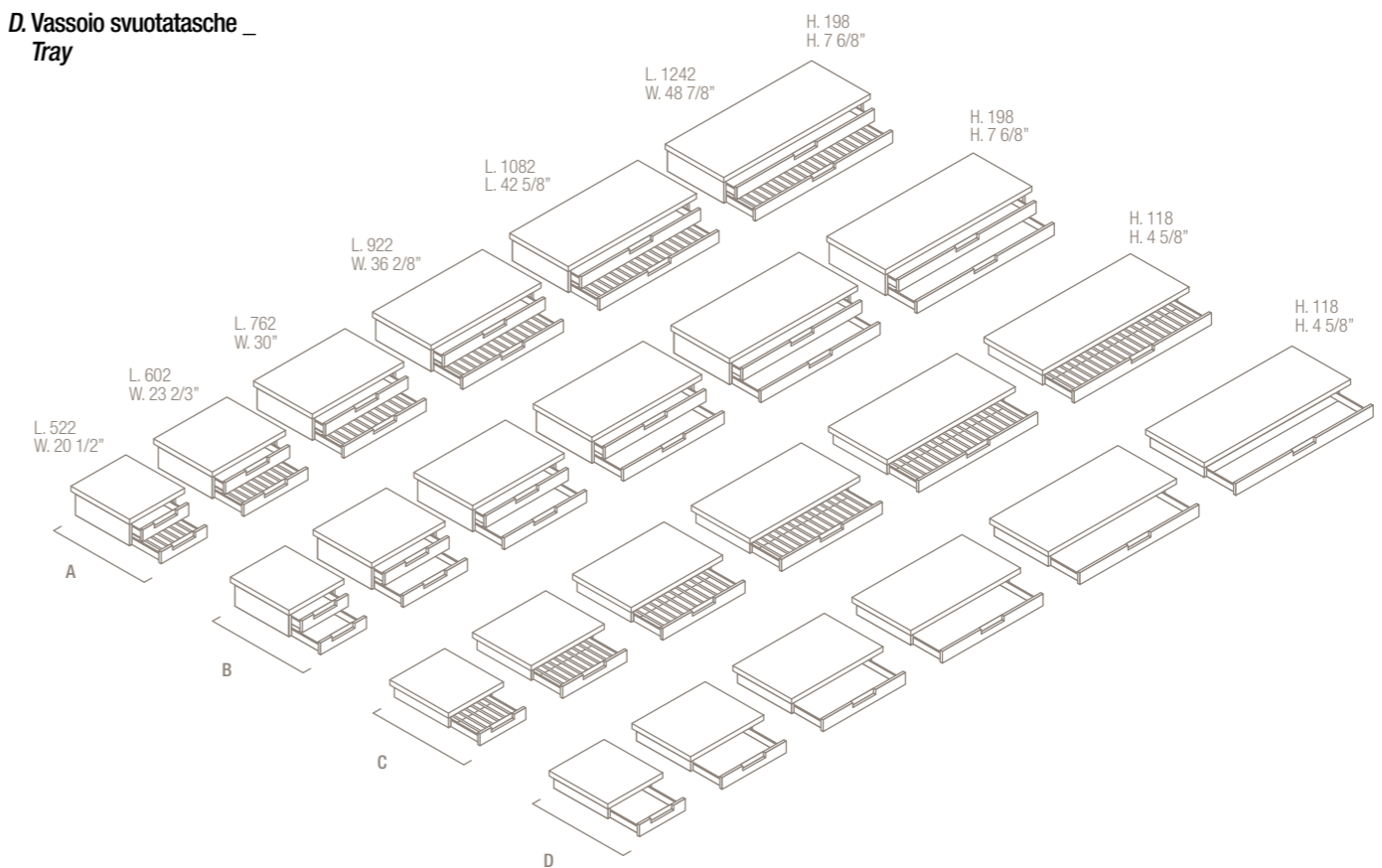

MANIGLIE _ HANDLES

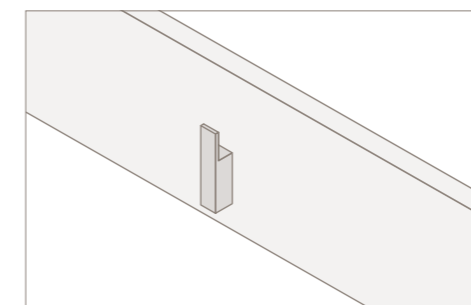

Applique
Disponibile per tutti _ *Available for all*

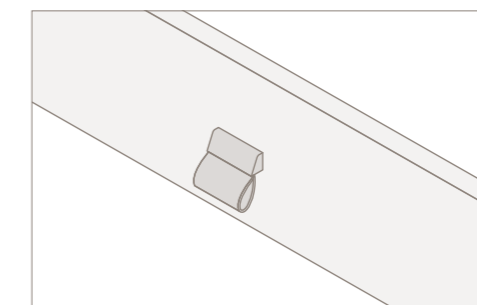

Cardea
Disponibile per tutti _ *Available for all*

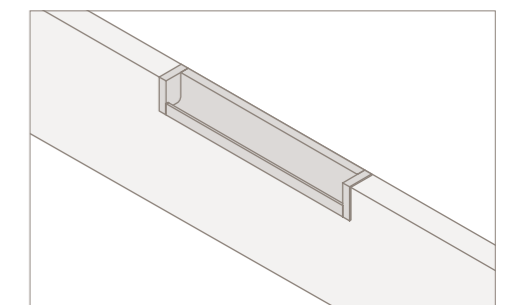

Flush
Disponibile per tutti _ *Available for all*

Elementi sospesi _ *Hanging elements*TIPOLOGIE FRONTALI LEGNO _ *TYPLOGIES FRONTAL WOOD***VASSOIO SVUOTATASCHE**

Vassoio H. 80 mm estraibile con frontale in nobilitato o laccato opaco tutte le finiture, parte estraibile verniciata Canna di Fucile e fondo nobilitato Primo Fiore. Dimensioni: L. 522, L. 602, L. 762, L. 922, L. 1082 e L. 1242 mm. Disponibile con maniglia APPLIQUE, CARDEA e FLUSH.

PULL-OUT TRAY

Pull-out tray height 3 1/8" with melamine or matt lacquered front all finishings, pull-out Gunmetal varnished part and bottom melamine Primo Fiore. Dimensions: W. 20 1/2", W. 23 2/3", W. 30", W. 36 2/8", W. 42 5/8" and W. 48 7/8". Available with handle APPLIQUE, CARDEA and FLUSH.

**PORTAPANTALONI**

Vassoio H. 80 mm estraibile con frontale in nobilitato o laccato opaco tutte le finiture, parte estraibile verniciata Canna di Fucile e fondo nobilitato Primo Fiore, attrezzato con bacchette portapantaloni. Dimensioni: L. 522 (n° 4 bacchette), L. 602 (n° 5 bacchette), L. 762 (n° 6 bacchette), L. 922 (n° 8 bacchette), L. 1082 (n° 10 bacchette) e L. 1242 mm (n° 12 bacchette). Disponibile con maniglia APPLIQUE, CARDEA e FLUSH.

TROUSERS HOLDER

Pull-out tray height 3 1/8" with melamine or matt lacquered front all finishings, pull-out Gunmetal varnished part and bottom melamine Primo Fiore, equipped with trousers holder sticks. Dimensions: W. 20 1/2" (n° 4 sticks), W. 23 2/3" (n° 5 sticks), W. 30" (n° 6 sticks), W. 36 2/8" (n° 8 sticks), W. 42 5/8" (n° 10 sticks) and W. 48 7/8" (n° 12 sticks). Available with handle APPLIQUE, CARDEA and FLUSH.

DOPPIO VASSOIO SVUOTATASCHE

Doppio vassoio H. 80 mm estraibile con frontale in nobilitato o laccato opaco tutte le finiture, parte estraibile verniciata Canna di Fucile e fondo in nobilitato Primo Fiore. L. 522, L. 602, L. 762, L. 922, L. 1082 e L. 1242 mm. Disponibile con maniglia APPLIQUE, CARDEA e FLUSH.

PULL-OUT DRESSER DOUBLE TRAY

Pull-out double tray height 3 1/8" with melamine or matt lacquered front all finishings, pull-out Gunmetal varnished part and bottom melamine Primo Fiore. Dimensions: W. 20 1/2", W. 23 2/3", W. 30", W. 36 2/8", W. 42 5/8" and W. 48 7/8". Available with handle APPLIQUE, CARDEA and FLUSH.

TIPOLOGIE FRONTALI LEGNO _ *TYPLOGIES FRONTAL WOOD***PORTAPANTALONI E VASSOIO SVUOTATASCHE**

Doppio vassoio H. 80 mm estraibile con frontale in nobilitato e laccato opaco tutte le finiture e parte estraibile verniciata Canna di Fucile. Uno attrezzato con vassoio svuotatasche e l'altro con portapantaloni. Fondo in nobilitato Primo Fiore. Dimensioni: L. 522, L. 602, L. 762, L. 922, L. 1082 e L. 1242 mm. Disponibile con maniglia APPLIQUE, CARDEA e FLUSH.

TROUSERS HOLDER AND PULL-OUT TRAY

Pull-out double tray height 3 1/8" with melamine front or matt lacquered all finishings and pull-out Gunmetal varnished part. One equipped with pull-out tray and the other with trousers holder. Bottom melamine Primo Fiore. Dimensions: W. 20 1/2", W. 23 2/3", W. 30", W. 36 2/8", W. 42 5/8" and W. 48 7/8". Available with handle APPLIQUE, CARDEA and FLUSH.

N.B.

La struttura degli elementi sospesi è costituita da un coperchio in nobilitato, laccato opaco o ecopelle tutte le finiture per tutti gli elementi sospesi vale lo stesso schema di utilizzo _ *The hanging element structure is composed by melamine, matt lacquered or eco-leather all finishings top the same use scheme applies to all suspended elements*

	spalle telaio side frame	spalle legno wood side	profondità 340 depth 13 1/3"	profondità 546 depth 21 1/2"
I-Box	•	•		•
Free				•
Wall				•

Elementi sospesi _ *Hanging elements*ATTREZZATURA SVUOTATASCHE _ *PULL-OUT TRAY EQUIPMENT***DIVISORIO INTERNO IN ECOPELLE PER VASSOI SVUOTATASCHE**

Tappetino con cuciture e divisori in ecopelle per fondo vassoio svuotatasche. Disponibile in tutte le finiture.

ECO-LEATHER INNER PARTITION FOR PULL-OUT TRAY

Mat with stitching and eco-leather inner partition for bottom pull-out trays. Available in all finishings.

Elementi dedicati _ *Dedicated elements*





Elementi dedicati _ Dedicated elements

PORTA SCARPE _ SHOESTAND SHELF



RIPIANO PORTASCARPE INCLINATO

Elemento in nobilitato o laccato opaco tutte le finiture, attrezzato con profilo bordo ed elementi battitacco in alluminio verniciati Canna di Fucile.

INCLINED SHOESTAND SHELF

Melamine and matt lacquered element in all finishings, equipment with a Gunmetal varnished edges and shoes dividers.

	spalle telaio side frame	spalle legno wood side	profondità 340 depth 13 1/3"	profondità 546 depth 21 1/2"
I-Box	•	•	•	•
Free				•
Wall			•	•

ORGANIZZAZIONE RIPIANI PORTASCARPE P. 586 MM _ SHOES RACK SHELVES ORGANIZATION D. 23 1/8"

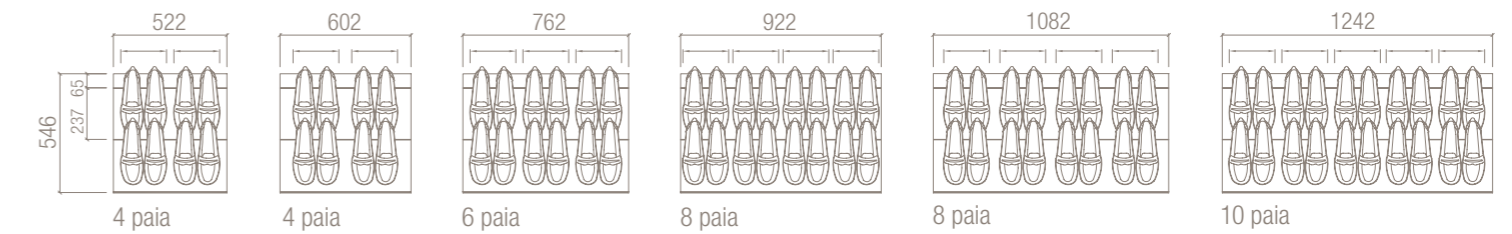

ORGANIZZAZIONE RIPIANI PORTASCARPE P. 380 MM _ SHOES RACK SHELVES ORGANIZATION D. 15"

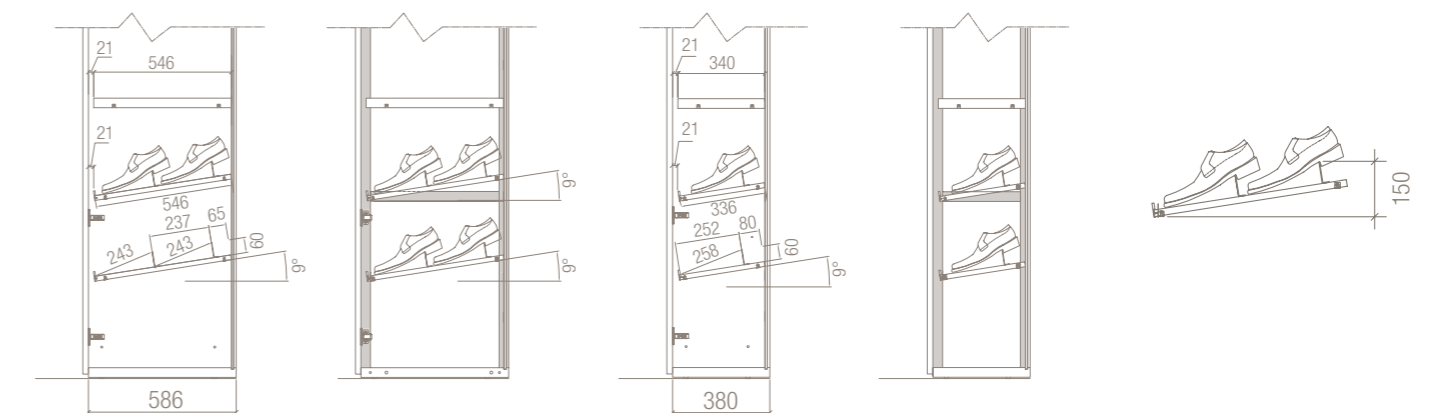
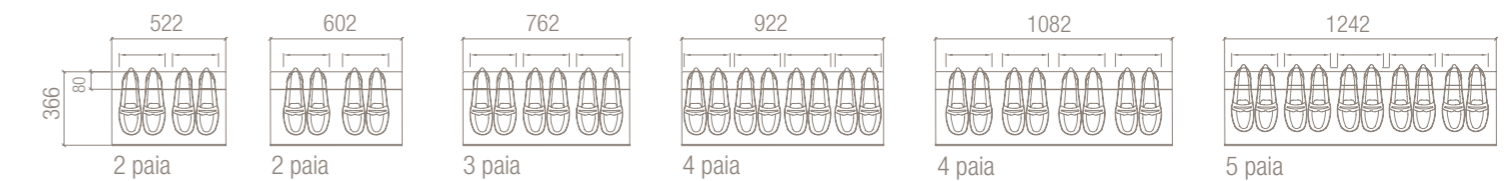



Elementi dedicati _ *Dedicated elements*

PORTA BORSE / PORTACAMICIE _ *BAG HOLDER / SHIRTS HOLDER*

A. Soluzioni dedicate per I-Box _ *I-Box dedicated solutions*

B. Soluzioni dedicate per Free e Wall _ *"Free" and "Wall" dedicated solutions*

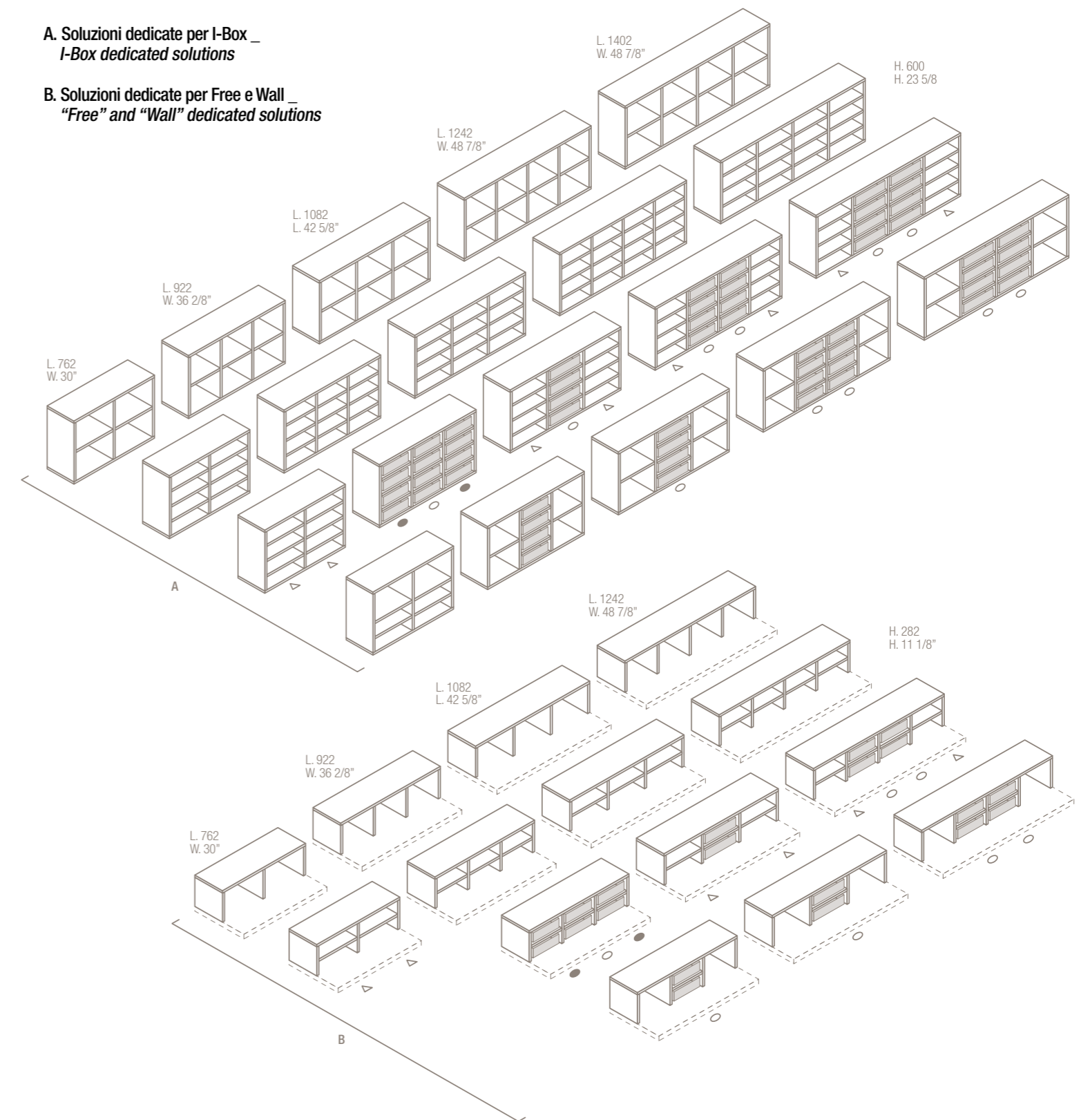

○ Possibile inserire scatola

△ Non è possibile inserire scatola

● È possibile inserire scatola solo con ante Rex, Narcisse o Zeus

Elementi dedicati _ *Dedicated elements***PORTACAMICIE _ *SHIRTS HOLDER*****PORTACAMICIE**

Elemento H. 602 mm P. 380 mm per I-Box, H. 282 mm P. 380 mm Free e Wall. Struttura Sp. 19 mm in nobilitato e laccato opaco tutte le finiture con ripiani interni in nobilitato Primofiore Sp. 14 mm o vetro Sp. 12 mm nelle finiture fumé o trasparente. Da utilizzare in appoggio su ripiani o cassettiere, o tra ripiani. Dimensione vano interno H. 130mm.

SHIRTS SYSTEM

Element H. 23 6/8" D. 15" for I-Box, H.11 1/8" D. 15" for Free & Wall, with melamine structure and matt lacquered in all finishings (Th. 6/8") with inner shelves in Primofiore melamine (Th. 1/2") or fumé glass or transparent glass (Th. 1/2"). To be used on top of shelves or chest of drawers, or between shelves. Internal compartments dimension H. 5 1/8".

	spalle telaio side frame	spalle legno wood side	profondità 380 depth 13 1/3"	profondità 546 depth 21 1/2"
I-Box	•	•	•	•
Free				•
Wall			•	•

CASSETTI OPZIONALI PER PORTACAMICIE

Cassetti rivestiti in tutte le ecopelli a catalogo utilizzabili con unica dimensione.

OPTIONAL DRAWERS FOR SHIRTS

Drawers covered in all listed eco-leather that can be used with a single dimension.

**N.B.**

Non è possibile l'utilizzo del contenitore Portacamicie e Portaborse, nella profondità P. 380 mm in presenza di ante battenti
It is not possible to use the container shirts storage and handbags storage, in the depth. of 380 mm with hinged doors

PORTA BORSE _ *BAG HOLDER***PORTABORSE**

Elemento H. 602 mm P. 380 mm per I-Box, H. 282 mm P. 380 mm Free e Wall. Struttura Sp. 19 mm in nobilitato o laccato opaco tutte le finiture con ripiani interni in nobilitato Primofiore Sp. 14 mm o vetro Sp. 12 mm nelle finiture fumé o trasparente. Da utilizzare in appoggio su ripiani o cassettiere, o tra ripiani. Dimensione vano interno H. 274 mm.

HANDBAGS

Element H. 23 6/8" D. 15" for I-Box, H.11 1/8" D. 15" for Free & Wall, with melamine structure all finishings (Th. 6/8") with inner shelves in Primofiore melamine (Th. 1/2") or fumé glass or transparent glass (Th. 1/2"). To be used on top of shelves or chest of drawers, or between shelves. Internal compartments dimension H. 10 6/8".

	spalle telaio side frame	spalle legno wood side	profondità 380 depth 13 1/3"	profondità 546 depth 21 1/2"
I-Box	•	•	•	•
Free				•
Wall			•	•

CASSETTI OPZIONALI PER PORTABORSE

Cassetti rivestiti in tutte le ecopelli a catalogo utilizzabili con unica dimensione.

OPTIONAL DRAWERS FOR HANDBAGS

Drawers covered in all listed eco-leather that can be used with a single dimension.

**N.B.**

Non è possibile l'utilizzo del contenitore Portacamicie e Portaborse, nella profondità P. 380 mm in presenza di ante battenti
It is not possible to use the container shirts storage and handbags storage, in the depth. of 380 mm with hinged doors

Elementi dedicati _ *Dedicated elements*PORTABIANCHERIA _ *LAUNDRY HOLDER***PORTABIANCHERIA**

Elemento H. 640 mm e P. 546 mm costituito da un top in legno o ecopelle e un unico cassetto in nobilitato o laccato opaco tutte le finiture, dotato di una sacca portabiancheria. Disponibile con maniglia APPLIQUE, CARDEA e FLUSH.

LAUNDRY HOLDER

Element H. 25 2/8" and D. 21 1/2" consisting of a wooden or eco-leather top and one melamine or matt lacquered drawer all finishings, equipped with a laundry bag. Available with handle APPLIQUE, CARDEA and FLUSH.

Dimensioni:

L. 522 mm (1 cesto),
L. 762 mm (1 cesto + vani),
L. 922 mm (1 cesto + vani),
L. 1082 mm (1 cesto + vani o 2 cesti),
L. 1242 mm (1 cesto + vani)

Dimensions:

W. 20 1/2" (1 holder),
W. 30" (1 holder + compartments),
W. 36 2/8" (1 holder + compartments),
W. 42 5/8" (1 holder + compartments or 2 holders),
W. 48 7/8" (1 holder + compartments)

spalle telaio	spalle legno	profondità	340	profondità	546
side frame	wood side	depth	13 1/3"	depth	21 1/2"

I-Box
Free
Wall

• • •



Elementi Hi-tech _ *Hi-tech elements*



Elementi Hi-tech _ *Hi-tech elements*

TIPOLOGIE ELEMENTI HI-TECH_ *HI-TECH ELEMENTS TYPOLOGIES*

A. Vassoio estraibile _
Pull-out tray

B. Cassetto estraibile _
Pull-out drawer

C. Portapantaloni estraibile _
Pull-out trouser holder

D. Portascarpe estraibile _
Pull-out shoes rack

E. Portabiancheria estraibile con sacca _
Pull-out laundry holder with bag

F. Vassoio estraibile con fondo vetro Fumè o legno _
Pull-out tray with Fumè glass or wooden bottom

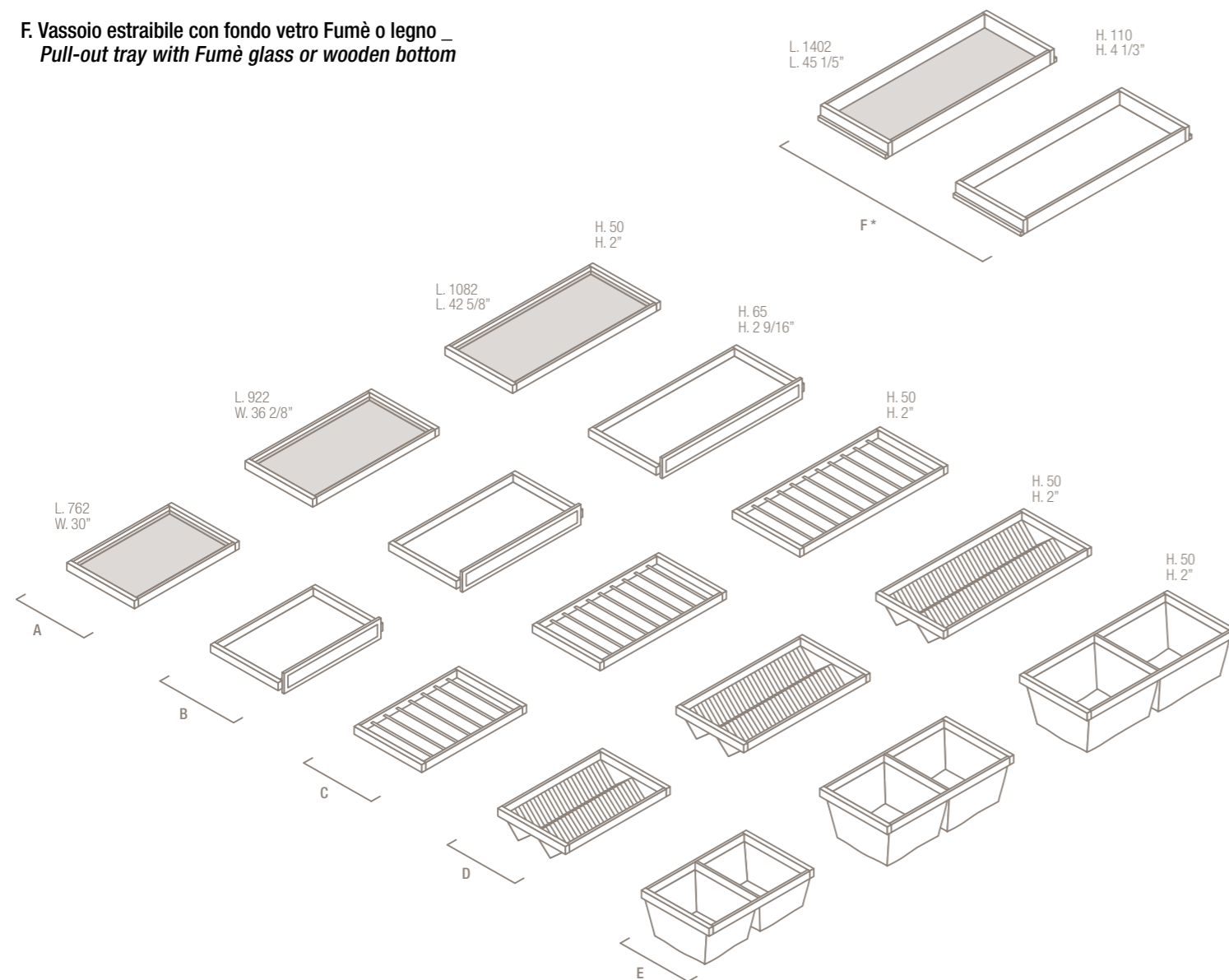

* Solo per Palo Alto I-Box
Only available for Palo Alto I-Box



Elementi Hi-tech _ *Hi-tech elements*

TIPOLOGIE _ *TYPLOGIES*



VASSOIO ESTRAIBILE

Vassoio estraibile H. 50 mm P. 500 mm con fondo in vetro fumé. Telaio in alluminio 4 lati verniciato Canna di Fucile. Dimensioni: L. 762 mm, L. 922 mm, L. 1082 mm.

PULL-OUT TRAY

Pull-out tray H. 2" D. 19 5/8" with fumé glass bottom. 4 side aluminum frame Gunmetal varnished. Dimensions: W. 30", W. 36 2/8", W. 42 5/8".

	spalle telaio side frame	spalle legno wood side	profondità depth	340 13 1/3"	profondità depth	586 23"
I-Box	•	•				•
Free						•
Wall						•



CASSETTO ESTRAIBILE CON FONDO IN VETRO FUMÉ

Cassetto estraibile H. 65 mm P. 500 mm con fondo in vetro fumé. Telaio in alluminio 3 lati verniciato Canna di Fucile con frontale in vetro fumé. Dimensioni: L. 762 mm, L. 922 mm, L. 1082 mm.

PULL-OUT DRAWER WITH FUMÉ GLASS BOTTOM

Pull-out drawer H. 2 1/2" D. 19 5/8" with fumé glass bottom. 3 side aluminum frame Gunmetal varnished with fumé glass front. Dimensions: W. 30", W. 36 2/8", W. 42 5/8".

	spalle telaio side frame	spalle legno wood side	profondità depth	340 13 1/3"	profondità depth	586 23"
I-Box	•	•				•
Free						•
Wall						•



CASSETTO ESTRAIBILE CON FONDO IN LEGNO

Cassetto estraibile H. 65 mm P. 500 mm con fondo in nobilitato Primo Fiore. Telaio in alluminio 3 lati verniciato Canna di Fucile con frontale in vetro fumé. Dimensioni: L. 762 mm, L. 922 mm, L. 1082 mm.

PULL-OUT DRAWER WITH WOODEN BOTTOM

Pull-out drawer H. 2 1/2" D. 19 5/8" with melamine Antracite Primofiore bottom. 3 side aluminum frame Gunmetal varnished with fumé glass front. Dimensions: W. 30", W. 36 2/8", W. 42 5/8".

	spalle telaio side frame	spalle legno wood side	profondità depth	340 13 1/3"	profondità depth	586 23"
I-Box	•	•				•
Free						•
Wall						•

TIPOLOGIE _ *TYPLOGIES*



PORTAPANTALONI ESTRAIBILE

Portapantaloni estraibile H. 50 mm P. 500 mm. Telaio in alluminio 4 lati verniciato Canna di Fucile, attrezzato con bacchette portapantaloni. Dimensioni: L. 762 mm (n° 7 bacchette), L. 922 mm (n° 9 bacchette), L. 1082 mm (n° 10 bacchette).

PULL-OUT TROUSERS HOLDER

Pull-out trousers holder H. 2" D. 19 5/8" . 4 side aluminum frame Gunmetal varnished, equipped with trousers holder sticks. Dimensions: W. 30" (n° 7 sticks), W. 36 2/8" (n° 9 sticks), W. 42 5/8" (n° 10 sticks).

	spalle telaio side frame	spalle legno wood side	profondità depth	340 13 1/3"	profondità depth	586 23"
I-Box	•	•				•
Free						•
Wall						•



PORTASCARPE ESTRAIBILE

Portascarpe estraibile H. 50 mm P. 500 mm con 2 scomparti. Telaio in alluminio 4 lati verniciato Canna di Fucile. Dimensioni: L. 762 mm, L. 922 mm, L. 1082 mm.

PULL-OUT SHOES RACK

Pull-out shoes rack H. 2" D. 19 5/8" with two compartments. 4 side aluminum frame Gunmetal varnished. Dimensions: W. 30", W. 36 2/8", W. 42 5/8".

	spalle telaio side frame	spalle legno wood side	profondità depth	340 13 1/3"	profondità depth	586 23"
I-Box	•	•				•
Free						•
Wall						•



PORTABIANCHERIA ESTRAIBILE CON SACCA

Portabiancheria estraibile H. 50 mm P. 500 mm con sacca in ecopelle in tutte le finiture. Telaio in alluminio 4 lati verniciato Canna di Fucile. Dimensioni: L. 762 mm, L. 922 mm, L. 1082 mm.

PULL-OUT LAUNDRY HOLDER WITH BAG

Pull-out laundry holder H. 2" D. 19 5/8" with eco-leather bag all finishing. 4 side aluminum frame Gunmetal varnished. Dimensions: W. 30", W. 36 2/8", W. 42 5/8".

	spalle telaio side frame	spalle legno wood side	profondità depth	340 13 1/3"	profondità depth	586 23"
I-Box	•	•				•
Free						•
Wall						•



Elementi Hi-tech _ *Hi-tech elements*

ACCESSORI PER ELEMENTI HI-TECH _ *EQUIPMENT FOR HI-TECH ELEMENTS*



TAPPETINO OPZIONALE IN ECOPELLE PER CASS. ESTRAIBILE
Tappetino senza cuciture per fondo cassetti e vassoi estraibili. Disponibile in tutte le finiture.

ECO-LEATHER OPTIONAL MAT FOR DRAWERS AND TRAYS
Mat without stitching for bottom pull-out drawers and trays. Available in all finishings.



DIVISORIO INTERNO IN ECOPELLE
Tappetino con cuciture e divisori in ecopelle per fondo cassetti e vassoi estraibili. Disponibile in tutte le finiture.

ECO-LEATHER INNER PARTITION FOR DRAWERS AND TRAYS
Mat with stitching and ecoleather inner partition for bottom pull-out drawers and trays. Available in all finishings.



PORTA OROLOGI/ORECCHINI/ANELLI
Gli accessori porta orologi/orecchini/anelli possono essere inseriti nei cassetti e nei vassoi estraibili, anche in presenza del divisorio interno in ecopelle.

Per proposta accessori pag. 382-383

WATCHES/EARRINGS/RINGS HANGER
Watches/earrings/rings hangers can be inserted in the pull-out drawers and trays, even in the presence of eco-leather inner partition.

For equipment options pages 382-383

Elemento ad Isola _ *Island element*



Elemento ad isola _ *Island element*

TIPOLOGIE ISOLA _ ISLAND TYPOLOGIES

A. Cassettiere free-standing monofacciali.

Con vano a giorno e cassetti.

Piano disponibile in vetro, legno, ecopelle o pelle.

Single-sided free-standing chest of drawers.

With open compartment and drawers.

Top available in glass, wood, eco-leather or leather.

B. Cassettiere free-standing bifacciali.

Con vano a giorno e cassetti.

Piano disponibile in vetro, legno, ecopelle o pelle.

Double-sided free-standing chest of drawers.

With open compartment and drawers.

Top available in glass, wood, eco-leather or leather.

C. Cassettiere free-standing monofacciali con cassetti.

Piano disponibile in legno, ecopelle o pelle.

Single-sided free-standing chest of drawers with drawers.

Top available in wood, eco-leather or leather.

D. Cassettiere free-standing bifacciali con cassetti.

Piano disponibile in legno, ecopelle o pelle.

Double-sided free-standing chest of drawers with drawers.

Top available in wood, eco-leather or leather.

E. Cassettiere free-standing bifacciali asimmetriche.

Fronte con cassetti, retro con vani a giorno.

Piano in vetro.

Double-sided free-standing asymmetric chest of drawers.

Front with drawers, back with open compartments.

Top in glass.

F. Cassettiere free-standing bifacciali in vetro.

Fronte con cassetti e vani a giorno, retro con vani a giorno.

Piano disponibile in legno, ecopelle o pelle.

Free-standing double-sided glass chest of drawers.

Front with drawers and open compartments, back with open compartments. Top available in wood, eco-leather or leather.

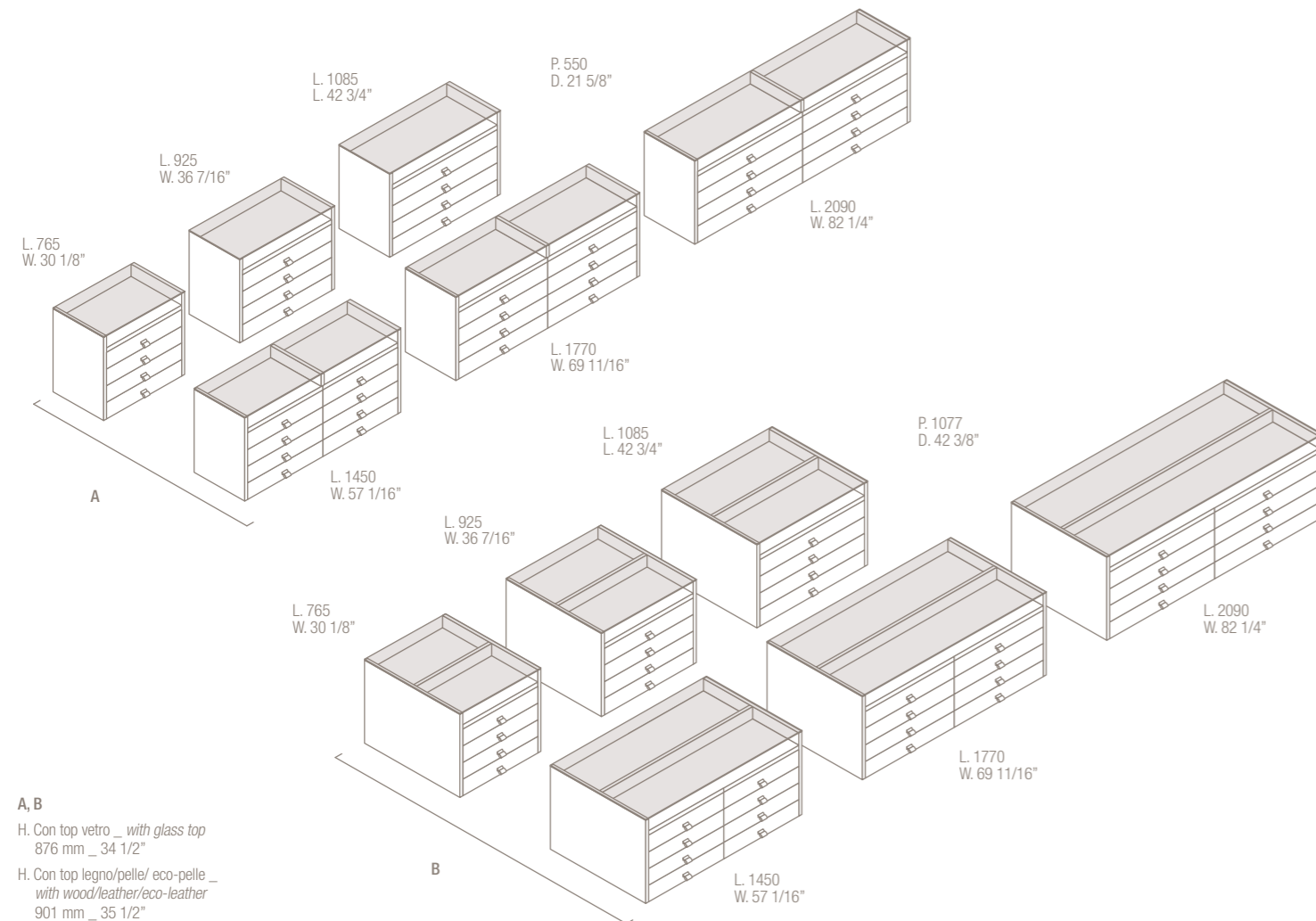

A, B

H. Con top vetro _ with glass top
876 mm _ 34 1/2"

H. Con top legno/pelle/ eco-pelle _
with wood/leather/eco-leather
901 mm _ 35 1/2"

TIPOLOGIE ISOLA _ ISLAND TYPOLOGIES

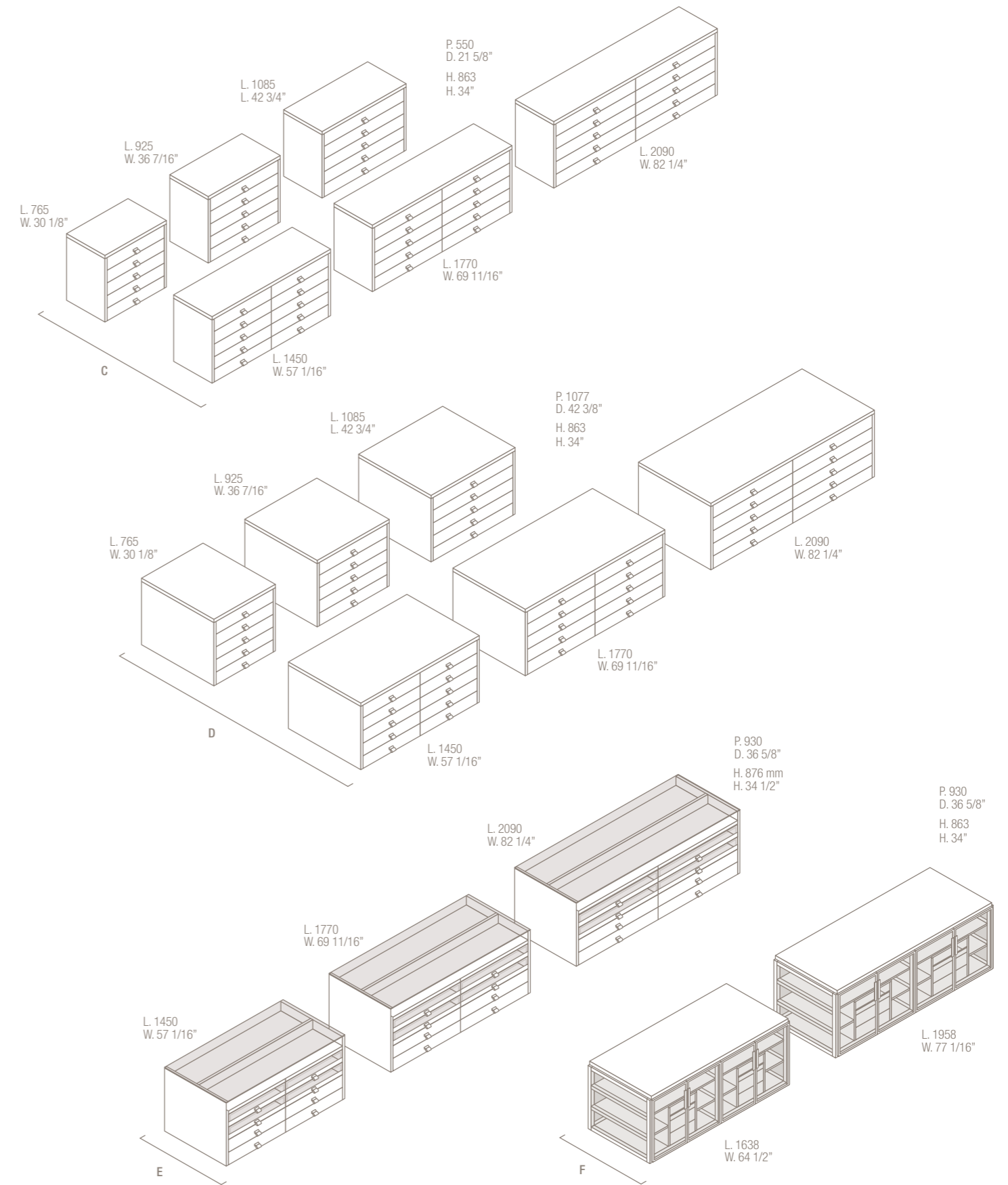

Elemento ad Isola _ *Island element*TIPOLOGIE ISOLA _ *ISLAND TYPOLOGIES***CASSETTIERA FREE-STANDING VANO A GIORNO**

Disponibile in due profondità, P. 550 mm e P. 1077 mm.
Possibilità top in legno, pelle o ecopelle Sp. 38 mm (cassettiera H. 901 mm) o top in vetro Sp. 12 mm (cassettiera H. 875 mm).
Struttura in nobilitato o laccato opaco tutti colori.
Disponibile in 6 larghezze: L. 765 mm, L. 925 mm, L. 1085 mm, L. 1450 mm, L. 1770 mm, L. 2090 mm.

FREE-STANDING CHEST OF DRAWERS WITH OPEN COMPARTMENT

Available in two depths: D. 21 5/8" and D. 42 3/8".
Wood, leather or ecol-eather top Thickness 1 1/2" (chest of drawers H. 35 1/2") or glass top Thickness 1/2" (chest of drawers 34 1/2"). Structures in melamine finishings or all matt lacquered colours. Available in 6 width; W. 30 1/8", W. 36 3/8", W. 42 6/8", 57 1/8", 69 5/8", W. 82 2/8".

**CASSETTIERA FREE-STANDING LEGNO**

Disponibile in due profondità, P. 550 mm e P. 1077 mm, e H. 863 mm. Possibilità top in legno, pelle o ecopelle Sp. 38 mm. Struttura in nobilitato o laccato opaco tutti colori.
Disponibile in 6 larghezze: L. 765 mm, L. 925 mm, L. 1085 mm, L. 1450 mm, L. 1770 mm, L. 2090 mm.

FREE-STANDING WOODEN CHEST OF DRAWERS

Available in two depths, D. 21 5/8" and D. 42 3/8", and H. 34". Wooden, leather or eco-leather top Thickness 1 1/2". Structures in melamine finishings or all matt lacquered colours. Available in 6 width; W. 30 1/8", W. 36 3/8", W. 42 6/8", 57 1/8", 69 5/8", W. 82 2/8".

**CASSETTIERA FREE-STANDING VETRO**

Disponibile in un'unica dimensione P. 1077 mm, H. 863 mm L. Top in pelle o ecopelle Sp. 38 mm.

FREE-STANDING GLASS CHEST OF DRAWERS

Available in one depth D. 42 3/8" and H. 34".
Leather or eco-leather top Thickness 1 1/2".



Accessori _ *Accessories*



Accessori _ Accessories

ATTREZZATURA _ EQUIPMENT



SERVETTO

Predisposto per aggancio ai fianchi legno.
Per vano L. 762 mm, 922 mm, 1082 mm, 1242 mm, 1402 mm. Finitura verniciato Canna di Fucile.

PULL DOWN HANGING BAR

Foreseen to be fixed on the wooden sides. For units W. 30", 36 2/8", 42 5/8", 48 7/8", 55 2/8".
Varnished Gunmetal finishing.

spalle telaio _ side frame spalle legno _ wood side

I-Box
Free
Wall



APPENDIABITI

Predisposti per aggancio al coperchio o ripiano interno.
Disponibili in tutte le larghezze previste dal sistema Palo Alto, per colonne terminali che angolari. Finitura verniciata in tutte le finiture metallizzate (1), oppure rivestito in ecopelle nel colore a scelta (2).

HANGING RAIL

Foreseen to be fixed on the top or inner shelf. Available in all widths of Palo Alto system, also for ending and corner columns.
Varnished in all metallic finishing (1), alternatively covered in eco-leather in the color of your choice (2).

spalle telaio _ side frame spalle legno _ wood side

I-Box
Free
Wall

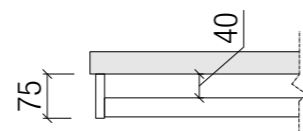

ATTREZZATURA _ EQUIPMENT



PERNO ESTRAIBILE APPENDIABITI RIPIANI LEGNO

Da posizionare al centro dello spessore dei ripiani.
Finitura verniciato Canna di Fucile.

PULL-OUT HOOK WOOD SHELVES

To be fixed in the middle of the shelves thickness.
Varnished Gunmetal finishing.

spalle telaio _ side frame spalle legno _ wood side

I-Box
Free
Wall



PERNO ESTRAIBILE APPENDIABITI RIPIANI ECOPELLE

Da posizionare sotto i ripiani in ecopelle.
Finitura verniciato Canna di Fucile.

PULL-OUT HOOK ECO-LEATHER SHELVES

To be fixed under eco-leather shelves.
Varnished Gunmetal finishing.

spalle telaio _ side frame spalle legno _ wood side

I-Box
Free
Wall

Accessori _ Accessories

ATTREZZATURA _ EQUIPMENT

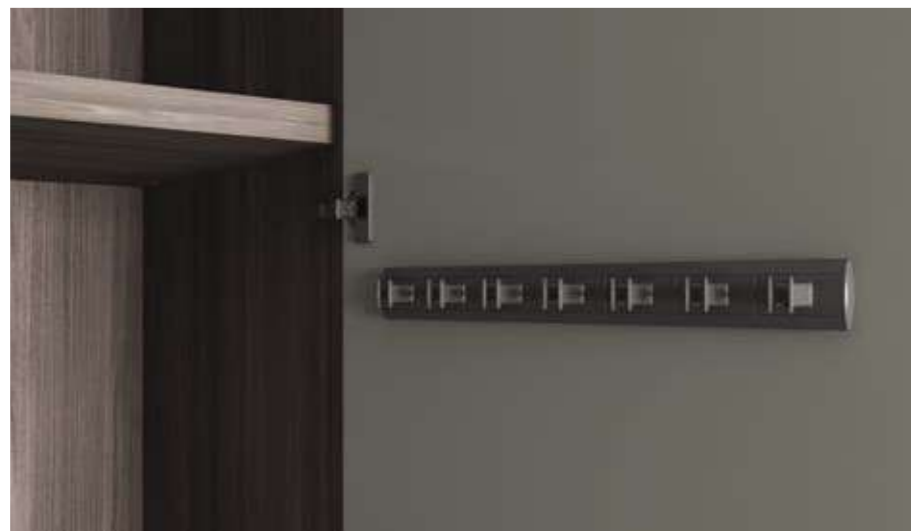

PORTACINTURE

Predisposto per fissaggio su retro anta battente.
L. 440 mm, dotato di N. 7 ganci, in finitura verniciato Canna di fucile con particolari finitura opalino.

BELT HANGER BAR

To be fixed behind hinged door.
W. 17 3/8", equipped with N. 7 hooks, Gunmetal varnished, with details in opal finishing.

	spalle telaio side frame	spalle legno wood side	profondità depth	340 13 1/3"	profondità depth	546 21 1/2"
I-Box	•	•	•			•
Free						•
Wall						



PORTACRAVATTE

Predisposto per fissaggio su retro anta battente.
L. 440 mm, dotato di N. 28 ganci, in finitura verniciato Canna di Fucile con particolari finitura opalino.

TIES HANGER

To be fixed behind hinged door.
W. 17 3/8", equipped with N. 28 hooks, Gunmetal varnished, with details in opal finishing.

	spalle telaio side frame	spalle legno wood side	profondità depth	340 13 1/3"	profondità depth	546 21 1/2"
I-Box	•	•	•			•
Free						•
Wall						



PORTA FOULARDS

Predisposto per fissaggio su retro anta battente.
L. 440 mm, dotato di N. 8 mollette, in finitura verniciato Canna di Fucile con particolari finitura opalino.

FOULARDS HANGER

To be fixed behind hinged door.
W. 17 3/8", equipped with N. 8 clips, Gunmetal varnished, with details in opal finishing.

	spalle telaio side frame	spalle legno wood side	profondità depth	340 13 1/3"	profondità depth	546 21 1/2"
I-Box	•	•	•			•
Free						•
Wall						

ATTREZZATURA _ EQUIPMENT



PORTACINTURE ESTRAIBILE

Predisposto per fissaggio su spalla interna del modulo (per spalla legno) o sotto ripiano (per spalla telaio).
L. 510 mm, dotato di N. 8 ganci, in finitura verniciato metallizzato Grafite con particolari finitura opalino.

PULL-OUT BELTS HANGER

Prepared for mounting on the inner side panel of the module (for wooden side panel) or under the shelf (for side frame).
W. 20 1/8", equipped with N. 8 hooks, varnished metallic Graphite with details in opal finishing.

	spalle telaio side frame	spalle legno wood side	profondità depth	340 13 1/3"	profondità depth	546 21 1/2"
I-Box		•				•
Free						
Wall						



PORTACRAVATTE ESTRAIBILE

Predisposto per fissaggio su spalla interna del modulo (per spalla legno) o sotto ripiano (per spalla telaio).
L. 510 mm, dotato di N. 32 ganci, in finitura verniciato metallizzato Grafite con particolari finitura opalino.

PULL-OUT TIES HANGER

Prepared for mounting on the inner side panel of the module (for wooden side panel) or under the shelf (for side frame).
W. 20 1/8", equipped with N. 32 hooks, varnished metallic Graphite with details in opal finishing.

	spalle telaio side frame	spalle legno wood side	profondità depth	340 13 1/3"	profondità depth	546 21 1/2"
I-Box		•				•
Free						
Wall						



PORTA FOULARD ESTRAIBILE

Predisposto per fissaggio su spalla interna del modulo (per spalla legno) o sotto ripiano (per spalla telaio).
L. 510 mm, dotato di N. 8 mollette, in finitura verniciato metallizzato Grafite con particolari finitura opalino.

PULL-OUT FOULARD HANGER

Prepared for mounting on the inner side panel of the module (for wooden side panel) or under the shelf (for side frame).
W. 20 1/8", equipped with N. 8 clips, varnished metallic Graphite with details in opal finishing.

	spalle telaio side frame	spalle legno wood side	profondità depth	340 13 1/3"	profondità depth	546 21 1/2"
I-Box		•				•
Free						
Wall						



Accessori _ Accessories

ATTREZZATURA _ EQUIPMENT



SACCHE

In confezione da due pezzi con sacche in tessuto, dotata di bottoni per adattare l'altezza della sacca in due posizioni.
Dimensioni: L. 58 mm, H. 950/1150 mm.

BAGS

2 pieces package with anthracite fabric bags, equipped with buttons to adapt the height of the bag in two positions.
Dimensions: W. 2 2/8", H. 3 6/8" or 4 1/2".



GRUCCIA CON E SENZA ASTA

In confezione da due pezzi.
Finitura Olmo grey e serigrafia marchio.
Dimensioni: L. 465 mm, H. 215 mm, P. 65 mm.
Per il calcolo dimensionale del proprio vestito in un vano, sommare all'altezza del vestito circa 100 mm di ingombro per la gruccia.

COAT HANGER WITH AND WITHOUT BAR

2 pieces package.
Elm grey finishing and logo silkscreen.
Dimensions: W. 18 2/8", H. 8 1/2", D. 2 1/2".
To calculate the size of your clothes in a compartment, add about 3 7/8 of space for the hanger to the height of the dress.



SCATOLE CON COPERCHIO

In confezione da due pezzi rivestite in tessuto e particolare in cuoio Testa di Moro con incisione del marchio.
Disponibili in due altezze: H. 130 mm, H. 260 mm.
Dimensioni: L. 400 mm, P. 480 mm.

BOX WITH COVER

2 pieces package fabric cover. Detail in Testa di Moro thick leather with the brand engraved.
Available in 2 heights: H. 5 1/8", H. 10 2/8".
Dimensions: W. 15 6/8", D. 18 7/8".

Accessori _ Accessories

ATTREZZATURA _ EQUIPMENT

**SPECCHIO RETRO ANTA**

Da applicare all'interno di un'anta battente dx o sx di larghezza L. 476/556 mm.

Disponibile con specchio naturale.

Dimensioni specchio: L. 350 mm e H. 1500 mm o 1800 mm.

BEHIND-DOOR MIRROR

To be applied inside a hinged door, right or left, of width W. 18 6/8" / 21 7/8".

Available with natural mirror.

Mirror dimensions: W. 13 6/8" and H. 59" or 70 7/8".

ATTREZZATURA _ EQUIPMENT

**SPECCHIO RETRO ANTA ORIENTABILE**

Da applicare all'interno di un'anta battente dx o sx di larghezza L. 476/556 mm.

Disponibile con specchio naturale.

Dimensioni specchio: L. 385 mm e H. 1400 mm.

SWIVELING BEHIND-DOOR MIRROR

To be applied inside a hinged door, right or left, of width W. 18 6/8" / 21 7/8".

Available with natural mirror.

Mirror dimensions: W. 15 1/8" and H. 55 1/8".

Accessori _ Accessories

ATTREZZATURA _ EQUIPMENT

**SPECCHIO ESTRAIBILE E ORIENTABILE**

Da posizionare sulla spalla centrale o terminale in legno.
Disponibile per armadi battenti, scorrevoli e coplanari.
Disponibile con specchio naturale.
Dimensioni specchio: L. 440 mm e H. 1400 mm.

EXTRACTABLE AND SWIVELING MIRROR

To be fixed on central/terminal wooden side panel.
Available for hinged, sliding and coplanar wardrobe.
Available with natural mirror.
Mirror dimensions: W. 17 3/8" and H. 55 1/8".

ATTREZZATURA _ EQUIPMENT

**VASCETTA SVUOTA TASCHE**

Da posizionare sui top delle cassettiere o ripiani legno.
Non è possibile applicarlo su ripiani e top in ecopelle.
Disponibile per le larghezze dei ripiani: L. 762 mm, 922 mm, 1082 mm, 1242 mm, 1402 mm.

POCKET EMPTY POCKETS

To be fixed on tops of chest of drawers or wooden shelves.
It is not possible to apply it on eco-leather shelves and tops. Available for shelves widths: W. 30", 36 2/8", 42 5/8", 48 7/8", 55 2/8".

**AIR CUB**

Purificatore d'aria mediante un processo di ionizzazione e ozonizzazione, che elimina fino al 99% degli agenti nocivi per la nostra salute (VOC, batteri, virus, muffe e sostanze allergeniche). Abbinato allo ionizzatore, il profumatore d'ambiente, per ottenere un ulteriore vantaggio: aria delicatamente profumata per un benessere assoluto. Da applicare solo su schienale.
Dimensioni: L. 270 mm, H. 120 mm, P. 30 mm.

AIR CUB

Air purifier through a process of ionization and ozonation, which eliminates up to 99% of agents harmful to our health (VOC, bacteria, viruses, molds and allergenic substances). Combined with the ioniser, the room perfumer, to obtain an additional advantage: delicately perfumed air for absolute well-being. To apply only on the back panel.
Dimensions: W. 10 5/8", H. 4 6/8", D. 1 1/8".

Accessori _ Accessories

SICUREZZA _ SECURITY

**PANNELLO ISPEZIONABILE ASPORTABILE**

Da posizionare su coperchio, spalla laterale, base.

REMOVABLE INSPECTABLE PANEL

To be fixed on top, lateral side panel, base.

spalle telaio	spalle legno	profondità	340	profondità	546
side frame	wood side	depth	13 1/3"	depth	21 1/2"

I-Box
Free
Wall

VANO CASSAFORTE

Vano costituito da due ripiani legno con anta apribile in tutte le finiture legno della struttura. Dimensioni: L. 522 mm, 602 mm, 762 mm, 922 mm, 1082 mm; P. 380 mm; H. 282 mm. Pannello di apertura attrezzabile con serratura.

SAFE COMPARTMENT

Compartment consisting of two wooden shelves with an opening door in all the wood finishes of the structure. Dimensions: W. 20 1/2", 23 6/8", 30", 36 2/8", 42 5/8"; P. 15"; H. 11 1/8". Opening panel that can be equipped with a lock.

spalle telaio	spalle legno	profondità	340	profondità	546
side frame	wood side	depth	13 1/3"	depth	21 1/2"

I-Box
Free
Wall

CASSETTO CASSAFORTE

Cassetto H. 320 mm e L. 522 mm, 762 mm, 922 mm, 1082 mm. Dotato di pannellino ispezionabile, attrezzabile con serratura. Finitura interna nobilitato Primo Fiore.

SAFE DRAWER

Drawer H. 12 5/8" and W. 20 1/2", 30", 36 2/8", 42 5/8". Equipped with inspectable panel that can be equipped with a lock. Melamine Primo Fiore inner finishing.



SICUREZZA _ SECURITY

**SERRATURA/CHIAVE MAGNETICA PER ANTE**

Possibilità di attrezzare tutte le ante con apertura battente (esclusa Anta Rex) con una serratura a chiave o chiave magnetica.

LOCK/MAGNETIC KEY FOR DOORS

It is possible to equip all the doors with hinged opening (excluding Rex Door) with a key lock or magnetic key.

SERRATURA CASSETTIERE

Possibilità di attrezzare tutte le cassettiere sospese e a terra con serratura posizionabile sul primo cassetto. È possibile chiudere il primo cassetto in alto oppure tutti i cassetti. Applicabile solo su frontali legno.

CHEST OF DRAWERS LOCK

It is possible to equip all the chest of drawers with a lock that can be positioned on the first drawer. It is possible to close the first drawer at the top or all the drawers. Applicable only on wooden fronts.



Concept, art direction
MisuraEmme® studio

Styling
Studio Rossella Battaglia
MisuraEmme® studio

Printing
Grafiche Antiga S.p.A.

Copyright
MisuraEmme®

Thanks to
ILLULIAN
ARTEMIDE
OLUCE
PENTA
NAHOOR
VENICEM
TERZANI
NEMO
DE VECCHI
GREGGIO
MEDLARS
MOTTADELLI
MAISON FIRE
IVV

Made in Italy - ODBOBD

MisuraEmme® S.p.A.
Via IV Novembre, 72
22066 Mariano Comense (CO)
Tel. +39 031.754111
Fax. +39 031.744437
info@misuraemme.it
www.misuraemme.it



The mark of
responsible forestry

Cerca prodotti certificati
FSC®



MisuraEmme® si riserva il diritto di apportare ogni modifica mirata al miglioramento funzionale e qualitativo dei propri prodotti.

Testi e disegni presenti in questo stampato hanno scopo divulgativo, per ogni aspetto tecnico e dimensionale fare riferimento ai listini aziendali e relativi aggiornamenti.

MisuraEmme® reserves the right at all time to apply modifications for the functional or qualitative improvement of its products. Text and drawings present in this brochure have a divulgative purpose, for every technical and dimensional aspect please refer to the company's price lists and their relative updatings.